

CHRYSLER CORP.

ALL MODELS W/LEAF SPRINGS

CAMBER

No adjustment is provided for camber. Camber is preset at factory, and if not within limits, axle or steering knuckle is bent and should be replaced.

CASTER

Caster should be checked after camber and steering axis inclination have been checked. Caster adjustment is accomplished by inserting wedge between spring and axle. To increase caster, insert wedge with thick portion toward rear of vehicle. To decrease caster, insert wedge with thick portion of wedge toward front of vehicle.

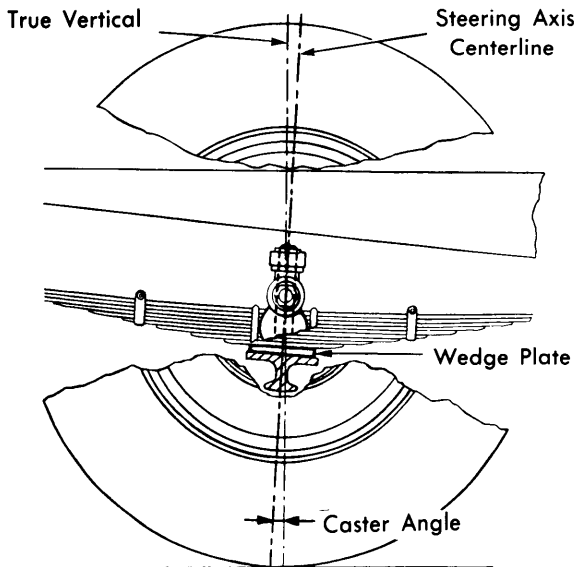

Fig. 1 Caster Angle Adjustment

ALL MODELS W/COIL SPRINGS

CASTER

Caster is controlled by eccentric bolts which mount upper control arm-to-frame. To obtain positive caster, loosen forward eccentric bolt lock nut and turn eccentric bolt to force front part of control arm outward, or loosen rear eccentric bolt lock nut and turn eccentric to pull rear of control arm inward. To obtain negative caster, loosen eccentric bolt lock nut and turn forward eccentric bolt to pull front part of control arm inward, or loosen rear eccentric bolt lock nut and turn eccentric bolt to force rear of control arm outward. Tighten eccentric bolt lock nuts to 70 ft. lbs.

CAMBER

Camber is controlled by eccentric bolts which mount upper control arm-to-frame. To increase camber, loosen eccentric bolt lock nuts and turn both eccentric bolts an equal amount to force upper control arm outward. To decrease camber, turn both bolts an equal amount to pull upper control arm inward. *NOTE* — Turning both bolts an equal amount will change camber without affecting caster. Tighten eccentric bolt lock nuts to 70 ft. lbs.

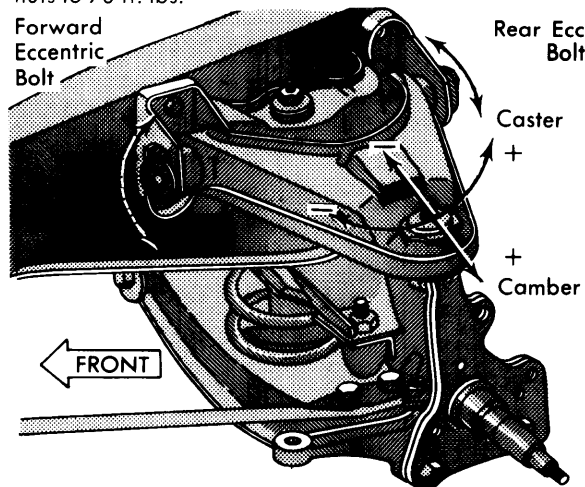

Fig. 2 Wheel Alignment Adjustments

FORD MOTOR CO.

RIDING HEIGHT

With vehicle on level surface, fuel tank full, and no other load, bounce both front and rear until suspension settles. Measure clearance between top of axle and frame side rail directly above axle. If clearance is not correct, insert spacer block between axle and frame to obtain correct riding height for purpose of checking and adjusting caster and camber.

CASTER

F250 4x4 — Caster adjustment is accomplished by inserting wedge between spring and axle. To increase caster, insert wedge with thick portion toward rear of vehicle. To decrease caster, insert wedge with thick portion toward front of vehicle.

All Other Models — Caster is preset at factory and no adjustment is provided. If not within limits, replace parts as necessary to correct.

CAMBER

All Models — Camber is preset at factory, and no adjustment is provided. If not within limits, replace parts as necessary to correct.

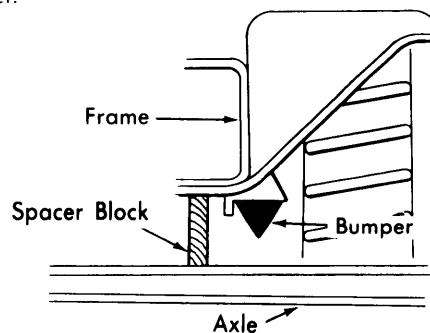

Fig. 1 Setting Riding Height