

# Brake Systems

## JEEP FLOATING CALIPER DISCS

Wagoneer  
Cherokee  
J-Series

### DESCRIPTION

Floating caliper disc brake assembly uses a single piston caliper which "floats" on two pins. As brake pedal is depressed, hydraulic pressure is passed through a proportioning valve to brake caliper piston. This force is transmitted to inboard brake pad and against braking surface of rotor or disc. Pressure then moves outer caliper housing and pad inward on caliper mounting pins, thus forcing outer pad against outer braking surface of rotor. When brake is released, pressure is removed from cylinders and inherent rotor runout moves pistons back into cylinders to maintain sufficient rotor-to-pad clearance.

### ADJUSTMENT & SERVICING

#### DISC PAD ADJUSTMENT

Automatic adjustment is provided by outward relocation of piston as lining wears.

#### BLEEDING SYSTEM

See *Hydraulic Brake Bleeding in this Section.*

### REMOVAL & INSTALLATION

#### BRAKE PADS

**Removal** — 1) Drain 2/3 of brake fluid from front reservoir using bleeder screw at front outlet port. Raise and support vehicle and remove front wheels. Place "C" clamp on caliper.

Solid end of clamp should contact back of caliper, and screw end should contact metal part of outboard shoes. Tighten clamp until caliper moves far enough to force piston to bottom of bore. This will back shoes off rotor surface, easing lining removal and installation.

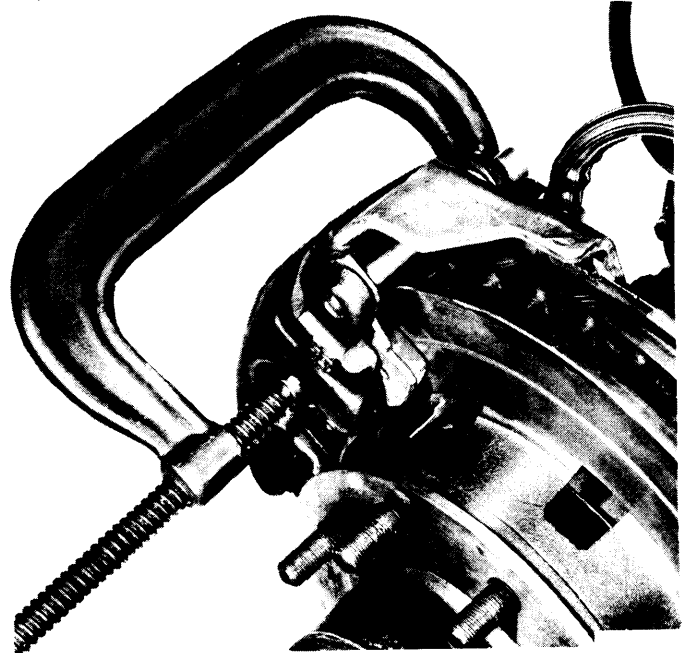

Fig. 1 Using a "C" Clamp to Bottom Caliper Piston

2) Remove both Allen head mounting bolts and lift caliper off rotor. Rest caliper on front spring or other suitable support. Do not allow brake hose to support weight of caliper. Remove both shoe and lining assemblies (pads). Remove support spring

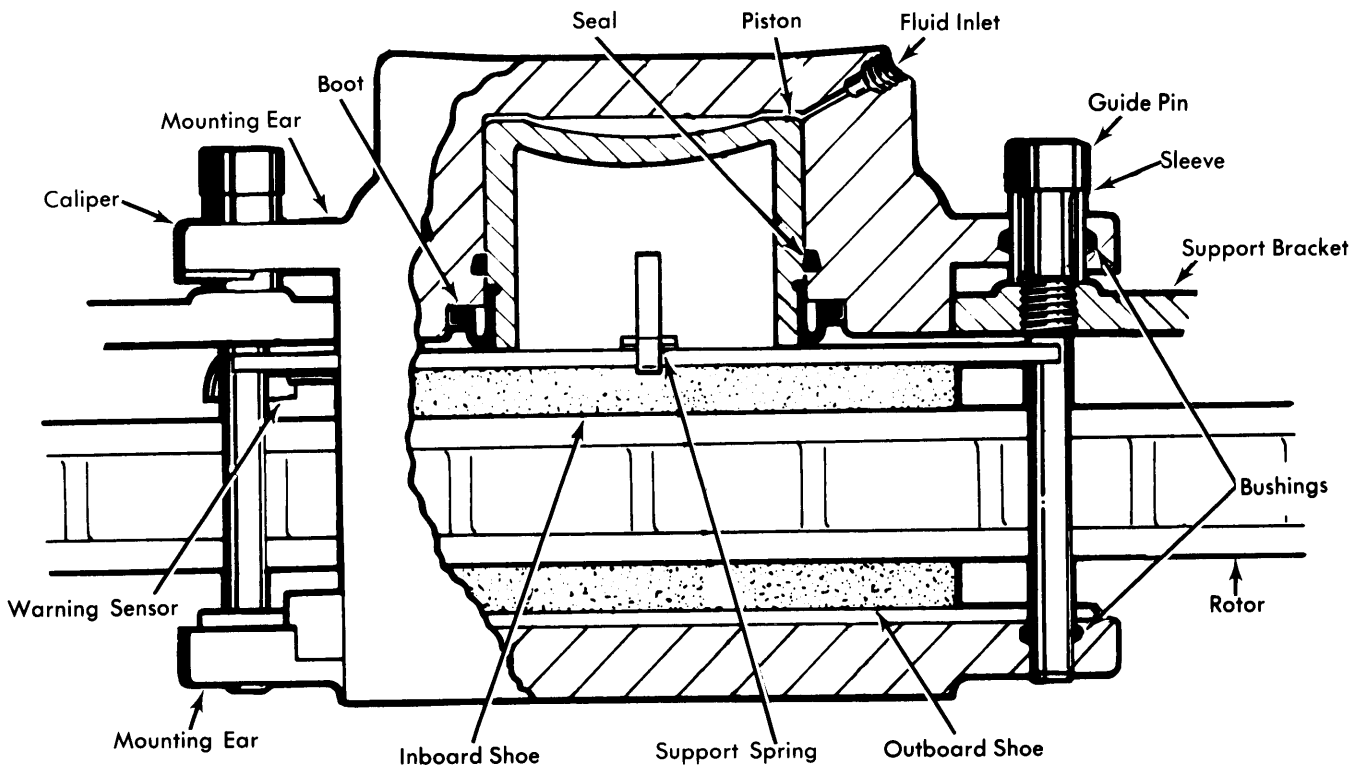

Fig. 2 Cutaway View of Floating Caliper Assembly

## JEEP FLOATING CALIPER DISCS (Cont.)

from inboard shoe and note spring position for correct installation later. Remove sleeves from inboard ears of caliper. Remove rubber bushings from all holes in caliper ears.

**Installation** — To install, reverse removal procedure noting the following: Lubricate new bushings, sleeves, bushing grooves, and small ends of mounting bolts with a silicone lubricant. Install rubber bushings in all caliper mounting ears. Use pliers to bend upper ears of outboard shoe until radial clearance between shoe and caliper is eliminated. Refill master cylinder.

### BRAKE CALIPER

See preceding Brake Pad procedure. To remove caliper completely from vehicle, disconnect brake line at caliper and tape hole to prevent contamination.

### OVERHAUL

**Disassembly** — 1) Remove caliper from vehicle and remove pads. If pads are to be reused, mark location in caliper. Clean caliper exterior with clean brake fluid. Drain residual fluid from caliper and place it on a clean working surface. Remove piston from caliper by applying compressed air to fluid port. **CAUTION** — Use just enough pressure to ease piston out of bore. Protect piston from damage with folded cloths, do not try to catch piston with fingers, serious injury could result.

2) Pry dust boot out of bore with screwdriver. Do not scratch bore. Using a small plastic or wooden stick, pry piston seal from bore. Remove bleeder screw, sleeves and rubber bushings. Clean all parts in clean brake fluid. Blow parts dry with dry, filtered compressed air. **NOTE** — Do not clean bolts with abrasive; protective plating may be removed.

3) Examine parts for rust, corrosion, pitting, scratches, or cracks. Do not attempt to refinish piston in any way. Removal of nickel-chrome plating will lead to pitting, rusting, and eventual cocking in bore. Minor stains on piston bore can be polished with crocus cloth only. Do not use emery cloth or any other abrasive. Wash bore thoroughly with brake fluid after using crocus cloth.

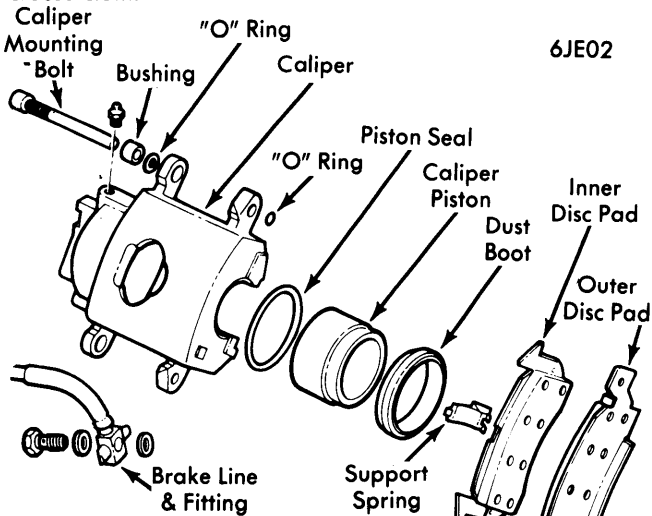

Fig. 3 Exploded View of Disc Brake Caliper Assembly

**Reassembly** — 1) Lubricate bore and new seal with brake fluid and install seal in groove. Lubricate piston with brake fluid and install new dust boot on piston. Assemble dust boot into piston groove so that fold in boot faces open end of piston. Slide metal retainer portion of dust boot over open end of piston and push retainer toward back of piston until lip on fold seats in piston groove. Then push retainer portion of boot forward until boot is flush with rim at open end of piston and snaps into place.

2) Insert piston in bore being careful not to unseat piston seal. Push piston to bottom of bore (requires 50-100 lbs. pressure). Position dust boot retainer in counterbore at top of piston bore. Seat dust boot retainer with suitable tool (J-22904). **NOTE** — Metal retainer portion of boot must be evenly seated in counterbore and fit below face of caliper. Install bleeder screw. Connect brake line to caliper using new copper gaskets. Install pads as outlined in Pad Removal and Installation. Install caliper over rotor, bleed brakes, and install wheel. Test system before moving vehicle.

### ROTOR

**Runout & Parallelism** — 1) Surfaces must be parallel within specifications. Surfaces not parallel will cause pads to wear at an angle. Runout must not exceed specified amount with rate of change not to exceed .001" in 30° of rotation.

2) Other measurements to be checked are: Hub-to-Rotor Squareness which is measured from center line of bearing cups to rotor. Surface Flatness or Taper which is the difference in thickness between outer and inner edge of rotor. Thickness Variation which is variation in thickness on any single radius.

### BRAKE SPECIFICATIONS

Application	Dimension
<b>Rotor Diameter</b>	
All (Exc. J-20).....	12.0"
J-20.....	12.5"
<b>Rotor Thickness</b>	
New.....	①
Minimum.....	1.125"
<b>Parallelism</b> .....	.003"
<b>Runout</b> .....	.005"
<b>Hub-To-Rotor Squareness</b> .....	.003"
<b>Surface Flatness</b> .....	.003"
<b>Thickness Variation</b> .....	.0005"
<b>Pad Thickness</b>	
New.....	①
Minimum.....	②

① — Specification not available.

② — Specification not available. A wear sensor is fitted on pads which makes noise when pad wear allows it to come in contact with rotor.

### TIGHTENING SPECIFICATIONS

Application	Ft. Lbs.
<b>Bleeder Screw</b> .....	40-140 INCH Lbs.
<b>Guide Pins</b> .....	35
<b>Brake Line-to-Caliper</b> .....	160 INCH Lbs.