

## FORD MOTOR CO. DUAL CYLINDER DUO-SERVO

M-450 & M-500 (MHC)

### DESCRIPTION

Dual cylinder, dual piston brake system consists of two shoes, backing plate, retracting springs, automatic adjuster components and two wheel cylinders. The two automatic adjusters used on each brake assembly consist of adjuster block, shoe adjusting lever, adjusting link, star wheel adjuster and anchor spring. Adjusters use movement of shoes during reverse brake application to turn brake adjusting screw and maintain proper lining to drum clearance.

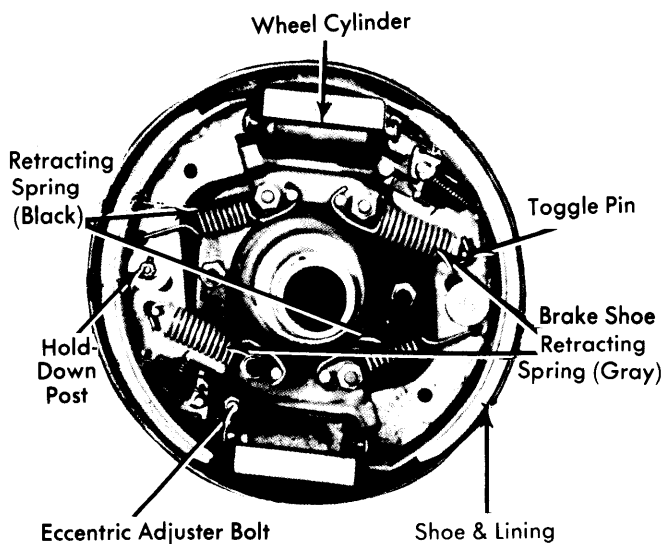

Fig. 1 Dual Cylinder Duo-Servo Brake Assembly

### ADJUSTMENT & SERVICING

#### BRAKE SHOE ADJUSTMENT

With brake drums at room temperature, rotate drum forward and check drag. Remove adjusting slot covers in backing plate. Turn rear (secondary shoe) until shoe drags slightly with drum. Repeat same procedure for front (primary shoe). Install slot covers. Back up vehicle and apply brakes several times to complete adjustment. Check brake operation.

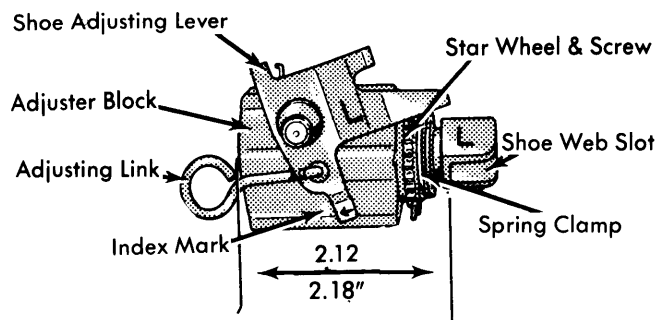

Fig. 2 Automatic Adjuster Component Identification

#### PARKING BRAKE ADJUSTMENT

Release parking brake lever. From under vehicle, remove cotter pin from adjusting clevis pin and remove pin. Lengthen adjusting link by turning clevis. Continue to lengthen until shoes seat against drum when clevis pin is installed. Remove clevis pin and shorten linkage until there is a slight clearance between shoes and drum. Install clevis pin and new cotter pin.

#### BLEEDING SYSTEM

See *Hydraulic Brake Bleeding in this Section*.

### REMOVAL & INSTALLATION

#### BRAKE SHOES

**Removal** — Raise vehicle and remove wheel and tire, and drum. Clamp brake cylinder boots against ends of cylinders using suitable brake cylinder clamps. **NOTE** — Note position of two different types of retracting spring. Remove retracting springs. Remove brake shoe hold-down post cotter pin, nut and washer. Loosen and remove eccentric adjuster bolt, lock washer, eccentric and adjusting link. Remove brake shoes. Remove anchor block spring and slide adjuster assembly off web of brake shoe. Remove star wheel and screw from adjuster block.

**Installation** — 1) Lubricate all contact points of brake shoes, adjuster screw and inside of adjuster block. Thread adjuster screw into star wheel and insert adjuster screw in block. Turn screw until a distance of 2.12-2.18" from end of adjuster block to screw web slot is obtained. Install adjuster assembly on shoe web and attach anchor block spring. Position brake shoe over retracting spring toggle pin and insert ends of shoe in wheel cylinder links. Install shoe and hold-down washer and nut, but do not install cotter pin.

2) Install brake shoe retracting springs. On models with 4" wide brakes, install retracting springs so that inner hook ends face axle. On 5" wide brake models, inner hook ends face wheel cylinders. Install cylinder link, eccentric, lock washer and bolt but do not tighten bolt. Remove brake piston clamps. Tighten shoe hold-down nut until .015-.025" clearance between the shoe and hold-down washer is obtained. Install cotter pin. With shoes centered on locking plate, rotate eccentric until adjusting lever is at index mark. Tighten eccentric adjuster bolt. Install drum, wheel and tire, and adjust brakes.

### OVERHAUL

#### WHEEL CYLINDER

**Removal** — Remove wheel, drum and brake shoes. Remove cylinder links and disconnect brake lines from brake cylinders. Remove retaining bolts and remove cylinder.

**Installation** — Place cylinder on backing plate, install and tighten bolts. Install new gasket on brake line fitting (if equipped) and connect line to cylinder. Install remaining components to complete installation. Adjust and bleed brakes.

#### WHEEL CYLINDER

**Disassembly** — With wheel cylinder removed, remove rubber boots from end of cylinder. Remove pistons, cups and spring.

**Assembly** — Inspect bore of cylinder for scoring or pitting and replace as necessary. Coat all components with **brake fluid** and reverse disassembly procedure to assemble.