

# Master Cylinders

## BENDIX MINI-MASTER CYLINDER

Chevrolet  
GMC

*NOTE — The Bendix Mini-Master Cylinder is used on all "G" and "P" models equipped with Hydroboost.*

### DESCRIPTION

Functions of the Bendix Mini-Master cylinder are basically the same as a conventional master cylinder although components differ. When master cylinder is in released position, primary and secondary actuators are in contact with compensating valve stems which project into cylinder bore. This keeps valves off their seat and opens communication between cylinder bore and reservoir. The initial forward movement of piston permits compensating valves to seat, this closes communication between pressure chambers in cylinder bore and reservoir. As piston travels further, pressure build up is transmitted to calipers and wheel cylinders. On Motor Home Chassis models with four-wheel disc brakes, the brake warning light switch is an integral part of the master cylinder and is non-serviceable. The brake distribution block is not a combination valve, it acts only as a fluid distributor.

### ADJUSTMENT

#### BRAKE PEDAL

See *Bendix Hydroboost* article in this Section.

#### BRAKE WARNING SWITCH

**All (Exc. Motor Home Chassis)** — If pressure loss occurs in one side of system, piston in valve will move toward failed side and latch in that position. This will cause brake system warning light to come on and stay on until brake system is repaired. After repairing and bleeding system, applying brakes with moderate force will hydraulically recenter piston and turn off light.

**Motor Home Chassis** — Brake warning light switch is integral in master cylinder and is non-serviceable.

### REMOVAL & INSTALLATION

**Removal** — Depress and release brake pedal several times with engine not running. This will make sure that all pressure is discharged from accumulator. It will be necessary to raise motor home chassis models to gain access to master cylinder. On all models, clean dirt and grease from hydraulic brake line connections. Disconnect brake lines from master cylinder. Remove nuts and washers that secure master cylinder to Hydroboost. Remove master cylinder. Cover ends of brake lines.

**Installation** — To install, reverse removal procedure. Bleed brake hydraulic system. See *Hydraulic Brake Bleeding* in this Section.

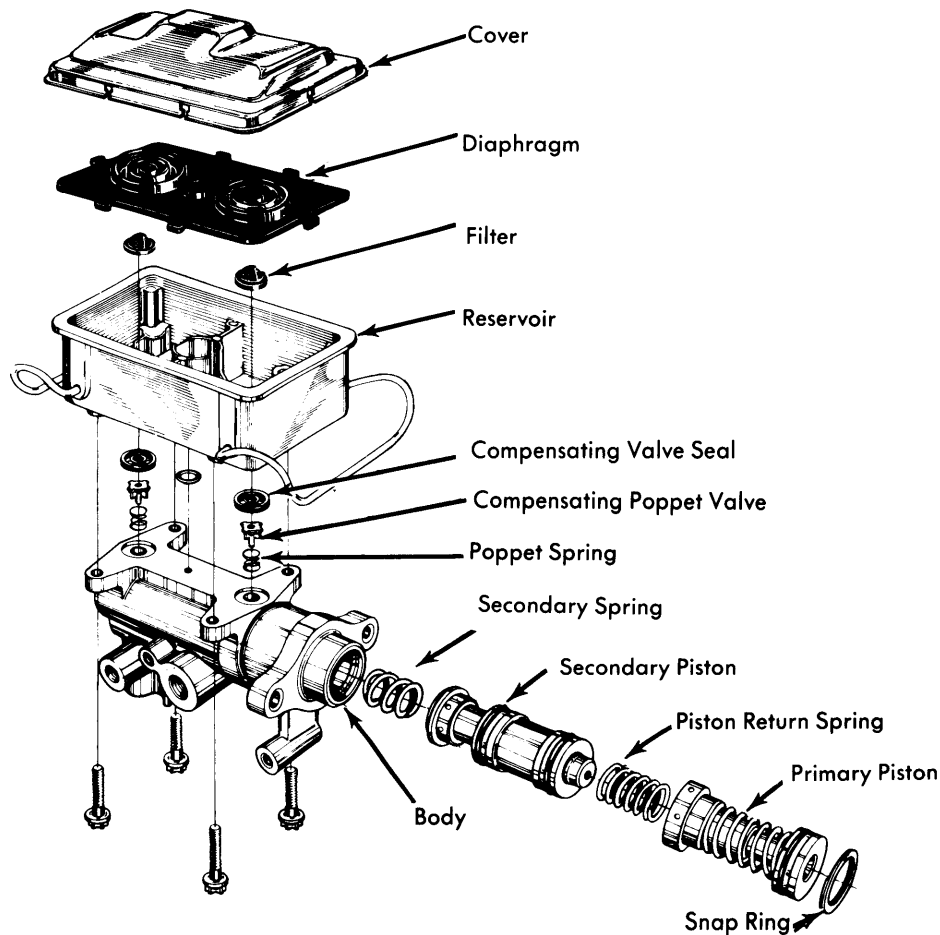

Fig. 1 Exploded View of Bendix Mini-Master Cylinder Assembly

## BENDIX MINI-MASTER CYLINDER (Cont.)

### OVERHAUL

#### MASTER CYLINDER

**Disassembly – 1)** Remove reservoir cover and diaphragm. Drain all brake fluid. Remove four reservoir bolts and separate reservoir and master cylinder body. Remove small "O" ring and both compensating valve seals from bottom of reservoir. **NOTE – Do Not remove two filters from bottom of reservoir unless they are damaged.** Push in primary piston and remove compensating valve poppets and springs from ports in master cylinder body.

**2)** Remove snap ring from master cylinder bore using a small screwdriver. Release primary and secondary pistons and remove from bore. It may be necessary to plug front outlet port and apply low air pressure to front compensating valve port to remove secondary piston assembly. **CAUTION – If air pressure is used to remove piston, place open end of bore 1" away from padded surface to catch piston and prevent personal injury.**

**Cleaning & Inspection –** Clean all reusable components in clean brake fluid. Make sure filters in bottom of reservoir are clean. If filters do not clean thoroughly, they must be replaced. After cleaning, inspect all components for wear or damage and replace as necessary.

**Reassembly – 1)** Lubricate primary and secondary pistons, and cylinder bore with clean brake fluid. Position secondary spring (short spring) in open end of secondary piston actuator. Position return spring (long spring) on projection at rear of secondary piston. Place secondary piston, actuator end first in master cylinder bore and press assembly into bottom of bore. Insert primary piston, actuator end first into bore.

**2)** Using a smooth round end tool with snap ring placed over it, depress piston in bore. Install snap ring in groove. Place compensating valve seals and small "O" ring seal in recesses in bottom of reservoir. Make sure seals are fully seated. Depress pistons and place compensating valve springs and poppets in valve ports. With piston still depressed, place reservoir in position. Install bolts and tighten to 12 to 15 ft. lbs.