

Master Cylinders

FORD MOTOR CO. DUAL PISTON MASTER CYLINDER

All Models

DESCRIPTION

Ford tandem dual piston master cylinder is a single casting with front and rear piston and a separate reservoir and outlet for each piston. Rear piston is operated by a push rod connected to brake pedal. Front, or floating, piston is operated by rear piston. In a combination drum and disc system, reservoir which feeds disc brakes is larger, to correspond with large size of disc brake caliper cylinders. Master cylinder outlet which feeds drum brake has a residual valve under tube seat. Disc brake outlet has no valve, since disc brakes must not have any residual pressure. **NOTE** — Master cylinder used with 4-wheel drum brakes has residual pressure valves and springs in both brake line outlets. Failure in either front or rear system does not result in failure of entire system.

ADJUSTMENT

BRAKE PEDAL

On dual piston master cylinder or brake mounted vacuum booster equipped vehicles, brake systems are designed to permit full stroke of master cylinder, therefore no brake pedal clearance adjustment is required.

PRESSURE DIFFERENTIAL VALVE

With ignition switch in "ON" or "ACC" position, slowly depress and release brake pedal until pressure differential valve is centered and warning light goes off. Bring fluid level in master cylinder to within $\frac{1}{4}$ " of top and turn ignition switch to "OFF" position.

REMOVAL & INSTALLATION

MASTER CYLINDER

Removal — All Power Brake Models — Depress brake pedal to dispell vacuum from brake booster. Disconnect all hydraulic lines at master cylinder. Remove nuts retaining master cylinder to brake booster and remove master cylinder.

Removal — All Non-Power Brake Models — Disconnect wires from stoplight switch. Remove dust boot from rear of master cylinder at dash panel. Disconnect master cylinder push rod from brake pedal. Remove stoplight switch from brake pedal assembly. Separate push rod from brake pedal and remove dust boot. Disconnect all hydraulic lines at master cylinder. Remove bolts securing master cylinder to dash panel and remove master cylinder.

Installation — All Models — **NOTE** — On vehicle equipped with power booster, adjust push rod length prior to installation of master cylinder (See appropriate article in this

Section). To install, reverse removal procedure, centralize pressure differential valve, and bleed system. See *Hydraulic Brake Bleeding* in this Section.

PRESSURE DIFFERENTIAL VALVE

Removal — Raise vehicle off ground and disconnect brake warning light wire at valve assembly switch. Remove hydraulic brake lines at differential valve. Remove bolt retaining valve to frame side rail, and remove valve. If either switch or valve are to be replaced, remove switch from valve, as they are serviced as separate units.

Installation — To install, reverse removal procedure and bleed brake system. See *Hydraulic Brake Bleeding* in this Section. Check operation of warning switch, and if necessary, centralize switch. See *Pressure Differential Valve Adjustment*.

OVERHAUL

MASTER CYLINDER

Disassembly — 1) With master cylinder removed from vehicle, clean outside of cylinder, remove filler cap and diaphragm, and drain any fluid still in cylinder. Remove piston stop from cylinder, and remove "O" ring seal from stop.

2) Remove dust boot, then remove snap ring retaining piston assemblies. Remove push rod (if so equipped) and primary piston assembly from cylinder bore. Apply air pressure to forward outlet port of cylinder and carefully blow secondary piston assembly out of bore. Remove return spring, spring retainer, cup protector, and cups from secondary piston.

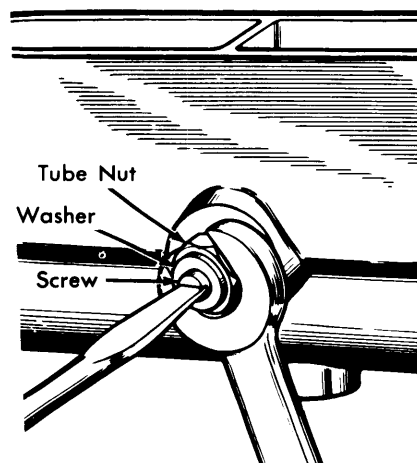

Fig. 1 Removing Tube Seat from Master Cylinder

NOTE — Following procedure applies to P-350 models only.

3) Place master cylinder in a vise with outlet ports facing up, using care not to damage housing. Install spare brake line tube nut in brake outlet port supplying drum brakes. Position flat washer over self-tapping 8-32 screw and thread screw into outlet port through brake line nut. While holding screw to prevent its turning, turn tube nut out of port. This procedure will remove tubing seat. Remove master cylinder from vise and remove residual valve(s).

Inspection — Clean all parts with denatured alcohol, and blow dry with compressed air. Inspect all parts for chipping, excessive wear, or damage. Check all recesses, openings, and internal passages to be sure they are clean and open. **Inspect**

FORD MOTOR CO. DUAL PISTON MASTER CYLINDER (Cont.)

master cylinder bore for signs of corrosion, pitting, etching, or scoring. If any of these conditions exist, manufacturer recommends replacement of master cylinder assembly.

NOTE — Step 1 in reassembly applies to P-350 models only.

Reassembly — 1) Position master cylinder in a vise with outlet ports facing up. Insert check valve spring in residual check valve, and position assembly in outlet port. **CAUTION — Install residual check valve(s) in only those outlets which feed drum brakes. Be sure spring is properly seated in bottom of port.** Place new brass tubing seat(s) into port(s) and thread spare brake line tubing nut into port until seat is bottomed in port. Remove nut.

2) Remove cylinder from vise, and clean housing. Dip all parts, except cylinder housing, in clean brake fluid prior to final assembly. Install two secondary cups, back-to-back, on secondary piston, then assemble cup protector, primary cup, spring retainer, and secondary piston return spring on opposite end of piston. Insert secondary piston assembly into bore in cylinder.

3) Install new "O" ring on piston stop, and start stop into cylinder body. On vehicles equipped with standard brakes,

position boot, snap ring, and push rod retainer on push rod, and seat assembly in primary piston. Install primary piston in cylinder bore, tighten secondary piston stop screw and install snap ring in end of cylinder bore.

4) On vehicles equipped with power assisted brakes, position stop plate and snap ring on primary piston, and install assembly in bore of master cylinder.

5) Before installing master cylinder assembly on vehicle, bleed as follows: Support master cylinder in a vise and fill both fluid reservoirs. Loosely install plugs in both outlet ports, then depress primary piston several times until air bubbles cease to appear in fluid reservoirs. Tighten plugs and attempt to depress piston. Piston travel will be greatly restricted when all air is expelled. Remove plugs, install cover and diaphragm, and remove assembly from vise.

PRESSURE DIFFERENTIAL VALVE

Pressure Differential Valve should be replaced if found to be defective. Differential valve and brake warning lamp switch are separate units and each is serviced as a separate assembly only.

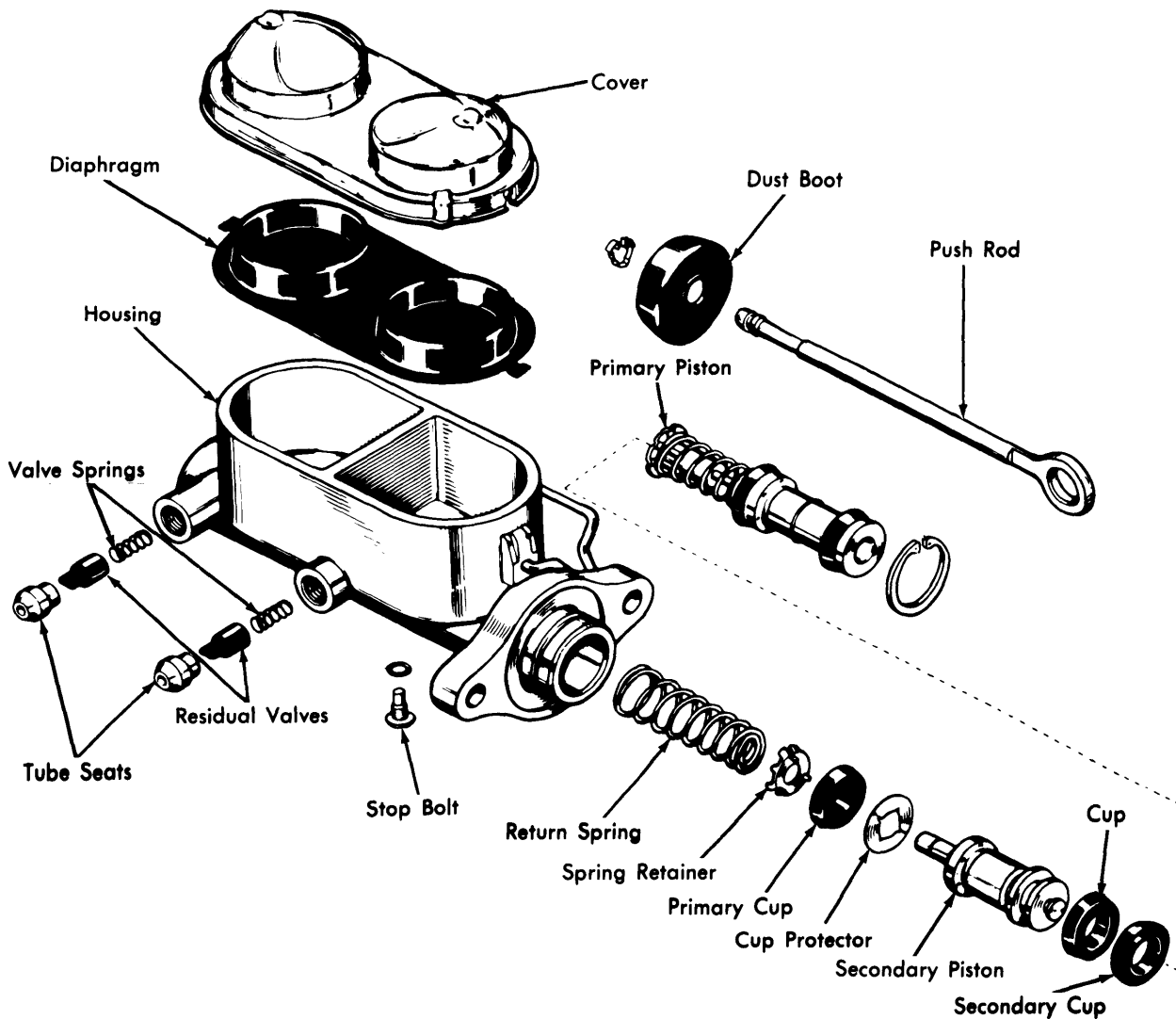

Fig. 2 Exploded View of P-350 Master Cylinder Assembly

Master Cylinders

FORD MOTOR CO. DUAL PISTON MASTER CYLINDER (Cont.)

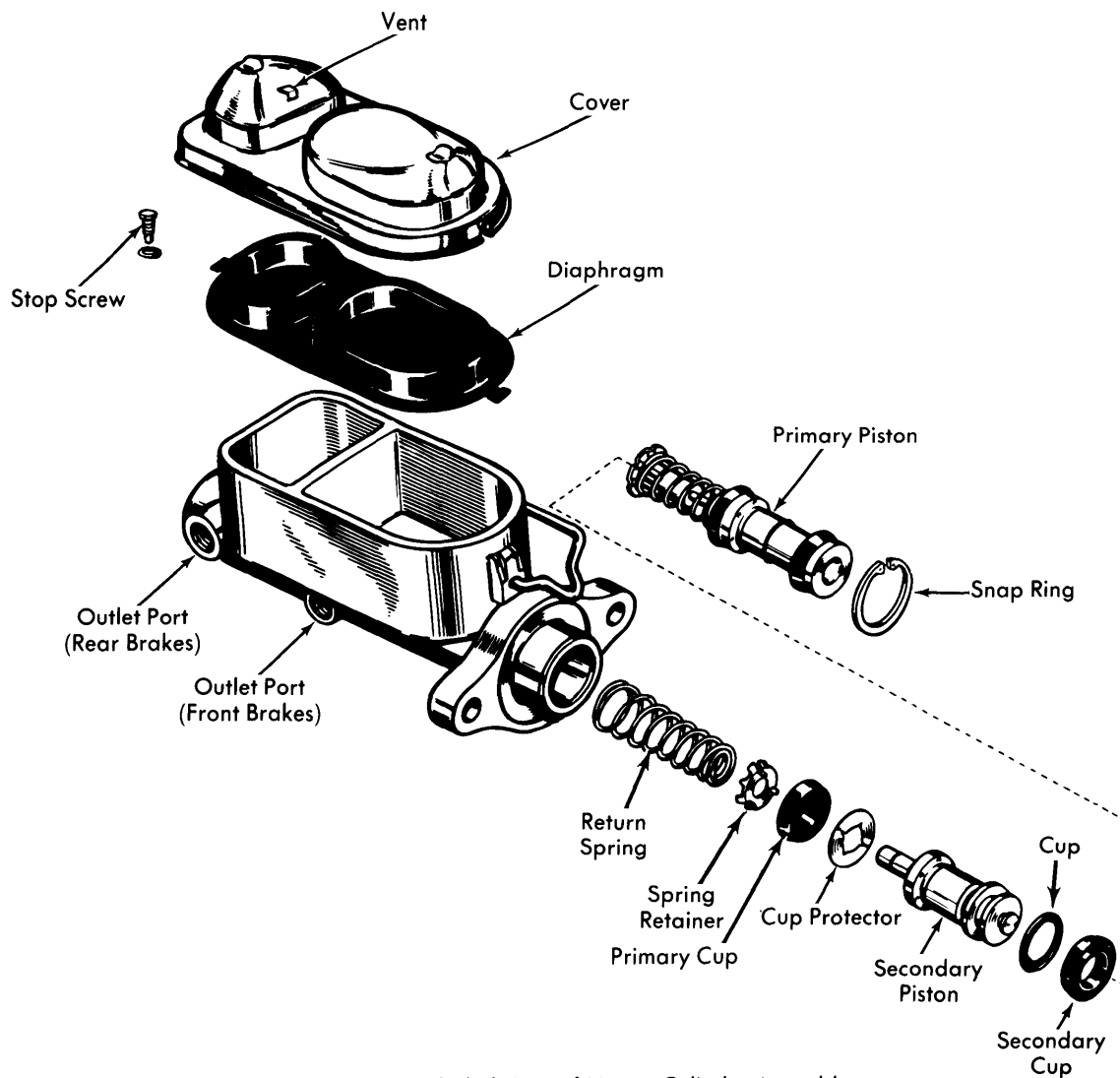

Fig. 3 Exploded View of Master Cylinder Assembly
(All Models Except P-350)