

## GENERAL MOTORS

Chevrolet  
GMC  
GMC Motor Home

smooth, ball studs may turn in joint when nuts are tightened. Sleeve clamps must always be positioned as specified before tightening bolts.

**Steering System Service Precautions** — All steering component fasteners are made of special quality materials. Replacement fasteners must be of same part number or equivalent. Torque all fasteners to specification and install new cotter pins. When installing cotter pins, do not back off castellated nuts to align cotter pin hole, tighten nut to next slot that lines up with hole. Do not hammer on ball studs or damage to threads may result. If threads are not clean and

### ALL MODELS

**Tie Rod Removal** — 1) Raise vehicle and remove tie rod fasteners. Remove outer ball stud by tapping on steering arm at tie rod end with a light hammer while using a heavy hammer as a backing. Remove inner ball stud from relay rod using same procedure.

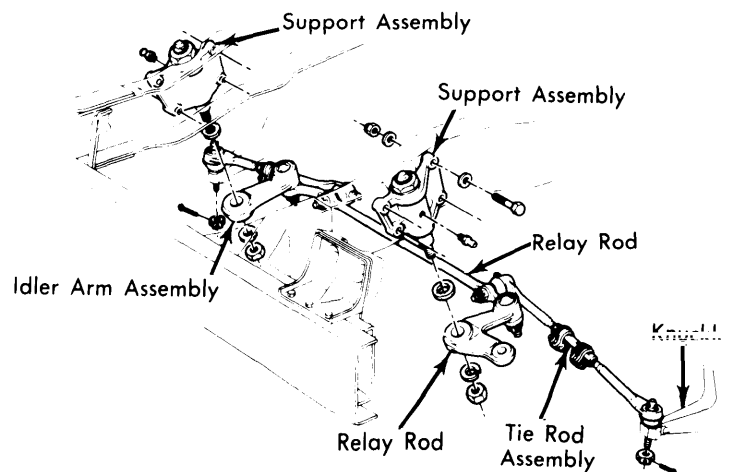
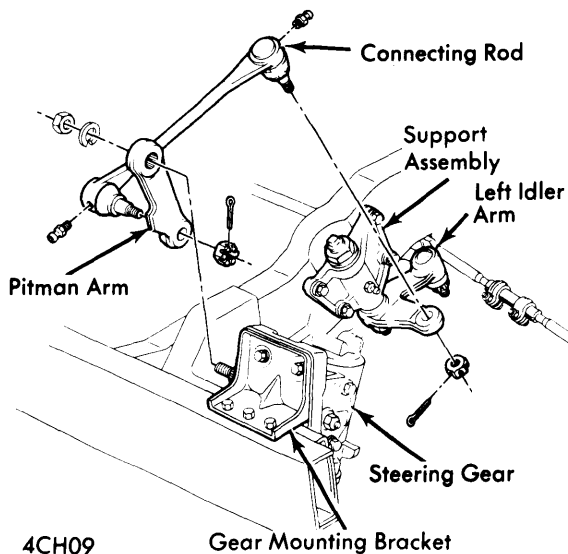
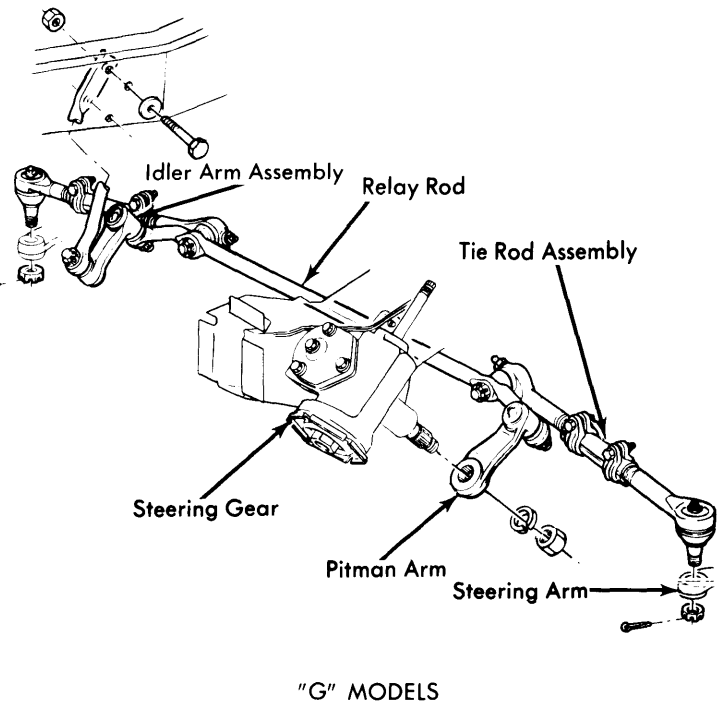
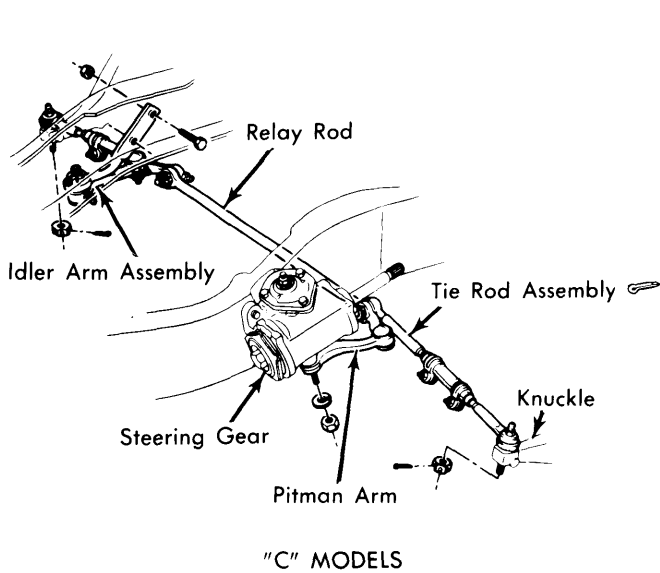

MOTOR HOME

### STEERING LINKAGE

# Steering Linkage

## GENERAL MOTORS (Cont.)

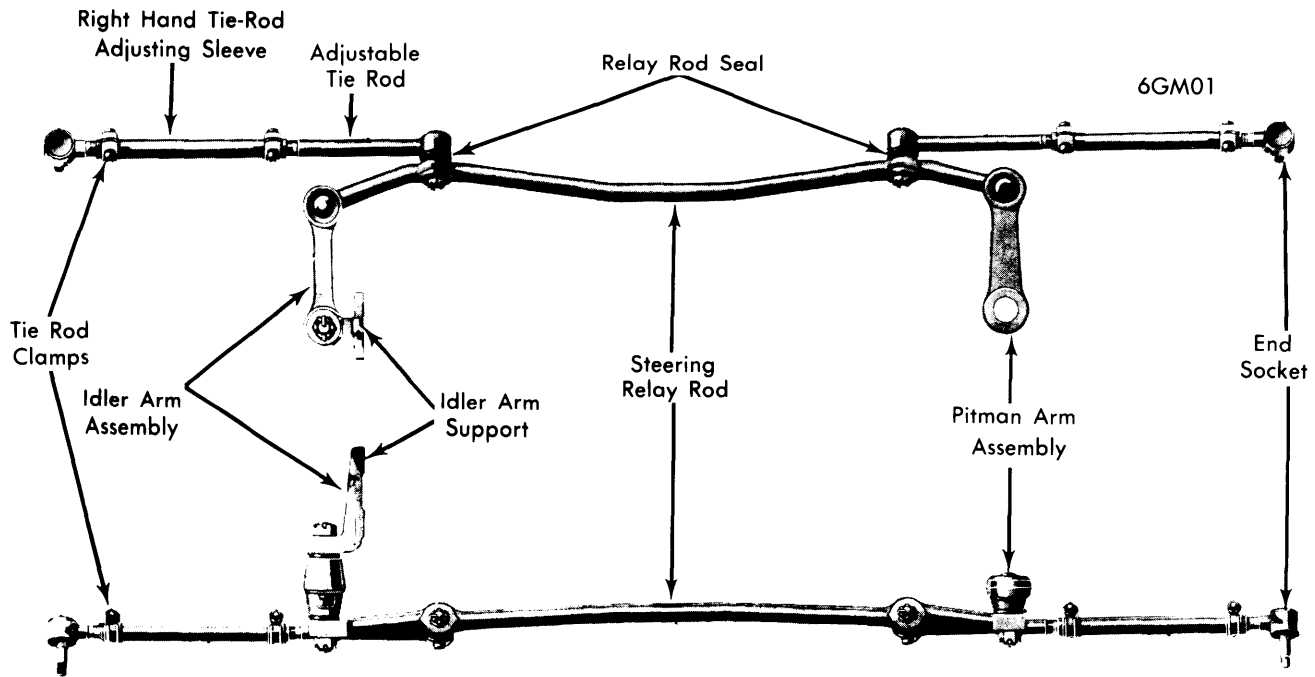

**STEERING LINKAGE COMPONENTS, ALL MODELS WITH INDEPENDENT FRONT SUSPENSION**

2) To remove tie rod ends from tie rod, loosen clamp bolts and unscrew end assemblies. Tie rod adjuster clamp bolts often become rusted in service. It is recommended that if torque required to remove the nut from a bolt after breakaway exceeds 7 ft. lbs., discard the nuts and bolts. Apply penetrating oil between clamps and tube, and rotate clamps until they move freely. Use new fasteners of same part number during reassembly to assure proper clamping at specified nut torque.

3) To install tie rods, use following procedure: Lubricate tie rod threads with EP chassis lube and install tie rod ends making sure both are threaded an equal distance from tie rod. Check that threads on ball studs and nuts are clean and smooth. Check condition of ball stud seals and replace if necessary using suitable tool (J-24434). Install ball studs in steering arms and relay rod. Install ball stud nuts and torque to specifications, and install new cotter pins. Adjust toe-in. See *Wheel Alignment Specifications & Procedures* in **WHEEL ALIGNMENT** Section.

4) Before tightening tie rod adjusting sleeve clamp bolts, note following: Clamps must be positioned between locating dimples at either end of sleeve as shown in illustration. Slot in adjuster sleeve must be within open area of clamp jaws or not closer than .10" to edge of clamp jaw opening. Rotate both inner and outer tie rod housings rearward to limit of ball joint travel before tightening clamps. Tighten clamps to specifications and return tie rod assembly to center of travel. Check each tie rod for a rotation of at least 35° using a bubble protractor and a pair of vise grips. Lubricate inner and outer tie rod ends.

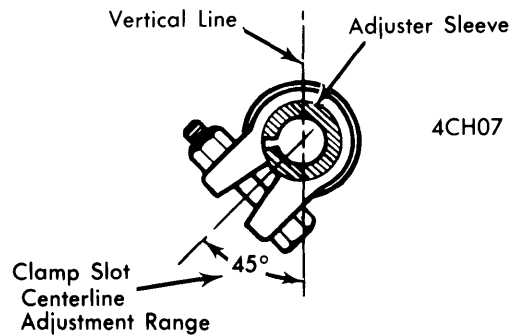

**TIE ROD CLAMP POSITIONING, "C", "K" & "P" MODELS**

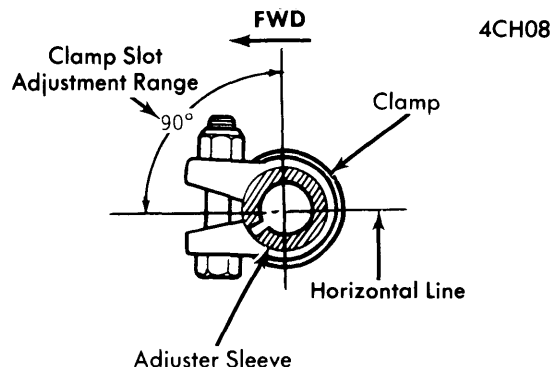

**TIE ROD CLAMP POSITIONING, "G" MODELS**

## GENERAL MOTORS (Cont.)

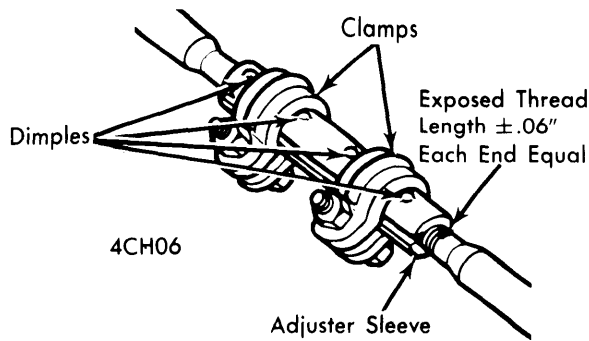

**TIE ROD CLAMPS BETWEEN DIMPLES (TYPICAL)**

**Idler Arm Removal** – 1) Place vehicle on a hoist. Remove fasteners from ball stud at relay rod. Remove ball stud from relay rod by tapping on relay rod boss with a hammer, while using another hammer as a backing. Remove idler arm-to-frame bolts and remove idler arm assembly. *NOTE* – *Idler arm assembly should always be replaced if it is found that an up and down force of 25 lbs., applied at relay rod end of idler arm, produces a vertical lash of more than 1/8" in straight ahead position.*

2) To install, reverse removal procedure and note following: Install idler arm-to-frame bolts using special plain washers under bolt heads, torque nuts to specifications. Check ball studs and nuts for clean and smooth threads. Check stud seals and replace if necessary. Install idler arm ball stud in relay rod and check position of seal. Torque nuts and install cotter pins.

### ALL MODELS

**Relay Rod Removal** – 1) Remove inner ends of tie rods from relay rod (on models where applicable). Remove relay rod ball stud cotter pins and castellated nuts. Remove relay rod from pitman and idler arms by tapping on relay rod ball stud bosses with a hammer, while using another hammer as a backing.

2) To install, reverse removal procedure and note following: Check ball studs and nuts for clean and smooth threads. Check stud seals and replace if necessary. Torque nuts and install new cotter pins.

**Pitman Arm Removal** – 1) Raise vehicle on a hoist. Remove cotter pin from pitman arm ball stud and remove nut. Remove pitman arm or relay rod from ball stud by tapping on side of rod or arm (in which stud mounts) with a hammer while using another hammer as a back-up. Remove pitman arm nut from shaft or clamp bolt from pitman arm, and mark arm-to-shaft position. Remove pitman arm from shaft using suitable puller.

2) To install, reverse removal procedure and note following: If a clamp type pitman arm is used, spread pitman arm with a wedge just enough to slip arm onto shaft by hand pressure. Do not hammer or damage to steering gear may result. Be sure to reinstall the hardened steel washer before installing nut.

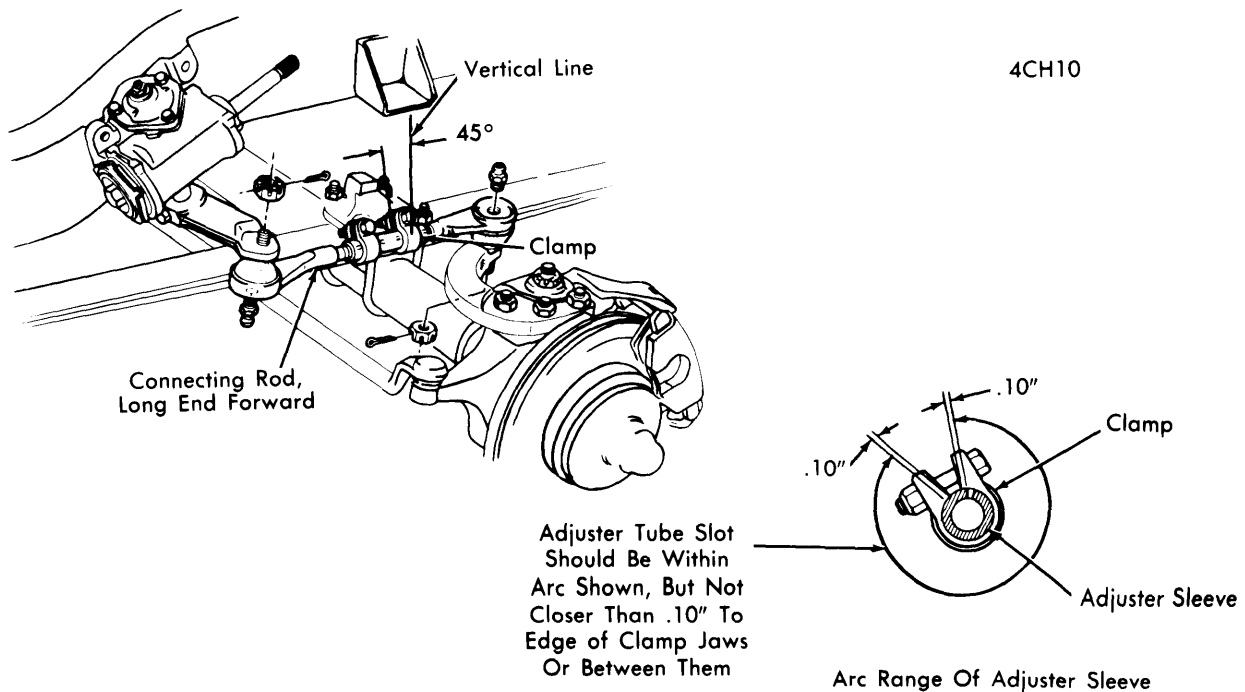

**ADJUSTABLE CONNECTING ROD ASSEMBLY, "K" MODELS**

# Steering Linkage

## GENERAL MOTORS (Cont.)

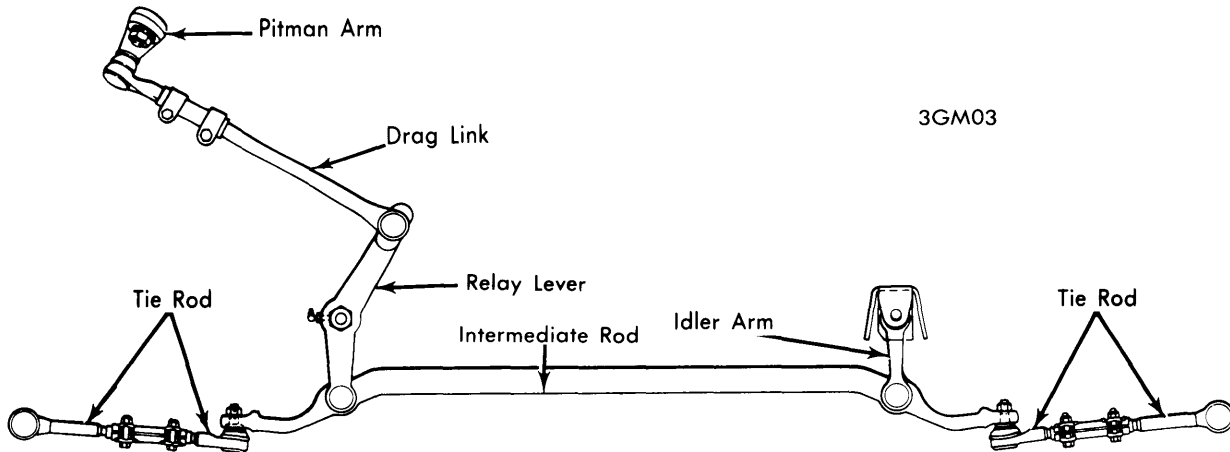

GMC MOTOR HOME STEERING LINKAGE

### "K" MODELS & MOTOR HOME

**Steering Connecting Rod** - 1) Remove cotter pins from ball studs and remove castellated nuts. Remove ball studs from steering arm and pitman arm boss with a heavy hammer and striking other side of boss with a lighter hammer.

2) To install, reverse removal procedure and note following: Ensure that threads on studs and nuts are clean and smooth. Check ball stud seals and replace if necessary. Install connecting rod on steering components, torque nuts and install new cotter pins. See illustration for proper alignment and orientation of connecting rod clamps.

TIGHTENING SPECIFICATIONS (GMC MOTOR HOME)	
Application	Ft. Lbs.
Steering Arm-To-Tie Rod End	40-50
Tie Rod Clamp Nuts	19-24
Tie Rod-To-Intermediate Rod	40-50
Idler Arm-To-Intermediate Rod	40-50
Idler Arm-To-Frame	85-110
Relay Lever-To-Intermediate Rod	40-60
Relay Lever-To-Frame	250-300
Drag Link-To-Relay Lever	40-60
Drag Link-To-Pitman Arm	40-60
Pitman Arm-To-Steering Gear	160-210

### TIGHTENING SPECIFICATIONS

Application	Ft. Lbs
Tie Rod Ball Stud Nuts	
C & G-10, P 10-30	①35
All Others	②45
Tie Rod Clamps	
K 10-30	35
All Others	22
Idler Arm Mounting Bolts	30
Idler Arm-To-Relay Rod Nut	
G 10-30	70
All Others	60
Pitman Arm-To-Relay Rod Nut	
G 10-30	70
All Others	60
Steering Connecting Rod Nut	
K 10-20	③50
Steering Connecting Rod Clamps	
K 10-20	40
Pitman Arm-To-Pitman Shaft Nut	
K 10-20	90
All Others (W/Power Steering)	180
All Others (W/Manual Steering)	140

- ① - Plus torque required to align cotter pin, max. 50 ft. lbs.
- ② - Plus torque required to align cotter pin, max. 60 ft. lbs.
- ③ - Plus next slot for cotter pin.