

Front Suspension

FORD MOTOR CO. 2-WD COIL SPRING TYPE

"F" Models
"E" Models

REMOVAL & INSTALLATION

DESCRIPTION

Front suspension consists of two "I-Beam" reverse Elliot type axles, mounted to a frame pivot bracket at one end, and to the steering knuckle and a radius arm at the other end. Steering knuckle is mounted to the axle by solid, constant diameter kingpin. Either Delrin or bronze bushings are pressed into steering knuckles to provide bearing surfaces for kingpin. Radius arm runs rearward from axle and is attached to a bracket, mounted to frame side rail, at the rear. Coil spring is seated on top of radius arm at bottom of spring, and in a bracket mounted to frame at the top. Hydraulic, double-action shock absorber is mounted between frame and radius arm to dampen road shock.

ADJUSTMENT

WHEEL ALIGNMENT SPECIFICATIONS & PROCEDURES

See *Wheel Alignment Specifications & Procedures* in *WHEEL ALIGNMENT* Section.

WHEEL BEARING ADJUSTMENT

See *Wheel Bearing Adjustment* in *WHEEL ALIGNMENT* Section.

STEERING KNUCKLE

Removal — Raise and support vehicle under front axle. Remove wheel, brake drum (or disc), and wheel bearings as an assembly. Remove brake backing plate, and support to prevent damage to brake hose. On vehicles with removable steering arm, remove steering arm from knuckle. On all others, disconnect steering linkage at steering knuckle. Remove kingpin locking pin, and remove upper and lower kingpin plugs and/or retainers. Drive kingpin out from top of axle, and remove steering knuckle from vehicle.

Installation — Before installing steering knuckle, pack thrust bearing with chassis lubricant, and position bearing with open end (lip side) down against steering knuckle. Install kingpin in axle and steering knuckle, making sure notch in kingpin is aligned with lock pin hole in steering knuckle. **NOTE** — *Install kingpin so that end with letter "T" stamped in end is up.* Install a new lock pin and tighten nut. Install upper and lower spindle plugs. To complete installation, reverse removal procedure.

KINGPIN BUSHINGS

Removal — **NOTE** — *Delrin bushings do not require special tools for removal or installation, and should not be reamed.* Remove steering knuckle from vehicle as previously described. Drive bushing out of bore in steering knuckle, using a tool slightly smaller in diameter than bore in steering

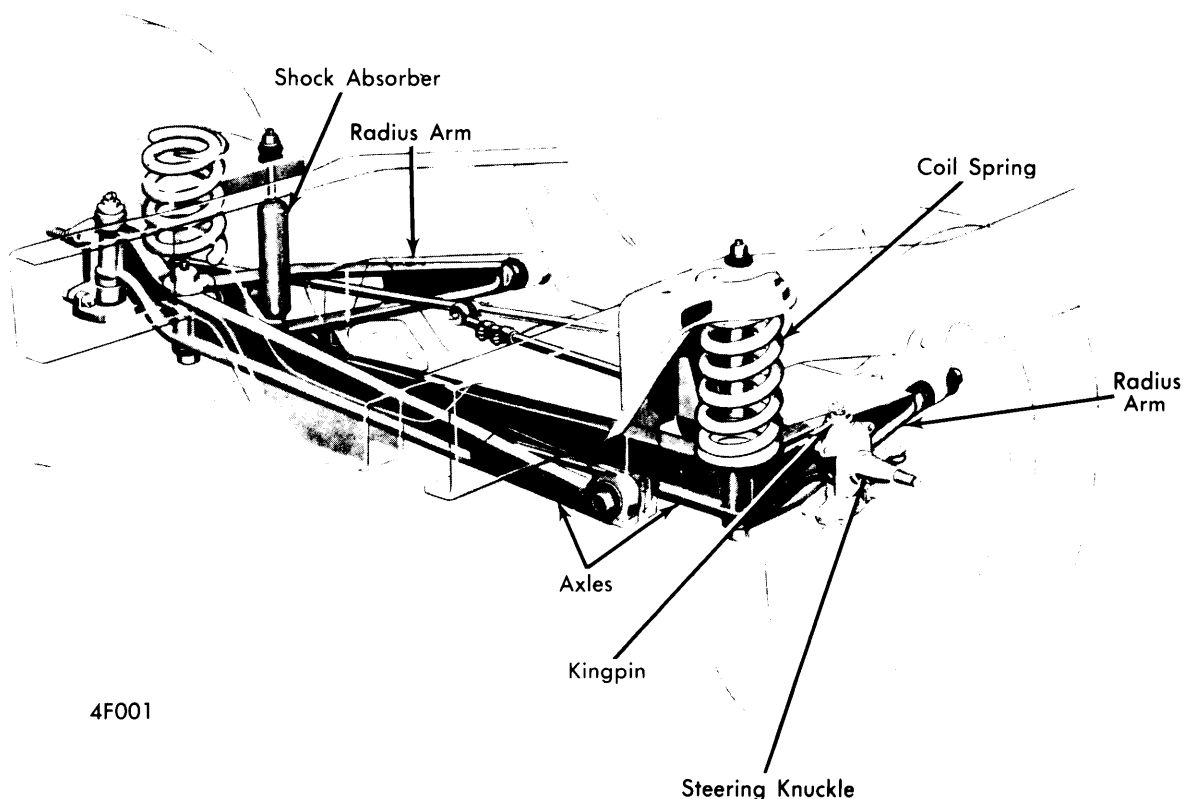

4F001

FRONT SUSPENSION ASSEMBLY

FORD MOTOR CO. 2-WD COIL SPRING TYPE (Cont.)

knuckle. Clean bores in steering knuckle, and make sure lubrication grooves in knuckle are not plugged.

Installation — Position bushing in steering knuckle bore, making sure lubrication hole in bushing is aligned with lubrication fitting in steering knuckle, and open end of oil groove is toward axle. Using a driver which pilots in bushing, drive bushing into place in knuckle (Delrin bushings can be forced into place by hand). Ream bronze bushings until inside diameter of bushing is .001-.003" larger than outside diameter of kingpin. Clean all metal shavings from bushing after reaming. Lubricate bushing and kingpin, and install steering knuckle on vehicle as previously described. Install shims between top of axle and steering knuckle, to obtain .003-.010" axle-to-knuckle clearance.

FRONT AXLE

Removal — Raise vehicle and position safety stands under frame. Remove steering knuckle and front spring as previously outlined. Remove stabilizer bar if equipped. Remove lower spring seat from radius arm. Remove bolt connecting radius arm and bracket to front axle. Remove axle pivot bolt and remove axle.

Installation — Position axle and install pivot bolt and nut finger tight. Connect radius arm and front bracket, and install and tighten bolt. Install lower spring seat, making sure it aligns over radius arm bolt. Install coil spring as previously outlined. Tighten axle pivot bolt. Install steering knuckle as previously outlined, and stabilizer bar if equipped.

COIL SPRING

Removal — Raise front of vehicle, place safety stands under frame and a floor jack under axle. Disconnect lower shock absorber mount. Remove bolts securing upper spring retainer and remove retainer. Remove nut securing lower spring

retainer to spring seat and axle. Lower jack under axle and remove spring.

Installation — Place spring in position and raise front axle with jack. Place lower spring retainer over stud and lower seat, and tighten attaching nut. Place upper retainer over spring and upper seat and tighten bolts. Connect lower shock absorber mount. Remove jack, and safety stands and lower vehicle.

RADIUS ARM

Removal — Raise vehicle and position safety stands under frame and a floor jack under axle. Disconnect lower shock absorber mount. Remove front spring as previously outlined. Remove lower spring seat and remove bolt securing radius arm to axle. Remove cotter pin, nut, rear washer and insulator from rear radius arm mount. Remove radius arm.

Installation — To install radius arm, reverse removal procedure.

TIGHTENING SPECIFICATIONS

Application	Ft. Lbs.
Upper Shock Absorber Mount	
"E" Models.....	18-28
"F" Models.....	15-25
Lower Shock Absorber Mount.....	40-60
Shock Absorber Bracket-to-Radius Arm.....	70-90
Upper Spring Retainer-to-Spring Seat	
"E" Models.....	20-30
"F" Models.....	10-40
Lower Spring Retainer-to-Spring Seat.....	30-70
Radius Arm-to-Front Axle.....	240-320
Radius Arm-to-Bracket.....	80-120
Front Axle Pivot Bolt.....	120-150
Kingpin Lock Pin.....	38-62
Kingpin Plug.....	35-50