

Wheel Alignment

GENERAL MOTORS

CHEVROLET & GMC WITH COIL SPRINGS

NOTE — Difference in shim packs must not exceed .300". Front shim pack must be .240" minimum and .740" maximum thickness. Rear shim pack must be .590" maximum thickness.

CAMBER

All Models — Camber is changed by adding or subtracting shims from the upper control arm shaft. To increase camber, add equal amounts of shims to both upper control arm attaching bolts. To decrease camber, subtract equal amounts of shims from both control arm attaching bolts. **NOTE** — By adding or subtracting equal amounts of shims, camber may be corrected without affecting caster.

CASTER

All Models — 1) Measure frame angle, in relation to level, directly behind cab. Using suitable alignment equipment, determine existing caster. Combine frame angle with caster angle to determine corrected caster angle as follows:

A) — If frame is down in rear, frame angle must be subtracted from positive caster angle.

B) — If frame is down in rear, frame angle must be added to negative caster angle.

C) — If frame is up in rear, frame angle must be subtracted from negative caster angle.

D) — If frame is up in rear, frame angle must be added to positive caster angle.

2) Measure distance from top of jounce bumper bracket on lower control arm to bottom of frame crossmember. Determine correct caster angle for measured clearance and adjust. To increase caster, add shims between forward upper control arm attaching bolt and frame, or subtract shims from rear attaching bolt. To decrease caster, subtract shims from forward bolt, or add shims to rear bolt.

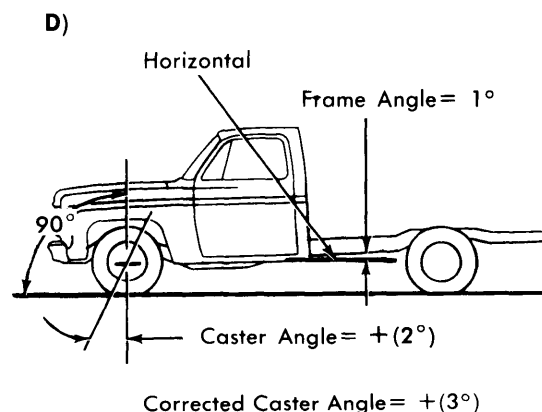
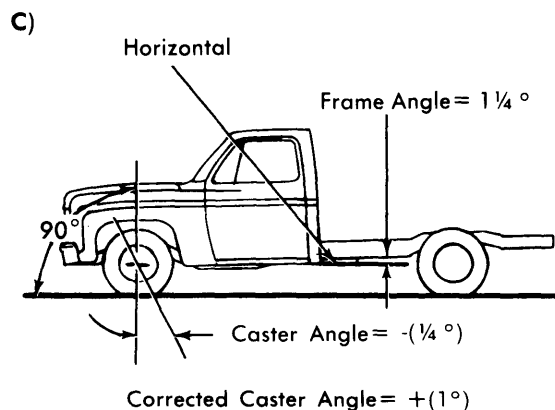
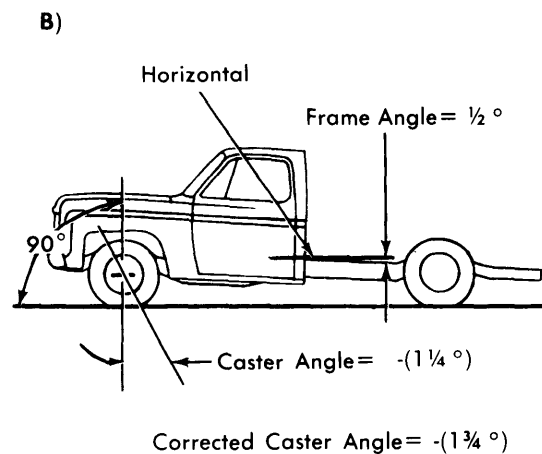
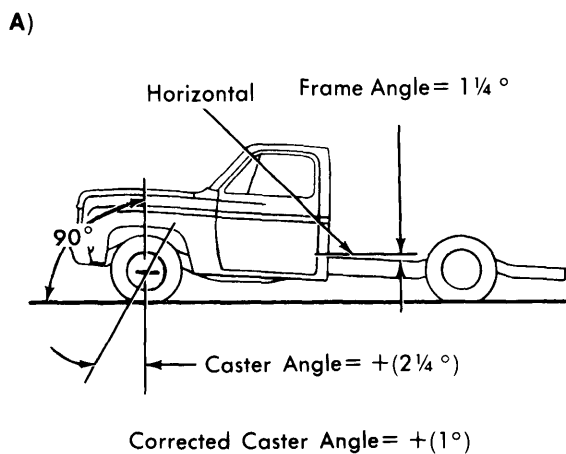

3CH13

DETERMINING CORRECTED CASTER ANGLE

GENERAL MOTORS (Cont.)

GMC MOTOR HOME

RIDING HEIGHT

Front — Riding height is measured from floor-to-oval hole in frame approximately two feet behind centerline of front wheel. To adjust riding height, raise vehicle and support under frame. Clean threads of adjusting bolt and apply grease to threads. Turn adjusting bolt clockwise to raise vehicle, and counterclockwise to lower vehicle. **CAUTION** — Do not turn adjusting bolt while vehicle is on ground, as this will strip threads of adjusting bolt.

Rear — Riding height is measured from floor-to-oval hole in frame approximately four feet (depending on model) behind rear wheels. To adjust riding height, loosen adjustment nut on height control valve, and manually operate overtravel lever until correct riding height is obtained. Tighten adjustment nut to 70-80 ft. lbs.

CAMBER

Front — Camber is controlled by eccentric bolts which mount upper control arm to frame. To increase camber, loosen eccentric bolt lock nuts and turn both eccentric bolts an equal amount to force upper control arm outward. To decrease camber, turn both bolts an equal amount to pull upper control arm inward. **NOTE** — Turning both bolts an equal amount will change camber without affecting caster. Tighten eccentric bolt lock nuts.

Rear — Adjustment of rear wheel camber is accomplished by inserting shims between rear suspension mounting bracket and frame. Raise vehicle and loosen suspension mounting bracket

bolts. Insert horizontal shims between frame and bracket to increase camber. Remove shims to decrease camber. **NOTE** — Vertical shims are used to control rear wheel toe-in, and should be left in place when adjusting camber.

CASTER

Front — Caster is controlled by eccentric bolts which mount upper control arm to frame. Loosen front and rear cam nuts. **NOTE** — Hold bolts so camber setting is not changed. Rotate front cam bolt so camber changes $\frac{1}{4}$ of the amount caster needs to be corrected. Rotate rear cam bolt so camber returns to correct setting. Recheck caster and repeat procedure if necessary. Tighten eccentric bolt lock nuts to 110 ft. lbs.

Rear — Caster is preset at factory, and no adjustment is provided. If not within limits, replace parts as necessary to correct.

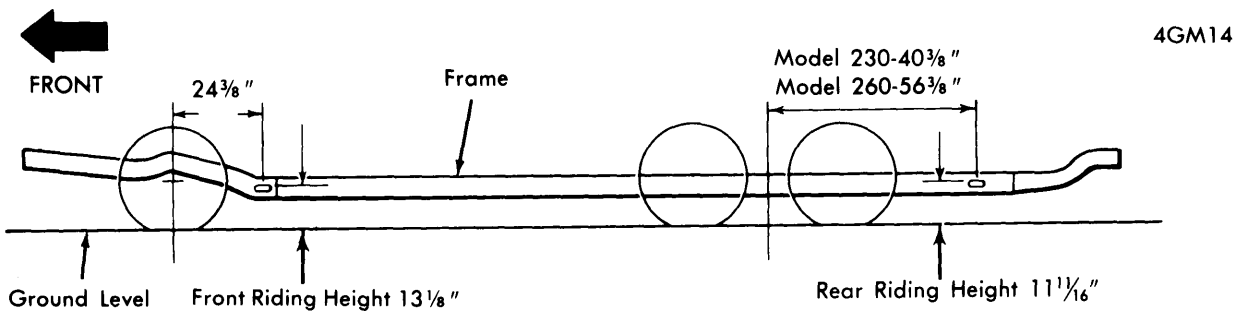
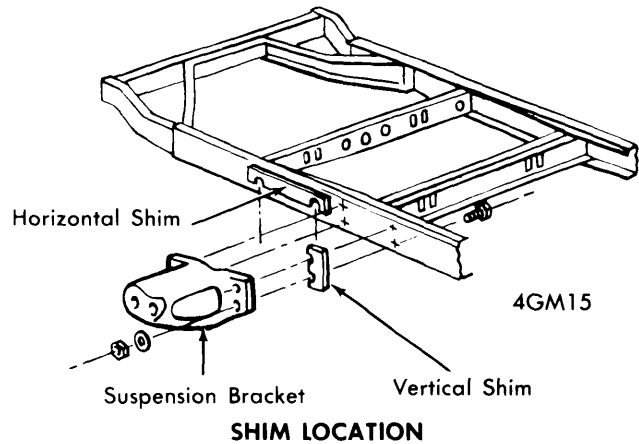

GMC MOTOR HOME RIDING HEIGHT