

## WHEEL ALIGNMENT PROCEDURES

### ADJUSTMENT CAUTIONS

Before making wheel alignment adjustments, check the following:

- 1) Wheel bearings must be properly adjusted.
- 2) Steering linkage and suspension must not have excessive looseness. Check for wear in tie rod ends and ball joints.
- 3) Tires should be approximately equal in tread wear and runout must not be excessive. Tires and wheels should be in balance, and inflated to manufacturer's specifications.
- 4) Vehicle must be at curb height with full fuel load, no passenger load, spare tire in place but no extra load in vehicle.
- 5) Vehicle must be on level floor with suspension settled. Bounce front and rear of vehicle several times and allow it to settle to normal running height.
- 6) If steering wheel is not centered with front wheels in straight ahead position, correct by shortening one tie rod adjusting sleeve and lengthening opposite sleeve equal amounts.
- 7) Ensure wheel lug nuts are tightened to manufacturer's specifications.

WHEEL LUG NUTS TIGHTENING SPECIFICATIONS (Cont.)	
Application	Ft. Lbs.
<b>GMC</b>	
K1500 .....	70-90
All Other 1500 Series .....	75-100
2500/3500 Series	
W/Single Wheels .....	90-120
W/Dual Wheels .....	110-140
W/H.D. Wheels .....	130-180
Motor Home Chassis .....	250
<b>International Harvester</b>	
W/1/2"-20 Lug Nuts .....	70-90
W/3/16"-18 Lug Nuts .....	110-125
W/5/8"-18 Lug Nuts .....	125-140
<b>Jeep</b>	
"CJ" Models .....	65-90
All Other Models .....	65-80
<b>Plymouth</b>	
"PD" & "PW" Models .....	85-105
PB100/200 .....	65-85
PB300	
W/Single Wheels .....	127-175
W/Dual Wheels .....	300-350

WHEEL LUG NUTS TIGHTENING SPECIFICATIONS	
Application	Ft. Lbs.
<b>Chevrolet</b>	
K10 .....	70-90
All Other 10 Series .....	75-100
20/30 Series	
W/Single Wheels .....	90-120
W/Dual Wheels .....	110-140
W/H.D. Wheels .....	130-180
<b>Dodge</b>	
AD100, AW100 .....	85-105
All Other 100/200 Series .....	65-85
B300	
W/Single Wheels .....	127-175
W/Dual Wheels .....	300-350
D300, W300	
W/Single Wheels .....	127-175
W/Dual Wheels .....	450-500
M300/400 .....	300-350
M500 .....	400-450
<b>Ford</b>	
E100/150 .....	90
E250/350	
W/Single Wheels .....	135
W/Dual Wheels .....	210
P350	
W/Single Wheels (1/2"-20 nut) .....	90
W/Single Wheels (3/16"-18 nut) .....	135
W/Dual Wheels .....	210
U100 .....	90
F100/250 .....	90
F350	
W/Single Wheels .....	135
W/Dual Wheels .....	210

### CAMBER

Camber is the tilting of the wheel, outward at either top or bottom, as viewed from the front of vehicle. When wheels tilt outward at the top from the centerline of vehicle, camber is said to be positive. When wheels tilt inward at the top, camber is said to be negative. Amount of tilt is measured in degrees from vertical.

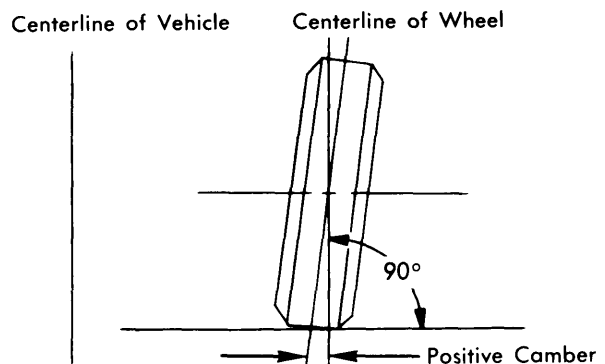

4CH01

### CAMBER ANGLE

### CASTER

Caster is the tilting of front steering axis, either forward or backward from vertical, as viewed from side of vehicle. When axis is tilted backward from vertical, caster is said to be positive, creating a trailing action on front wheels. When axis is tilted forward, caster is negative, causing a leading action on front wheels.

# Wheel Alignment

## WHEEL ALIGNMENT PROCEDURES (Cont.)

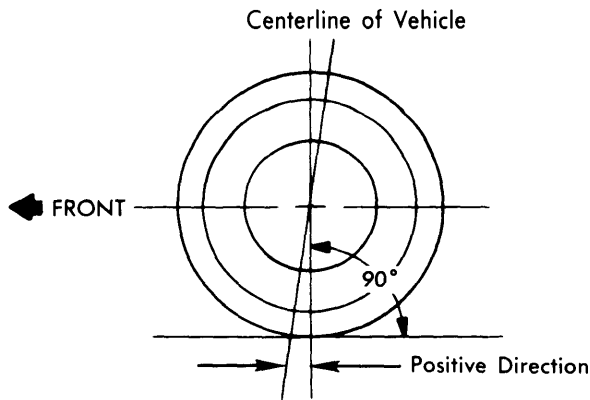

4CH02

**CASTER ANGLE**

### TOE-IN ADJUSTMENT

Measure toe-in with front wheels in straight ahead position and steering wheel centered. Adjust toe-in by loosening clamps and turning adjusting sleeve or adjustable end on right and left tie rods equally and in opposite directions to maintain steering wheel in centered position. **CAUTION** — Face of tie rod end must be parallel with machined surface of steering rod end to prevent cocking and binding of the ball end in service. When tightening clamps, make certain that that clamp bolts are positioned so there will be no interference with other parts throughout entire travel of linkage.

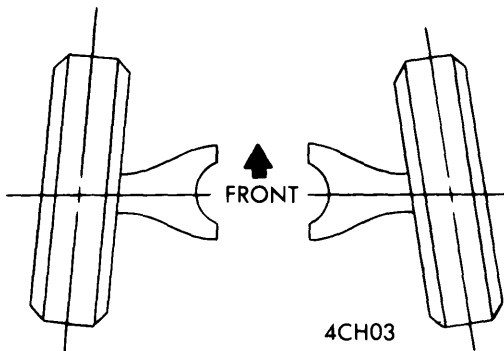

**WHEEL TOE-IN**

### TOE-OUT ON TURNS

Toe-out check is a check for bent or damaged parts, and not a service adjustment. With caster, camber, and toe-in properly adjusted, check toe-out with weight of car on wheels (use full-floating turn table under each wheel), repeating test with each wheel positioned for right and left turns. Incorrect toe-out generally indicates a bent steering arm. Replace arm and recheck all wheel alignment adjustments. **CAUTION** — Do not attempt to correct by straightening parts.

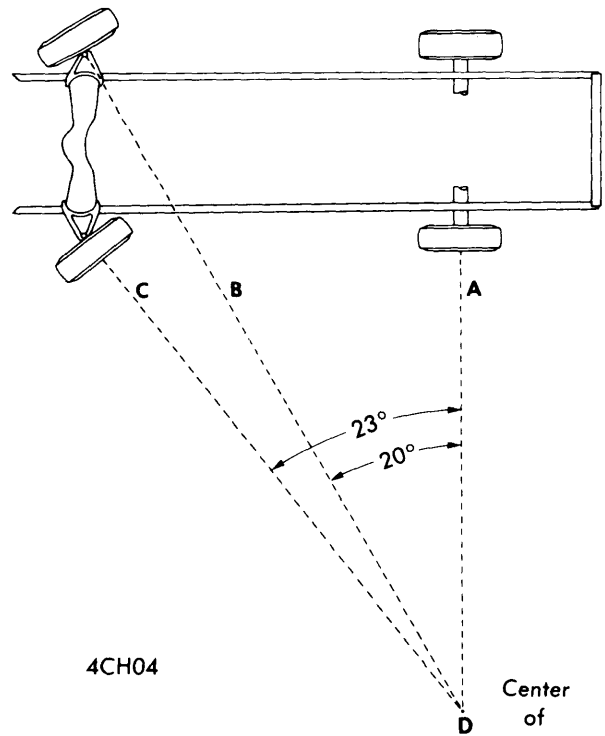

**WHEEL TOE-OUT**

### STEERING AXIS INCLINATION

This is a check for bent or damaged parts, and not a service adjustment. Vehicle must be level (crosswise and lengthwise) and camber should be properly adjusted. If camber cannot be brought within limits and steering axis inclination is correct, steering knuckle is bent. If camber and steering axis inclination are both incorrect by approximately the same amount, upper and lower control arms are bent. Replace parts, and recheck all front end adjustments. **CAUTION** — Do not attempt to correct by straightening parts.

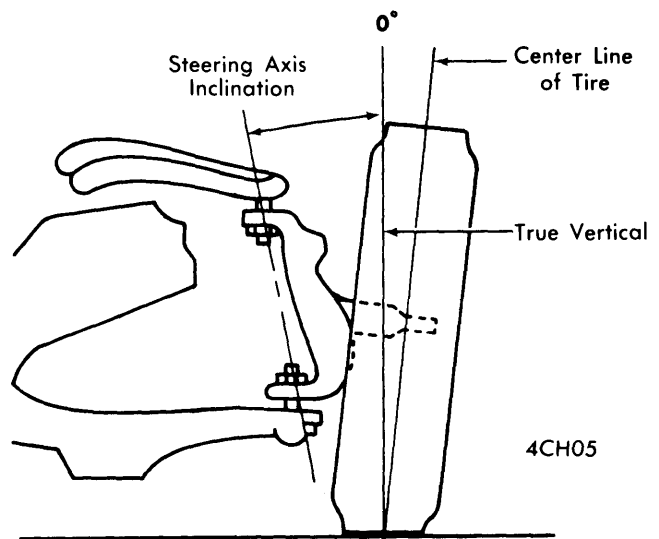

**STEERING AXIS INCLINATION**