

# Brake Systems

## GENERAL MOTORS DUAL CYLINDER DUO-SERVO

Chevrolet  
GMC

### DESCRIPTION

Dual cylinder floating shoe rear brake assemblies consist of a support plate, two brake shoes, return springs, two adjusting screws, two wheel cylinders, and automatic adjuster components. Automatic adjusters consist of two connecting links, override levers, override springs, and two actuating levers. Normal adjustment is accomplished through movement of brake shoes and actuating levers during reverse brake application.

### ADJUSTMENT & SERVICING

#### BRAKE SHOE ADJUSTMENT

**Recommended Method** – With brake drum removed, disengage actuating levers from star wheel adjusters. Using

suitable brake drum gauge, measure diameter of drum clearance surface. Adjust brake shoe diameter by turning star wheels until gauge just slides over shoes. Rotate gauge around shoes to assure proper clearance. Install brake drum and wheel, and make several forward and reverse stops to complete adjustment.

**Alternate Method** – With brake drum removed, disengage actuating levers from star wheel adjusters. Using the brake drum as a gauge, adjust brake shoes until drum slides over shoes with a slight drag. Turn star wheels  $1\frac{1}{4}$  turns each to retract shoes. Install drum and wheel, and make several forward and reverse stops to complete adjustment.

#### BLEEDING SYSTEM

See *Hydraulic Brake Bleeding* in this Section.

#### PARKING BRAKE ADJUSTMENT

See *Parking Brake Adjustment in General Motors Single Anchor Brake System* in this Section.

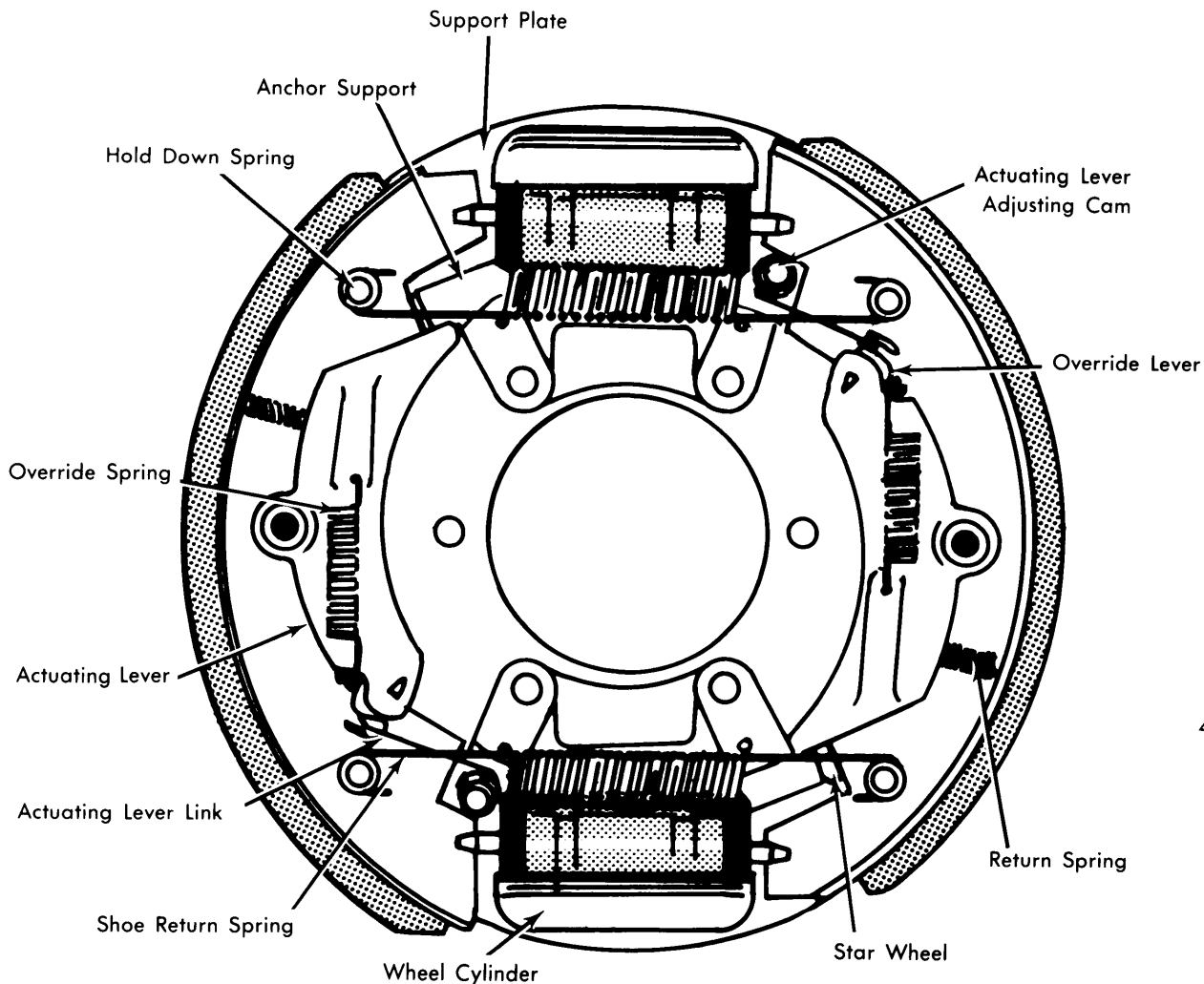

4CH01

**DUAL CYLINDER BRAKE ASSEMBLY**

## GENERAL MOTORS DUAL CYLINDER DUO-SERVO (Cont.)

### REMOVAL & INSTALLATION

#### BRAKE SHOES

**Removal** — With vehicle raised off floor, remove brake drum. Remove brake shoe return springs, then loosen actuating lever cam cap screws. Hold actuating levers away from star wheels and remove cap screws and cams. Remove brake shoe hold down springs and pins and lift brake shoes and automatic adjusters from support plate as an assembly. Remove automatic adjusters from shoes and separate shoes. Thread adjusting screws out of anchor plate and remove and discard friction springs.

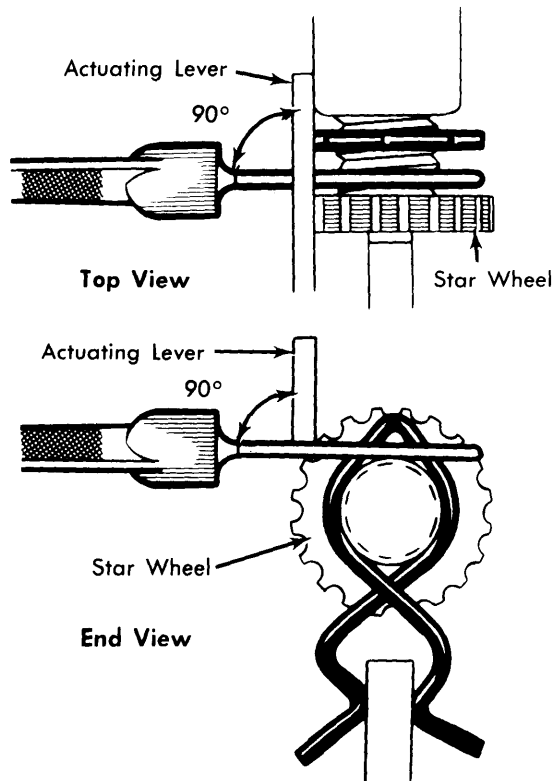

4CH02

#### ACTUATOR LEVER ADJUSTMENT

**Installation** — Lightly lubricate contact points of support plate and threads of adjusting screws with high temperature grease. Position NEW friction springs on adjusting screws and thread screws into anchor plate. Assemble automatic adjusters on brake shoes and install shoes on support plate. Install brake shoe return springs, position adjusting lever cam into actuating lever link and assemble with cap screw. With brake shoes centered, turn adjusting screw two full turns out from fully retracted position. Hold a .060" plug gauge at 90° angle with star wheel edge of adjusting lever and turn adjusting cam until actuating lever and threaded area of adjusting screw just touch gauge. Tighten adjusting cam cap screw and retract adjusting screw. Install brake drums and wheels, and lower vehicle. Make several forward and reverse stops to be sure shoes are in adjustment.

#### WHEEL CYLINDER

**Removal & Installation** — Remove wheel, drum and brake shoes. Remove cylinder connecting links and disconnect hydraulic lines from cylinders. Remove brake cylinder retaining bolts and remove cylinders from support plate. To install, reverse removal procedure.

### OVERHAUL

#### WHEEL CYLINDER

**Disassembly** — Remove rubber boots from ends of cylinders. Remove cylinder cups, pistons, expanders, and piston return spring from cylinders. Remove bleeder screws and inspect bores for damage.

**Reassembly** — Soak rubber cylinder cups in suitable brake fluid or assembly lubricant and reverse disassembly procedure. *NOTE* — It is not necessary to clamp cylinder ends, as lips of wheel cylinder boots will retain pistons.

#### TIGHTENING SPECIFICATIONS

Application	Ft. Lbs.
Brake Hose Attaching Nut .....	18
Equalizer Nut.....	18
Support Plate Attaching Nut.....	150
Application	Inch Lbs.
Brake Line Nut.....	150
Wheel Cylinder Attaching Bolts .....	50
Brake Line Clips.....	150

### BRAKE SYSTEM SPECIFICATIONS

Application	Drum Diam.	Wheel Cylinder Diameter		Master Cylinder
		Front	Rear	Diameter
Chevrolet C, P30 W/11000 Lb. Axle	15"	⊙	1 ½"	.....
GMC C, P3500 W/11000 Lb. Axle	15"	⊙	1 ½"	.....

⊙ — Front disc brakes are standard equipment.