

Ball Joints

1965-74 BALL JOINT CHECKING

FACTORY RECOMMENDED METHOD

CHRYSLER CORP.

Lower Ball Joint (1970-71) — Ball joints should not be replaced if axial end play (up and down movement) is less than .070". Looseness of this nature is not detrimental and will not affect front end wheel alignment.

Lower Ball Joint (1972-74) — Ball joints are factory preloaded for zero axial end play. If any axial end play (up and down movement) is observed, ball joint should be replaced.

GENERAL MOTORS (EXCEPT GMC MOTOR HOME)

Upper Ball Joint (1965-71) — Raise and support vehicle under frame, allowing lower control arms to hang free. Remove wheel, and position suitable jack under lower control arm. Disconnect upper ball joint stud from steering knuckle, then reinstall nut only on ball joint stud. Measure torque required to rotate ball joint stud in ball joint assembly. If torque is not within 5-10 ft. lbs. range, replace ball joint.

Upper Ball Joint (1972-74) — Raise and support vehicle under frame, allowing control arms to hang free. Remove wheel and disconnect upper ball joint stud from steering knuckle. Attempt to twist and shake ball joint stud. If ball joint stud has any perceptible lateral shake, or if stud can be twisted in its socket, ball joint assembly should be replaced.

Lower Ball Joint — Lower ball joints are a loose fit when not connected to steering knuckle, thus wear may be checked without removing ball stud from steering knuckle. Raise and support vehicle under lower control arms, as close to ball joint as possible. Measure distance between upper tip of ball joint stud and tip of grease fitting mounted to bottom of ball joint. Move vehicle supports to a position under frame, allowing lower control arms to hang free. Again measure distance between ball joint stud and grease fitting. If difference between two measurements exceeds $\frac{3}{32}$ ", replace ball joint assembly.

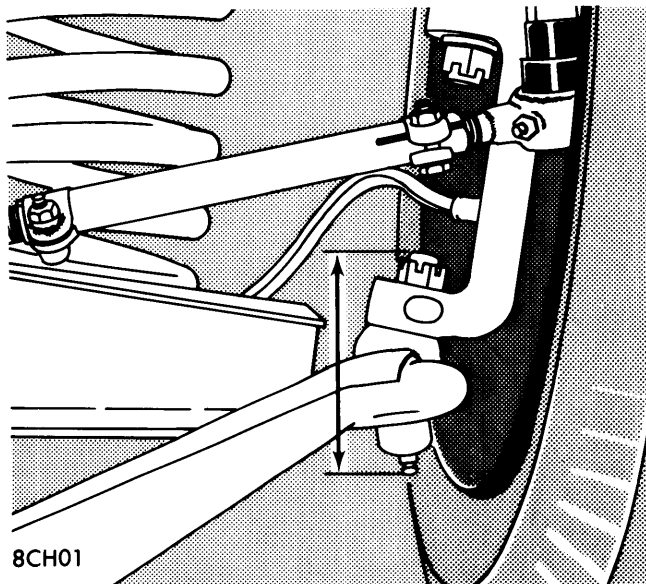

CHECKING LOWER BALL JOINT

GMC MOTOR HOME

Raise and support vehicle under lower control arms. Clamp self-locking pliers on hub at axle drive nut, so that pliers are in a horizontal position. Using a suitable stand, mount dial indicator so that contact tip of indicator points downward and rests against pliers. Place pry bar between lower control arm and drive axle outer race, and pull down on bar. If dial indicator reading exceeds .125", replace ball joint.

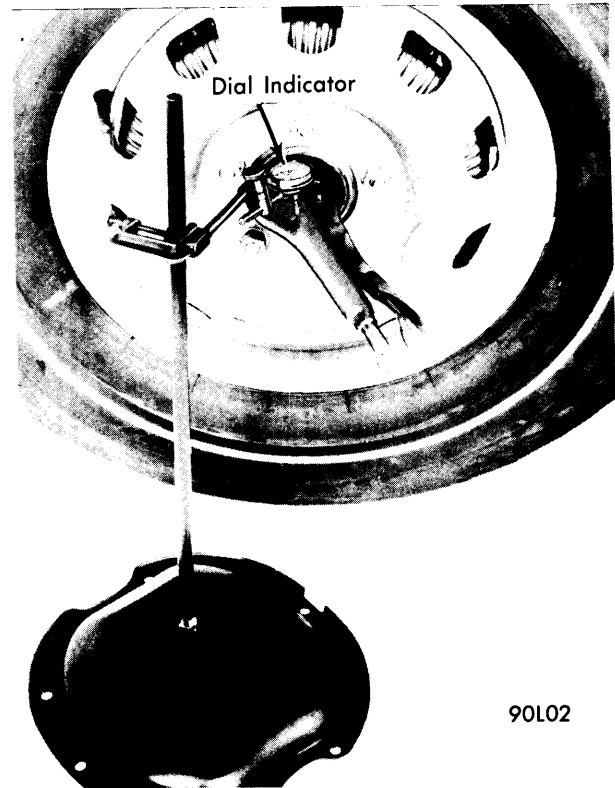

BALL JOINT VERTICAL CHECK

INTERNATIONAL HARVESTER

NOTE — Manufacturer gives no method for checking ball joints. See Alternate Method.

JEEP

NOTE — Manufacturer gives no method for checking ball joints. See Alternate Method.

ALTERNATE METHOD

NOTE — There are two general types of suspensions, one type with spring or torsion bar attached to upper control arm, and the other with spring or torsion bar attached to lower control arm. Check axial play by moving wheel up and down. Check radial play by rocking wheel at top and bottom.

1965-74 BALL JOINT CHECKING (Cont.)

SPRING ON LOWER CONTROL ARM

Upper Ball Joint — Replace ball joint if there is any perceptible looseness at joint.

Lower Ball Joint — If radial play, measured at bottom of tire on side wall, exceeds .250", replace ball joint assembly.

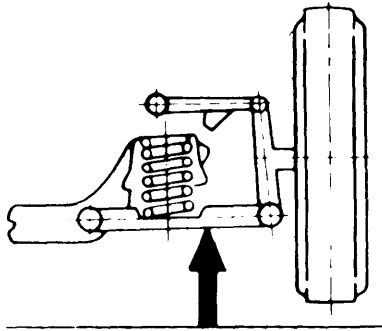

JACKING LOCATION

3F469-3F471

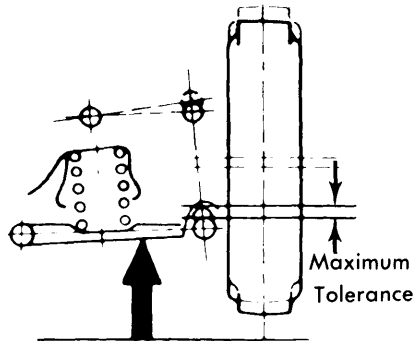

CHECKING AXIAL PLAY

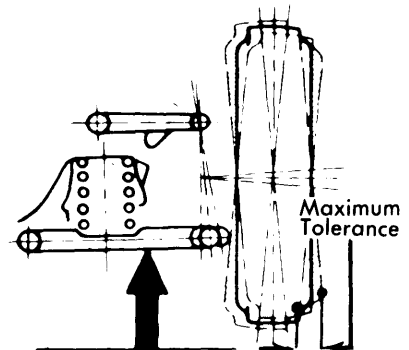

CHECKING RADIAL PLAY

SPRING ON LOWER CONTROL ARM

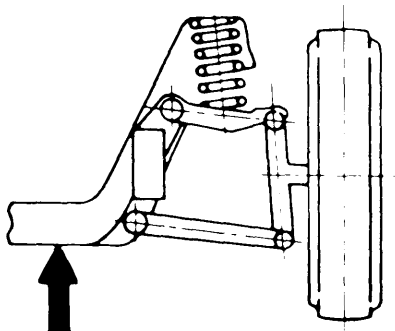

JACKING LOCATION

3F466-3F468

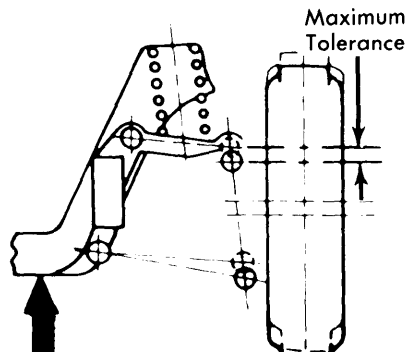

CHECKING AXIAL PLAY

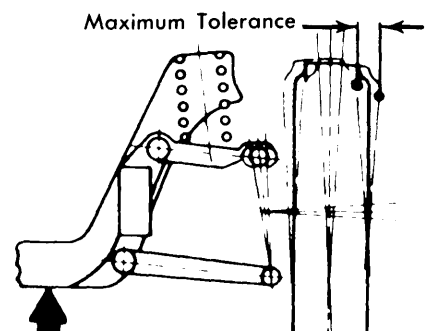

CHECKING RADIAL PLAY

SPRING ON UPPER CONTROL ARM

SPRING ON UPPER CONTROL ARM

Upper Ball Joint — If radial play, measured at top of tire on side wall, exceeds .250", replace ball joint assembly.

Lower Ball Joint — Replace ball joint if there is any perceptible looseness at joint.

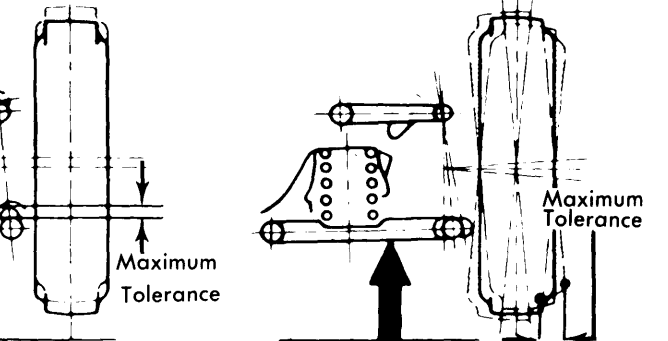

CHECKING RADIAL PLAY

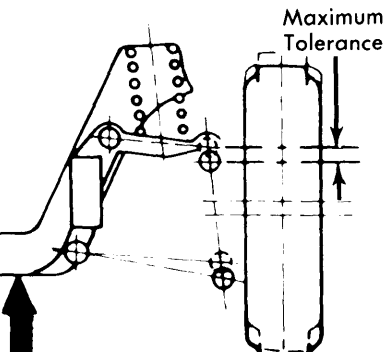

CHECKING AXIAL PLAY

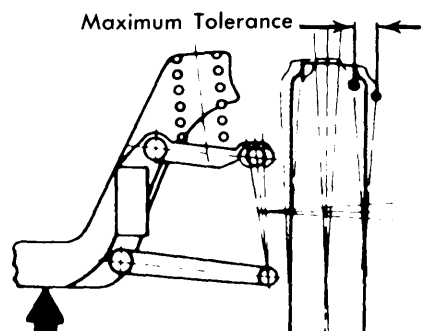

CHECKING RADIAL PLAY