

## IHC ANTI-SKID BRAKE SYSTEM

International Harvester (1972-74)

### DESCRIPTION

System is designed to prevent loss of control during emergency or severe stop. System avoids lock-up of rear wheels by sensing wheel speed and regulating hydraulic pressure to wheel cylinders as required. System consists of three major components: Speed sensors, pressure modulator, and electronic control unit.

**Speed Sensors** – Sensors are electromagnetic devices, mechanically driven by a drive ring. They consist of a stationary permanent magnet and coil in a case, and a tone wheel, both attached to a mounting bracket. A part of mounting bracket forms a spring to hold knurled shaft of tone wheel in contact with a band of rubber pressed into drive ring. Drive ring is mounted between axle flange and drum and rotates with rear wheel.

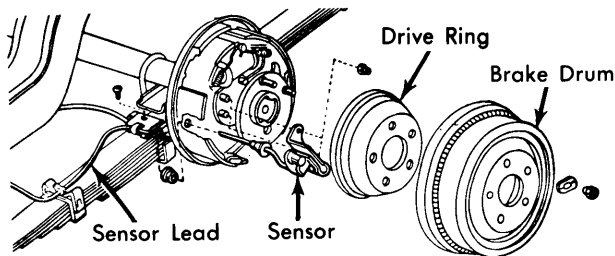

1CR01

**SPEED SENSOR MOUNTING**

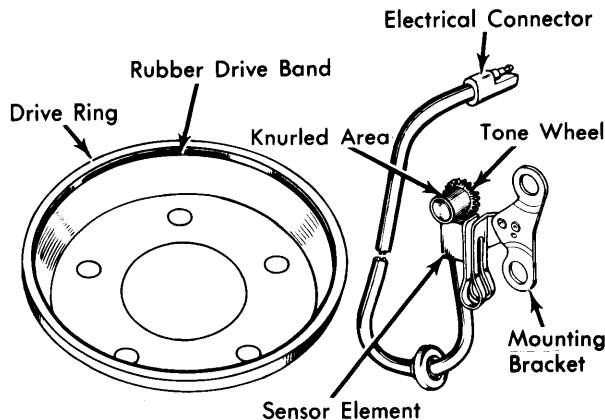

2IH02

**SPEED SENSOR DETAIL**

**Pressure Modulator** – Modulator consists of vacuum chamber, bypass tube, end plate, air valve, bypass valve, and pressure modulator switch. Engine vacuum is made available to modulator. Hydraulic tubing for rear brakes is routed from master cylinder, through brake warning light switch to pressure modulator, and then to rear brakes. Modulator vacuum chamber is divided into a front and rear section by a diaphragm and diaphragm plate. Diaphragm return spring holds diaphragm plate against end plate. Hydraulic cylinder is an integral part of end plate. Cylinder has one port that is connected to master cylinder and another port that is connected to rear wheels. A shutoff valve and a displacement plunger are

assembled inside hydraulic cylinder. Air valve and bypass valve are attached to end plate. Both of these valves are solenoid operated. A bypass tube connects bypass valve to rear of vacuum chamber. Modulator switch is spring-loaded and screws into a threaded opening in end plate. Switch breaks a circuit to provide a warning signal under certain conditions (See Warning System in this Article).

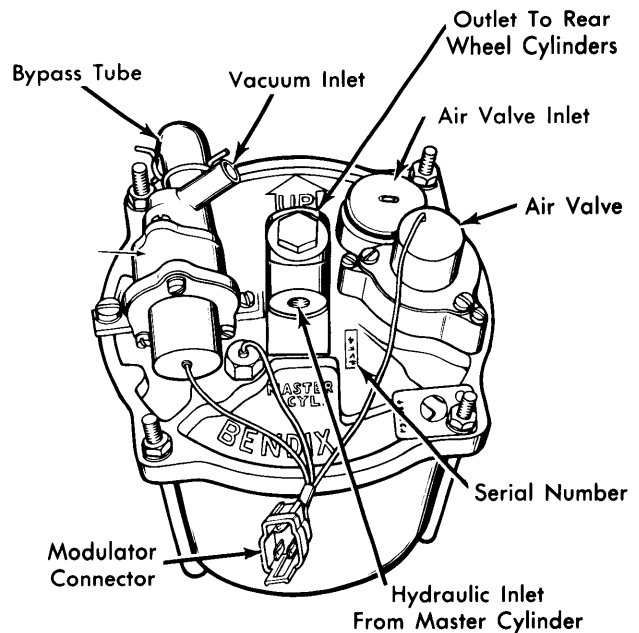

4IH03

**PRESSURE MODULATOR**

**Electronic Control Unit (ECU)** – Control unit is essentially a small computer and contains various electronic components. Unit is encased in a container and includes three external connectors and cables.

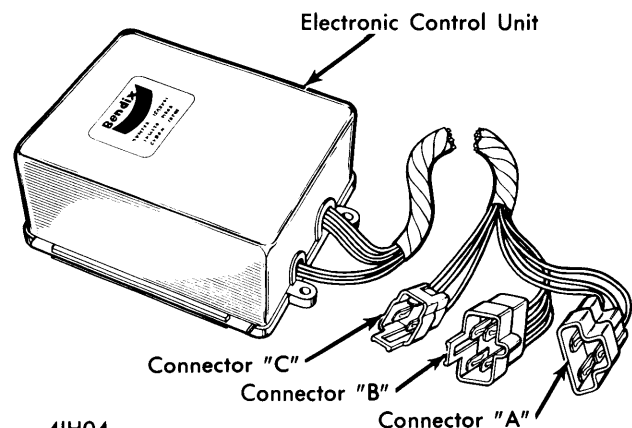

4IH04

**ELECTRONIC CONTROL UNIT (ECU)**

## IHC ANTI-SKID BRAKE SYSTEM (Cont.)

### OPERATION

#### ENGINE RUNNING

**Vehicle Not In Motion** — Without signals from sensors, ECU does not function. Modulator air valve is closed, bypass valve open, and vacuum admitted to front and rear of chamber. Diaphragm is balanced in vacuum and return spring holds plate forward against end plate. If brakes are applied under these conditions, full hydraulic pressure from master cylinder passes through modulator hydraulic cylinder to rear wheel cylinders. *NOTE — For descriptive purposes any diaphragm plate movement that compresses diaphragm return spring is described as "rearward", and any movement of diaphragm plate towards end plate is described as "forward."*

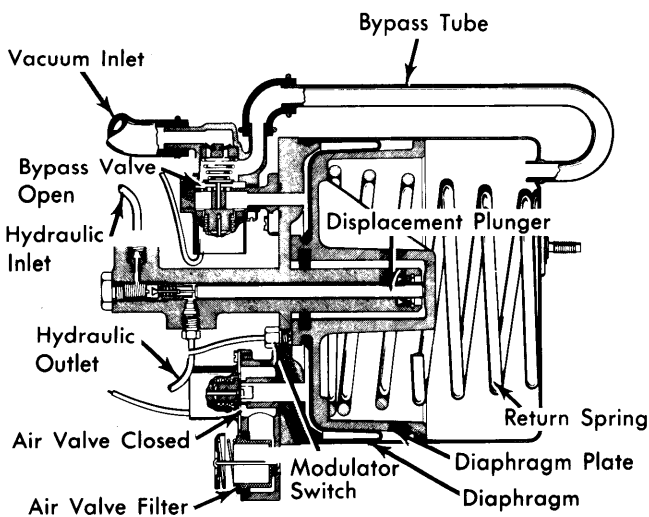

4IH05

#### PRESSURE MODULATOR — INACTIVATED (INLET & OUTLET SHOWN OUT OF POSITION) (TYPICAL)

**Vehicle In Motion** — 1) When vehicle is in motion, an alternating current is generated at each speed sensor and sent to ECU. Frequency of AC voltage is directly proportional to speed of vehicle. ECU processes signals received from sensors. If brakes are not applied or if they are applied lightly, ECU does not send any commands to pressure modulator. If brakes are applied with greater force, the ECU, based on signals received from speed sensors, determines rate at which each rear wheel is decelerating.

2) If rate of deceleration of either rear wheel is great (at a point that might produce excessive wheel slippage or wheel lockup), ECU sends a command to modulator which does two things: It closes modulator bypass valve which shuts off vacuum to front section of vacuum chamber, and it opens modulator air valve which permits atmospheric pressure to enter front section of vacuum chamber. The pressure differential created moves diaphragm, diaphragm plate, and displacement plunger rearward.

3) A slight movement of displacement plunger rearward closes shutoff valve in hydraulic cylinder which isolates rear brake wheel cylinders from master cylinder hydraulic pressure. Continued movement of displacement plunger provides additional space for fluid trapped between hydraulic shutoff valve and rear wheel cylinders. This permits a small amount of fluid to return from wheel cylinders to modulator, and thus reduces pressure at wheel cylinders. With pressure reduced, brakes are released to some degree and wheel speed starts to increase.

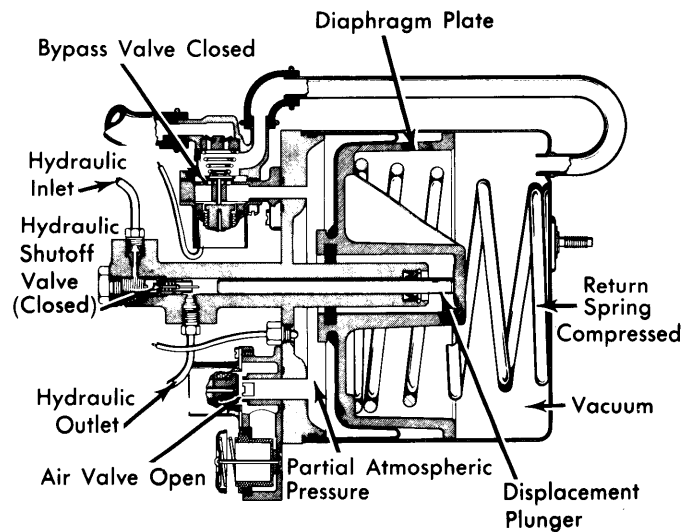

4IH06

#### PRESSURE MODULATOR — ACTIVATED (INLET & OUTLET SHOWN OUT OF POSITION) (TYPICAL)

4) Controller senses wheel speed increase, and by controlling air and bypass valves, determines rate at which hydraulic pressure increases and brake shoes at rear wheels are reapplied. Cycle is repeated until vehicle speed is reduced to approximately five MPH. At end of brake stop, diaphragm plate and displacement plunger should always move forward enough to open hydraulic shutoff in pressure modulator. When this happens, brake pedal may drop slightly.

*NOTE — Under some conditions, at speeds over five MPH, displacement plunger may move forward far enough to open hydraulic shutoff valve. If this happens, driver may notice a slight drop in brake pedal.*

#### EXERCISE CYCLE

If engine is started with brake pedal depressed (stop lights on), modulator goes through an exercise cycle which may be heard under some conditions. When ignition switch is turned from "OFF" to "ON" (on the way to "START" position), modulator cycles once. If switch is turned slowly with a pause at "ON" position, this cycle may be heard. These cycles are to insure that system is functioning properly and should not be a cause for concern.

## IHC ANTI-SKID BRAKE SYSTEM (Cont.)

### WARNING SYSTEM

A secondary system, using vehicle's brake warning light will warn driver of certain types of failure in system. Brake warning light comes on under following conditions:

- 1) If pressure modulator is activated (diaphragm and plate move to the rear) in absence of a brake light signal (brake pedal not depressed).
- 2) If ECU sends a signal to open modulator air valve and does not send a subsequent signal to open bypass valve.
- 3) If electrical continuity of air valve lead wire is broken.
- 4) If there is a blown fuse, loose connection, break in wire, or open circuit between ignition switch and ECU.

### REMOVAL & INSTALLATION

#### SPEED SENSORS

**Removal** - 1) Raise vehicle and remove tire, wheel and brake drum. Remove straps that secure speed sensor lead to hydraulic brake tube on rear axle housing and disconnect speed sensor connector. Press speed sensor toward axle (to reduce pressure of knurled shaft against drive band), and remove drive ring assembly.

2) Working through hole in axle flange, remove nut that secures sensor to backing plate and remove sensor. Unseat sensor lead grommet in backing plate and pull lead through hole in backing plate.

**Installation** - 1) Insert sensor lead through hole in backing plate and seat grommet in backing plate making sure that grommet is properly seated. Position sensor mounting bracket with lower forward brake mounting bolt in lower bracket hole and upper bracket hole around upper forward brake mounting nut. Secure bracket in place with lower nut (work through hole in axle flange).

2) Press speed sensor toward axle and position drive ring assembly on axle flange. Connect sensor connector and use straps to secure sensor lead to hydraulic tube on axle housing. Install drum, wheel, and tire and lower vehicle.

#### ELECTRONIC CONTROL UNIT

**Removal & Installation** - Disconnect the three ECU connectors located on left side of instrument panel. Remove screws that hold ECU to instrument panel and remove ECU from vehicle. To install, reverse removal procedure.

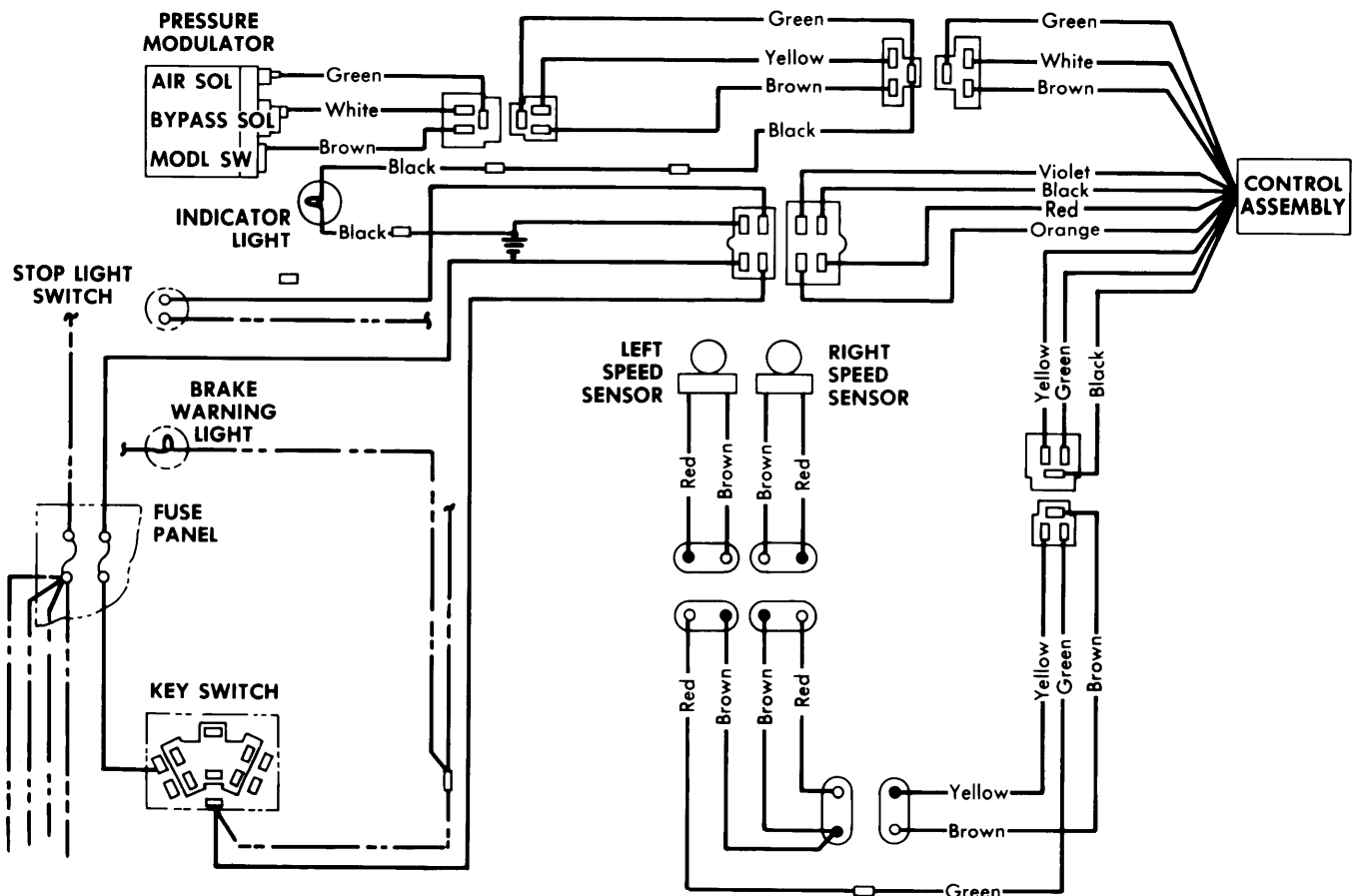

ELECTRIC CIRCUIT DIAGRAM

4IH07

## IHC ANTI-SKID BRAKE SYSTEM (Cont.)

### PRESSURE MODULATOR

**Removal** – 1) Disconnect vacuum hose from vacuum inlet on modulator bypass valve. Disconnect the two hydraulic tubes from modulator hydraulic cylinder. Disconnect modulator electrical connector located in engine compartment near modulator.

2) Loosen nut that secures rear of modulator (end toward front of vehicle) to mounting bracket. Then loosen outer nuts on two lower "J" bolts. Lift modulator upward to disengage modulator bolts from slots in mounting bracket and remove modulator from vehicle.

**CAUTION** – Do not attempt to disassemble modulator. Heavy duty diaphragm return spring is compressed inside modulator, and any attempt to remove "J" bolts and end plate could result in personal injury.

**Installation** – 1) Position modulator with bypass tube up on mounting bracket so that two lower "J" bolts and stud on rear of modulator fit into slots in mounting bracket. Tighten nut on stud at rear of modulator, then tighten outer nuts on two lower "J" bolts.

2) Connect hydraulic tube from brake warning switch to port on bottom of hydraulic cylinder and connect rear brake hydraulic tube to port on top of hydraulic cylinder. Connect vacuum hose to vacuum inlet on bypass valve. Connect modulator electrical connector.

### DISABLING ANTI-SKID BRAKE SYSTEM

If necessary parts are not available or for some other reason anti-skid brake system cannot be repaired, system should be disabled. Brakes will then function similar to those on vehicles without system and vehicle can be operated safely. Disable according to following procedure:

1) For most failures that occur, system can be completely disabled by disconnecting electronic control unit (all three connectors) and vacuum supply hose. Vacuum hose should be disconnected at manifold fitting and fitting plugged. Hose to modulator should be taped to keep dirt out.

2) An additional step is necessary to disable system for one type of failure that can occur. This is a failure that causes modulator diaphragm plate to stick in retracted or partially retracted position. To determine if plate is stuck in retracted position (and, therefore, hydraulic shutoff valve closed), open a bleeder screw at one of rear brakes while a helper presses on brake pedal. If fluid runs freely, shutoff valve is open. If fluid does not run freely, valve is closed.

3) If hydraulic shutoff valve is closed, hydraulic tubing to rear brakes must be routed to bypass modulator. Disconnect both hydraulic tubes from modulator, bend tubes slightly, and connect two tubes with an adapter and a tube union. Bypassing modulator hydraulically is in addition to disconnecting electrical and vacuum systems previously outlined. Road test vehicle and check braking action.