

# Power Brake Units

## BENDIX DUAL DIAPHRAGM

Chevrolet (1965-74)  
 Dodge (1970-74)  
 Ford (1968-74)  
 GMC (1965-74)  
 International Harvester (1965-74)  
 Jeep (1969-74)  
 Plymouth (1974)

NOTE — For other units used, see Power Brake Index.

### DESCRIPTION

Vacuum suspended power cylinder used with hydraulic brake system utilizes engine manifold vacuum and atmospheric pressure to provide power assisted brake application. Unit consists of three basic assemblies: vacuum power chamber comprised of front and rear shell, center plate, tandem front and rear diaphragms (with plate assembly), hydraulic push rod and vacuum diaphragm, and diaphragm return spring; mechanically actuated control valve integral with diaphragms; and a master cylinder.

### REMOVAL & INSTALLATION

NOTE — On following models, power brake unit can be removed without removing master cylinder or disconnecting hydraulic lines: 1973-74 Chevrolet & GMC, 1970-74 Dodge, 1968-74 Ford, 1965-74 International Harvester, and 1974 Plymouth.

### ALL (EXC. DODGE "B" & PLYMOUTH "PB")

**Removal** — Disconnect vacuum line from power unit. Remove hydraulic lines from master cylinder (see preceding NOTE). Disconnect pedal linkage and remove bolts holding power unit to firewall. Remove power unit from vehicle.

**Installation** — Reverse removal procedure, noting the following: Before attaching master cylinder, check push rod for proper length. See *Push Rod Adjustment* at end of this article. If hydraulic lines were disconnected, bleed system before moving vehicle.

### DODGE "B" & PLYMOUTH "PB" MODELS

**Removal** — Power unit is transverse mounted on firewall. Remove as follows: Disconnect vacuum hose from check valve. Remove master cylinder-to-power unit mounting nuts. Remove power unit push rod-to-bell crank bolt. Remove mounting bolts and remove power unit from vehicle.

**Installation** — To install, reverse removal procedure noting the following: Before attaching master cylinder, check push rod for proper length. See *Push Rod Adjustment* at end of this article.

### OVERHAUL

NOTE — The following manufacturers during years indicated, do not recommend overhaul of this power unit: 1970-74 Dodge, 1969-74 Ford, 1969-74 Jeep, 1974 Plymouth.

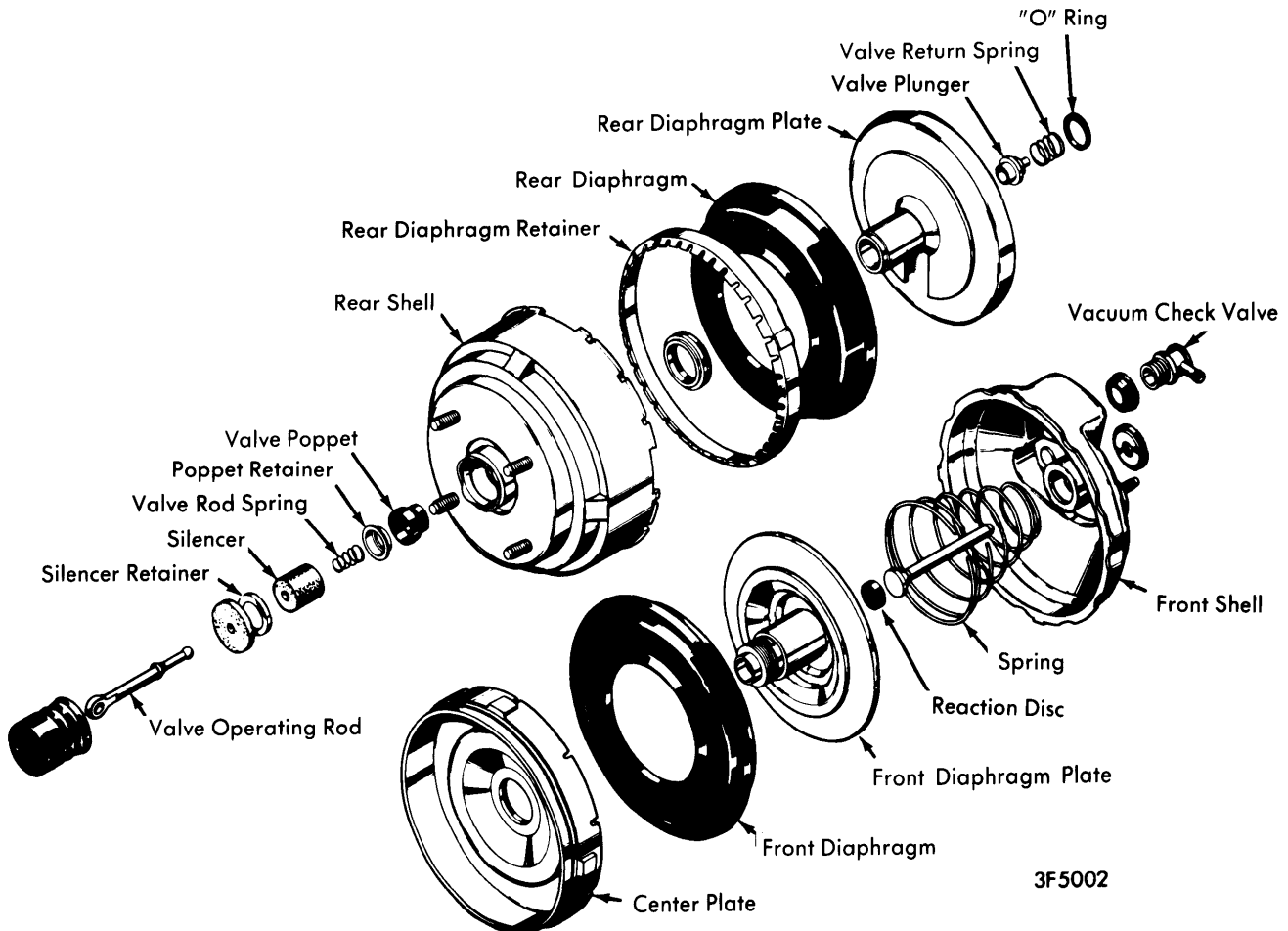

### BENDIX TANDEM DIAPHRAGM UNIT

## BENDIX DUAL DIAPHRAGM (Cont.)

**Disassembly – 1)** Scribe mark across master cylinder flange and power unit halves for reassembly. Remove master cylinder, then remove push rod and seal. Slide seal from rod. Remove vacuum check valve and grommet, if necessary. From rear housing air valve rod, remove dust boot and filter silencer. Extract air filter retainer, air filter, and silencer, using an awl or other suitable tool. Reinstall steel retainer to hub. Pour alcohol down valve operating rod (to aid removal), place end of rod in vise, and pry rod from unit (see illustration).

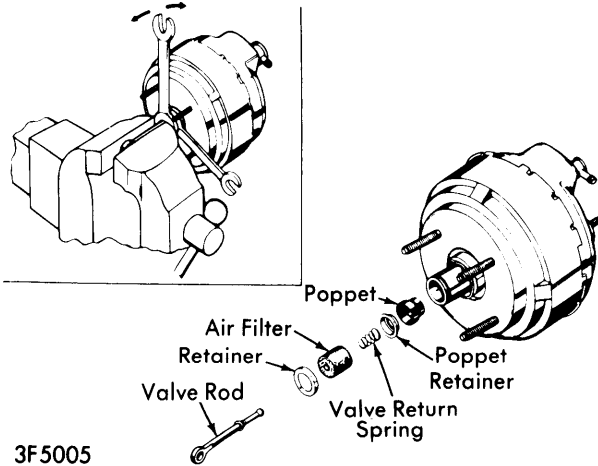

### VALVE ROD DISASSEMBLY & REMOVAL

**2)** Straighten four longest tabs on rear housing. Attach suitable separator tool (J-23456), apply slight downward pressure and turn front housing counterclockwise, release pressure on housing, then separate housings. Remove diaphragm assembly from rear housing. If necessary, use suitable tool and drive seal from rear housing. Wet rear diaphragm spring retainer with alcohol and remove diaphragm from rear plate (using fingers only).

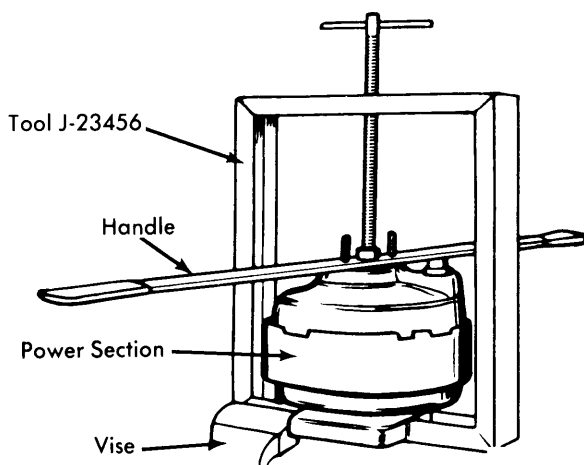

### SEPARATING FRONT & REAR HOUSINGS

**3)** Place 1 1/16" hex stock (2" long) in vise, or other suitable tool (J-22839), set diaphragm and plate assembly on tool, then twist rear plate counterclockwise until plates are loose. Remove assembly from tool and place on bench with front plate down.

Lift rear plate from front plate hub. Remove valve plunger and spring. Remove "O" ring. Push out reaction disc. Slide center plate from front plate hub.

**Cleaning & Inspection –** Clean all metal and rubber parts in alcohol. Remove rusted or corroded spots from metal areas with crocus or emery cloth. Dry all components with compressed air. Just before reassembly, rewash all metal components coming in contact with hydraulic fluid, in clean alcohol. Dry with compressed air. Use all parts included in repair kit and discard all old rubber parts.

**Reassembly – 1)** If rear bearing and seal were removed, install new parts, using suitable driver (J-22677). Install reaction disc to front plate hub, with small tip toward hole. Mount front plate on hex stock or other suitable tool (J-22839). Position diaphragm on front plate, with long fold facing down). Place suitable seal protector tool (J-22733) over hub threads, apply light coat of suitable lubricant to hub and seal in center plate, then guide center plate, seal first, onto hub. Lightly lube air valve plunger bearing surfaces (avoid lubing inner rubber grommet). Install vacuum "O" ring seal on shoulder of front plate hub, and insert valve plunger and return spring in base of front plate hub. Screw rear plate onto front plate hub, by hand (torque to 150 in. lbs.). Check travel of valve plunger with finger.

**2)** Assemble rear diaphragm to rear plate (place diaphragm lip in plate groove). Install rear diaphragm retainer. Apply talcum powder to inner wall of rear housing, and suitable lubricant to scallop cutouts and rear housing seal. Assemble diaphragm and plate assembly into rear housing (align center plate bosses between rear housing lances). Using screwdriver, work outer rim of diaphragm into rear housing. Attach rear housing to suitable tool (as used during separation – J-23456). Insert diaphragm return spring. Place front housing over rear housing (note location of scribe marks). Apply downward pressure until diaphragm edge is fully compressed, then rotate bar clockwise to lock housings. Remove from tool. Bend four tabs back to original position.

**3)** Dip poppet valve in clean alcohol and install in rear plate hub (small end first). Dip poppet retainer in alcohol and install it in poppet. Assemble retainer, filters, silencers, and return spring on valve rod. Dip valve plunger grommet in alcohol and install valve rod into plunger. Tap end of valve rod with plastic hammer to lock ball in grommet. Press filters and silencers into hub and install outer retainer. Assemble silencer in dust boot, wet boot with alcohol, and assemble on rod and over rear flange. Install check valve, if removed. Apply lubricant to piston end of hydraulic push rod and insert in cavity in front plate. Twist rod to eliminate air bubbles at reaction disc. Assemble seal over push rod and press into front housing recess.

## ADJUSTMENTS

### PUSH ROD ADJUSTMENT

**1)** Push rod height check or adjustment is required if master cylinder and power unit are separated, or if push rod is replaced or transferred from one unit to another, or if misadjustment is diagnosed as cause of braking problems.

**2)** Place gauge over push rod and adjust push rod nut to provide a slight tension (approx. 5 lbs.) against gauge. See *Push Rod Height chart and Push Rod Gauge Dimensions to fabricate suitable gauge.*

# Power Brake Units

## BENDIX DUAL DIAPHRAGM (Cont.)

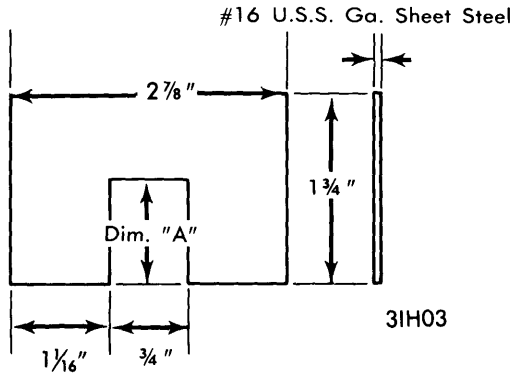

**PUSH ROD GAUGE DIMENSIONS**

PUSH ROD HEIGHT	
Application	Dimension "A"
Chevrolet & GMC	
1965-67 .....	1.195-1.200"
1968-74 .....	1.220-1.225"
Dodge .....	①
Ford .....	.880-.895"
International Harvester	
With Drum Brakes .....	.980-.995"
With Disc Brakes .....	1.185-1.200"
Jeep .....	② .980-.995"
Plymouth .....	①

① - Nonadjustable.  
 ② - Nonadjustable, push rod height of replacement unit is preset at factory.