

Power Steering Pumps

1965-74 SAGINAW VANE TYPE PUMPS

- Chevrolet (1965-74)
- Dodge (1968-74)
- GMC (1965-74)
- International Harvester (1965-74)
- Jeep (1969-74)
- Plymouth (1974)

NOTE — Some models use other units. See Thompson Slipper Type Pumps and Eaton Roller Type Pumps in this Section.

DESCRIPTION

The Saginaw vane type power steering pump can be identified by the oval shaped filler neck on pump reservoir (1965-73) or the "ham can" shape of the reservoir (1974). Internally, rectangular pumping vanes carried by a shaft driven rotor move fluid from intake pressure cavities of cam ring. As rotor begins to rotate, centrifugal force throws vanes against inside surface of cam ring to pick up residual oil, which is then forced into high pressure area. As more oil is picked up by the vanes, oil is forced into the cavities of the thrust plate and through two cross-over holes in cam ring and pressure plate (which empty into high pressure area between pressure plate and housing end plate). Filling high pressure area causes oil to flow under vanes in slots of rotor, forcing vanes to follow inside oval surface of cam ring. As vanes rotate to small area of cam ring, oil is forced out from between vanes.

LUBRICATION

Check fluid level on dipstick with fluid at normal operating temperature. Maintain level at indicated mark on dipstick, using only Power Steering Fluid.

ADJUSTMENT

DRIVE BELT

International Harvester — Loosen pump adjusting bracket bolt, and move pump in or out to obtain $\frac{3}{8}$ " deflection of belt at a point midway between pulleys. Tighten adjusting bracket bolt.

All Others — Loosen pump adjusting bracket bolt and move pump in or out to obtain proper drive belt tension. Tighten adjusting bracket bolt.

Tension (Using Strand Tension Gauge)

Application	Lbs.
Chevrolet.....	70-80
Dodge.....	70
GMC.....	90-100
Jeep.....	70-80
Plymouth.....	70

HYDRAULIC PRESSURE TEST

With fluid at correct level in reservoir, belt tension correctly adjusted, and power steering fluid at normal operating temperature, install suitable gauge between pump and high pressure hose. With engine idling at 600-800 RPM, and gauge valve open, note pressure reading while turning wheels from one stop to the other. Minimum pressure reading should be over 900 psi. If pressure is below 900 psi, momentarily close gauge valve and note maximum pressure obtained. If this reading is over 900 psi, steering gear is faulty. If reading is under 900 psi, power steering pump is faulty.

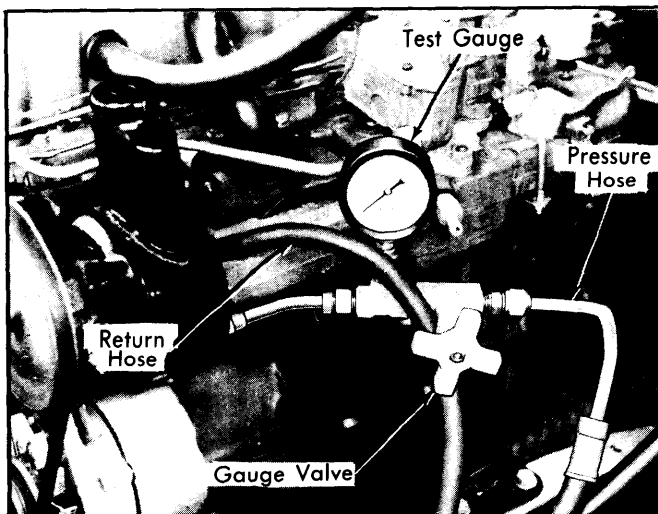

4D001

TESTING POWER STEERING PUMP

BLEEDING HYDRAULIC SYSTEM

International Harvester — Fill reservoir to mark on dipstick, and turn pump pulley backwards until all air is expelled from system. Recheck fluid level in pump.

All Others — Fill reservoir to proper level, and let oil remain undisturbed for at least two minutes. Start engine and run at idle speed for a short time, adding fluid as necessary to maintain proper level in pump. Turn wheels to left and right, contacting steering stops lightly. Check oil level and refill as necessary. Continue process as long as necessary to expell all air from system.

REMOVAL & INSTALLATION

POWER STEERING PUMP

Remove pulley nut, drive belt, and pulley. Disconnect and cap pressure and return hoses. Remove pump-to-bracket attaching bolts, and remove pump from vehicle. *NOTE — On some vehicles it may be necessary to remove rear pump bracket with pump; or bracket bolts must be loosened to remove pump. Do not loosen bracket bolts too much, as they may extend into water jacket.* To install, reverse removal procedure, and bleed system. See *Bleeding Hydraulic System*.

OVERHAUL

CAUTION — When clamping pump in vise, be careful not to exert excessive force on front hub of pump as bushing may become distorted.

Disassembly — 1) With pump removed from vehicle, and pulley removed from pump, remove key from pump shaft. Remove brackets from pump (if necessary), drain pump reservoir, and clean exterior of pump. Clamp pump assembly, with shaft pointing down, in a vise equipped with soft protective jaws. Be sure that vise grips pump at square boss and shaft housing. Remove pressure line union and "O" ring seal. Remove reservoir retaining stud, then tap lightly against filler tube, using a soft-faced hammer, to loosen reservoir on pump body. Remove reservoir from pump body, and remove and discard all "O" ring seals.

1965-74 SAGINAW VANE TYPE PUMPS (Cont.)

2) Using a dull punch, tap end cover retaining ring around until one end of ring is near hole in pump body. Insert punch in hole far enough to disengage ring from groove in pump bore and pry ring out of body. Tap end cover with soft-faced hammer to jar it loose, spring located under cover should push cover up. Remove pump body from vise.

3) Place pump in inverted position on flat surface, and tap end of drive shaft with soft-faced hammer to loosen pressure plate, rotor, and thrust plate assembly from body. Lift pump body off rotor assembly (flow control valve and spring should also slide out of bore). Remove and discard end plate and pressure plate "O" rings. Pry drive shaft oil seal from body using a screwdriver.

4) Inspect seal bore in housing for burrs, nicks, or score marks that would allow oil to by-pass outer seal surface. Lift pressure plate and cam ring from rotor, then remove rotor vanes. Clamp drive shaft in soft-jawed vise, with rotor and thrust plate facing up, and remove rotor lock ring from shaft, using care not to nick shaft or rotor. Slide rotor and thrust plate off shaft, and remove shaft from vise.

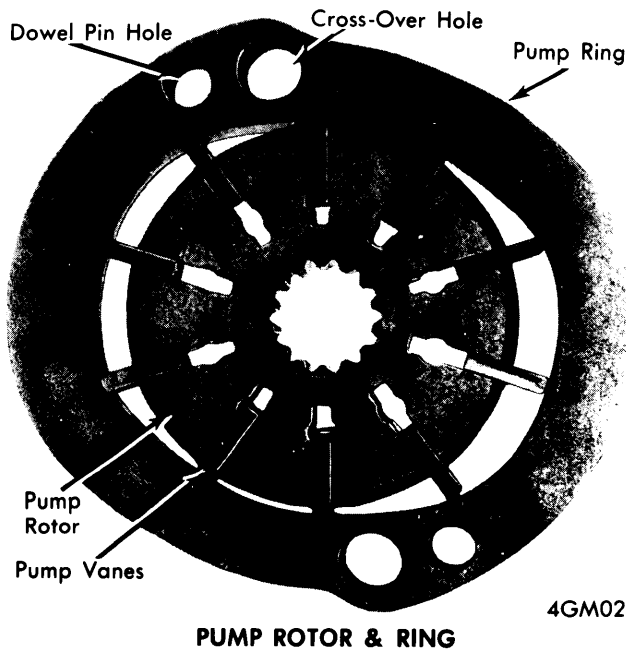

Cleaning & Inspection — Clean all pump parts in suitable solvent. **NOTE** — Do not immerse drive shaft seal in solvent. Replace any damaged or worn parts. Inspect flow control valve assembly for wear or damage. Inspect castings for cracks or other damage. Check all parts for score marks or burrs. **NOTE** — Cam ring is treated with "Lubrite" which leaves a dull gray-black finish on wear surface. Wavy grain appearance inside cam ring is normal.

Reassembly — **NOTE** — Lubricate all "O" rings and seal areas with power steering fluid.

1) Place pump body on flat surface and drive new shaft seal into bore, using a $\frac{7}{8}$ " or $\frac{15}{16}$ " socket, until seal bottoms on shoulder in bore. **CAUTION** — Excessive force will distort seal. Lubricate seal with power steering fluid, then clamp pump body in vise with shaft pointing down. Install end cover and pressure plate "O" rings in grooves in pump cavity.

2) With drive shaft clamped, splined end up, in a soft-jawed vise, install thrust plate on shaft with smooth, ported side up. Slide rotor over splines with counter bore of rotor facing down. Install rotor lock ring, making sure ring is seated in groove. Install two dowel pins in holes in pump cavity. Carefully insert drive shaft, rotor, and thrust plate assembly in pump cavity, indexing location holes with dowel pins.

3) Slide cam ring over rotor and onto dowel pins, with arrow on ring facing up. Install vanes in rotor slots with radius edge facing out towards cam ring inner surface. Position pressure plate on dowel pins. Place a $1\frac{1}{4}$ " socket in groove of pressure plate, and seat entire assembly on "O" ring in pump cavity by pressing down on socket with both thumbs.

4) Place spring in groove in pressure plate and position end cover lip edge up over spring. Press end cover down below retaining ring groove with thumb, and install retaining ring, making sure ring is seated in groove. Care should be taken to prevent cocking end cover in bore or distorting assembly.

5) Using a punch, tap retaining ring ends around in groove until opening is opposite flow control valve bore. This is necessary for maximum retention of retaining ring. Install new reservoir "O" ring, mounting stud "O" rings, and flow control valve "O" ring on pump body, then carefully position reservoir on pump body. Align mounting stud holes until studs can be started in threads.

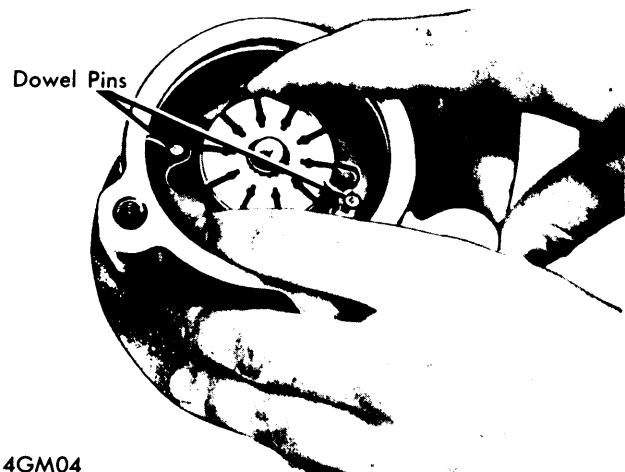

4GM04 INSTALLING DRIVE SHAFT ASSEMBLY

Power Steering Pumps

1965-74 SAGINAW VANE TYPE PUMPS (Cont.)

6) Using a soft-faced hammer, tap reservoir down on pump and install flow control valve spring and valve assembly. Install new "O" ring seal on pressure hose fitting. **CAUTION** — Be sure "O" ring is installed on upper groove. Install pressure hose fitting and tighten mounting studs. Tighten hose fitting and rear mounting stud(s). Remove pump assembly from vise, and install mounting brackets (if necessary) and drive shaft key.

TIGHTENING SPECIFICATIONS

Application	Ft. Lbs.
Pressure Hose Fitting	35
Bracket Mounting Bolts.....	35
Drive Pulley Nut	50
Flow Control Valve.....	4

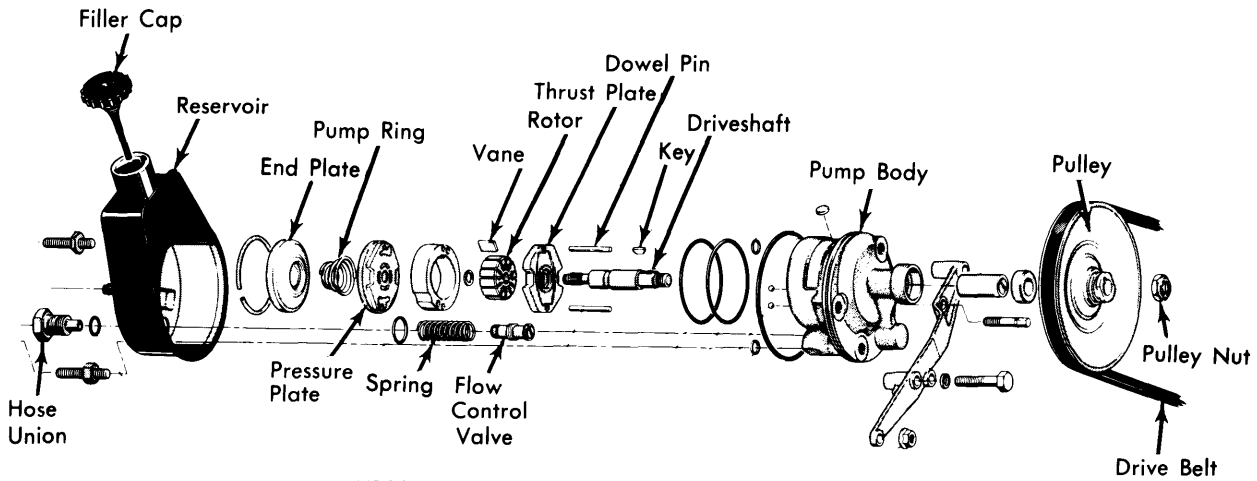

4JE03

SAGINAW PUMP ASSEMBLY