

## JEEP (SAGINAW) RECIRCULATING BALL

"J" Models (1965-74)  
 Jeepster (1969-73)  
 "DJ" Models (1972-73)  
 "CJ" Models (1972-74)  
 Wagoneer & Cherokee (1974)

NOTE — Some models use other units. See Jeep (Gemmer/Ross) Worm & Roller or Jeep (Gemmer/Ross) Cam & Lever in this Section.

### DESCRIPTION & OPERATION

Steering gear is a worm and recirculating ball type. Main components consist of worm shaft, ball nut, ball bearings, sector shaft, housing bushings and bearings. Ball nut is mounted on steering worm shaft and minimizes friction by transferring steering motion to free rolling ball bearings between ball nut and worm. As worm is turned, ball nut moves along worm shaft as a nut moves on a screw thread. Ball nut rack is in mesh with sector shaft gear and linear motion of ball nut on worm shaft is changed to sector shaft rotation.

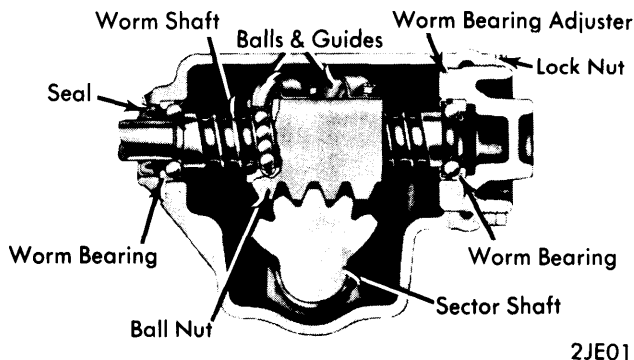

2JE01

### STEERING GEAR CROSS SECTION

#### LUBRICATION

Lubricant level of steering gear should be up to fill hole (see illustration). If lubricant level is abnormally low, check for leaks in steering gear. Use suitable steering gear lubricant (Jeep Part No. 94656), or equivalent. Steering gear lubricant capacity is 11 ounces.

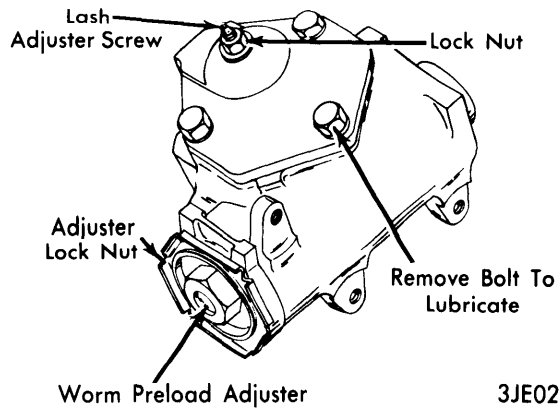

3JE02

### STEERING GEAR ADJUSTMENT POINTS & LUBRICATION

#### ADJUSTMENT

NOTE — Two adjustments can be made on steering gear which must be made carefully and in order given. Adjust worm bearing preload first and then over-center preload (ball nut and sector gear mesh). To perform adjustments, an INCH Lb. torque wrench must be used and steering linkage disconnected from gear.

#### WORM BEARING PRELOAD

Turn worm shaft to either extreme, left or right position, but do not hit travel stops, rotate worm back from stop about 1/2 turn. Loosen worm bearing lock nut and place INCH Lb. torque wrench on worm shaft. Measure, and adjust worm bearing preload with adjuster nut to specification. Measure preload with worm shaft within 1/2 turn of travel stops. Tighten adjuster lock nut to specification and recheck worm bearing preload.

#### OVER-CENTER PRELOAD

Turn steering gear from stop to stop counting total number of turns, then turn worm shaft back halfway to center sector. This places steering gear on high point or straight-ahead position. With torque wrench on pitman shaft, tighten lash adjuster screw until torque is less than 18 INCH Lbs. Torque should not exceed this value rotating gear through center position. Tighten adjuster lock nut as specified and recheck torque.

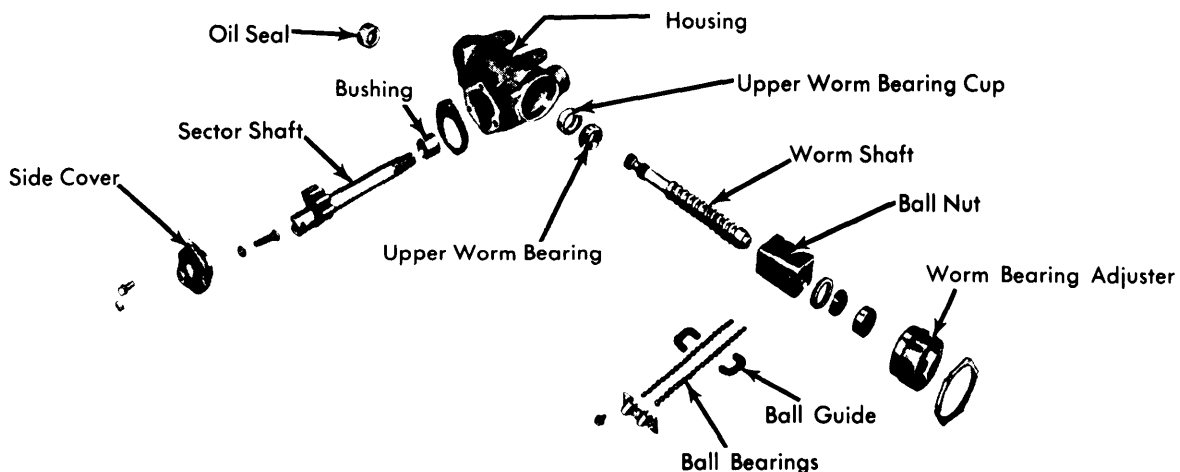

3JE03

### STEERING GEAR ASSEMBLY

# Manual Steering Gears

## JEEP (SAGINAW) RECIRCULATING BALL (Cont.)

### Adjustment Specifications

- Application** ① INCH Lbs.
- Worm Bearing Preload ( All Models) ..... 8  
 Over-Center Preload (All Models)..... ② 18
- ① - Gear only, pitman arm or steering linkage disconnected.  
 ② - Maximum.

### REMOVAL & INSTALLATION

*NOTE - Steering gear component fasteners are made of special quality materials. Replacement fasteners must be of same part number or equivalent. Torque all fasteners as specified.*

#### STEERING GEAR

- 1) Disconnect steering gear from lower steering shaft by removing bolt and nut attaching coupling to worm shaft. Disconnect steering linkage from pitman arm. Remove upper steering gear-to-frame bracket bolts and remove lower gear-to-frame bracket bolts, and remove steering gear.
- 2) To install steering gear, proceed as follows: Install coupling on worm shaft splines with point of coupling at mark on worm shaft (see illustration). Position gear against side frame rail and tighten bolts. Check steering column alignment and adjust if necessary. Connect steering linkage and tighten fasteners.

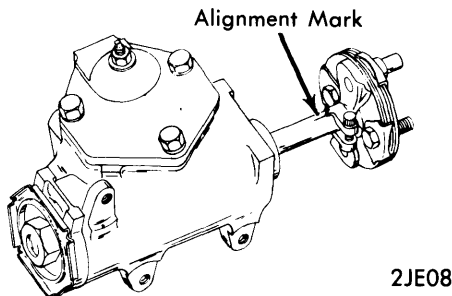

**FLEXIBLE COUPLING-TO-WORM SHAFT ALIGNMENT POINTS**

#### OVERHAUL

*NOTE - Clean entire outside surface of steering gear before disassembly to avoid contamination of worm shaft and ball nut assembly.*

#### DISASSEMBLY

- 1) Rotate wormshaft until gear is on high point of sector. Mark on shaft below double spline should be centered between top and bottom of shaft when looking at shaft from side cover side. Remove adjuster lock nut. Remove side cover bolts and turn lash adjuster screw clockwise to remove side cover. Remove adjuster screw and shim from sector shaft keeping shim with screw. Remove sector shaft from housing, tap lightly on splined end if necessary.
- 2) Remove worm adjuster lock nut, remove worm adjuster and lower worm bearing. If worm adjuster bearing needs replacing, pry bearing retainer out with a screwdriver. Remove

worm and ball nut assembly. *NOTE - Do not allow ball nut to run to either end of worm shaft or damage to ball guides may result.* Remove upper bearing from worm shaft. Remove oil seals from housing as necessary. Remove three screws retaining ball guide clamp. Catch ball bearings in a clean pan. Turn ball nut over and rotate wormshaft back and forth until bearings drop from nut, then remove ball nut from shaft.

#### CLEANING & INSPECTION

Wash all parts in clean solvent and wipe dry with a clean cloth. Inspect bearing cups in worm adjuster and in housing. Inspect worm shaft for pitting, grooving or other wear. Check pitman shaft bushings in housing and side cover. If bushings in housing are worn, replace them. If bushings in side cover are worn, replace side cover assembly. Inspect teeth of ball nut and sector gear for pitting or scoring. Check ball guides, ball bearings and clamp; if damaged, service with a new ball kit. Check fit of lash adjuster screw and shim in sector shaft.

#### COMPONENT SERVICE

**Bearing Cups -** To replace bearing cups in housing or worm adjuster, use suitable puller (C-3780). To install, use suitable installer tool (J-5755).

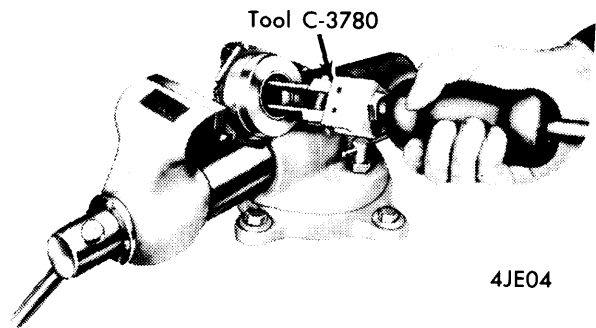

**WORM SHAFT BEARING CUP REMOVAL**

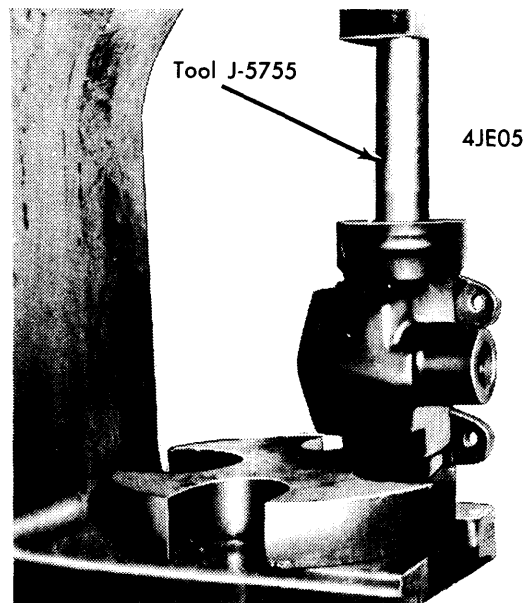

**PRESSING IN BEARING CUP**

## JEEP (SAGINAW) RECIRCULATING BALL (Cont.)

**Bushings** — To replace bushings in housing, use suitable bench press and remover-installer tool (J-1614).

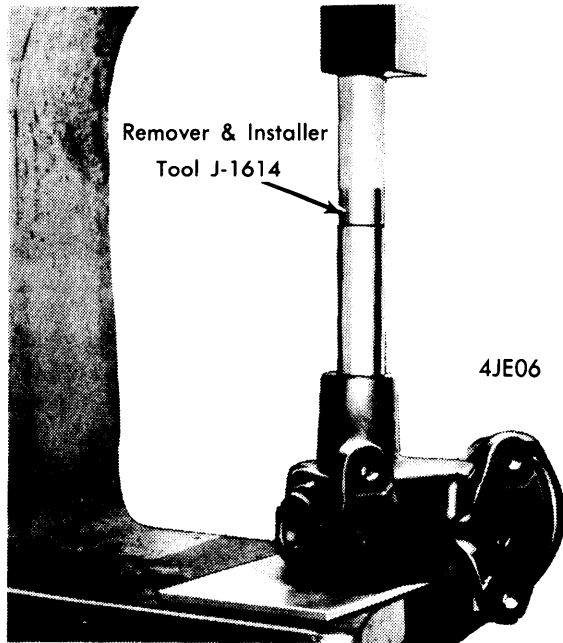

**SECTOR SHAFT BUSHING REMOVAL**

**Sector Adjuster End Play** — Lash adjuster screw must be free to turn and end play should not exceed .002". Adjust end play by changing shim thickness on adjuster screw. A shim kit is available.

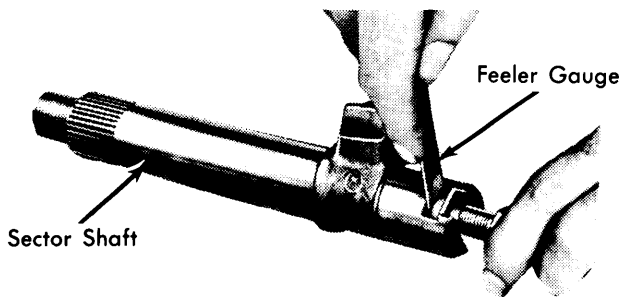

**CHECKING SECTOR LASH ADJUSTER END PLAY**

### REASSEMBLY

1) Lubricate all parts before reassembly using suitable steering gear lubricant. Position ball nut on worm so deep side of teeth will be toward side cover when shaft is installed in housing. Install 20 balls in each circuit rocking worm back and forth to aid installation. Use a punch if necessary to push balls into circuit. Install ball guides in ball nut and place 5 balls in each ball guide through guide holes, then install guide clamp. Rotate worm through its complete travel. Do not allow ball nut to hit end of travel, and note if worm rotates freely and balls are installed correctly.

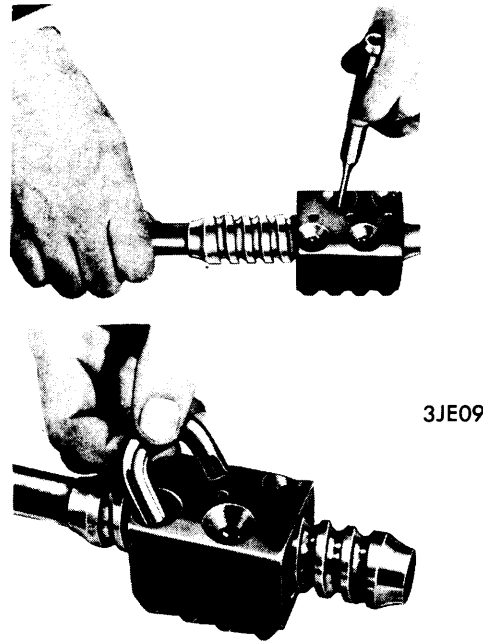

**FILLING BALL NUT CIRCUITS & INSTALLING BALL GUIDES**

2) Install bearing cups in worm adjuster or housing if removed. Install upper worm bearing on upper part of worm shaft and center ball nut on worm. Install assembly in housing with bearing seated in bearing cup. If bearing was removed from worm adjuster, install new bearing and retainer. Install adjuster in housing seating worm shaft in lower bearing, and install lock nut, but do not tighten. Turn worm until ball nut center tooth space is centered in opening of side cover.

3) Install sector shaft in housing, meshing center tooth of sector with center space on ball nut. Place gasket and side cover on housing and turn adjuster screw to bring cover down on housing. Leave lash adjuster screw loose. Tighten side cover bolts as specified and install lash adjuster screw lock nut loosely. To install sector shaft oil seal, use seal protector tool (J-5787) and seal installer (J-7171) to install seal over sector shaft. If worm shaft seal was removed from housing, install new seal using tool (J-7017). Fill steering gear with suitable steering gear lubricant (11 ounces) and perform adjustments as previously outlined.

### TIGHTENING SPECIFICATIONS

Application	Ft. Lbs.
Worm Adjuster Lock Nut.....	70-100
Sector Lash Adjuster Lock Nut.....	18-27
Pitman Arm-To-Sector Shaft Nut	
1973-74 Models.....	160-210
1972 Models.....	110-140
1969-71 Jeepster .....	120-160
1969-71 "J" Models .....	120-160
1965-68 "J" Models .....	100-125
Side Cover Bolts .....	25-35
Steering Gear Coupling Bolts .....	15-20
Steering Gear-To-Frame	
1969-71 Jeepster .....	42-52