

Manual Steering Gears

IHC (SAGINAW) RECIRCULATING BALL

International Harvester (1969-74)

NOTE — Some models use other units. See IHC (Gemmer/Ross) Worm & Roller or IHC (Gemmer/Ross) Cam & Lever in this Section.

DESCRIPTION & OPERATION

Steering gear is a worm shaft and recirculating ball type. Some gears have a horizontal sector shaft and others have a vertical sector shaft. Both types of gears are serviced in same manner and specifications for both gears are the same. Gear consists of a ball nut and worm shaft assembly in mesh with sector gear. As worm shaft is turned, ball nut moves along worm on precision finished helical grooves separated by ball bearings which roll within grooves.

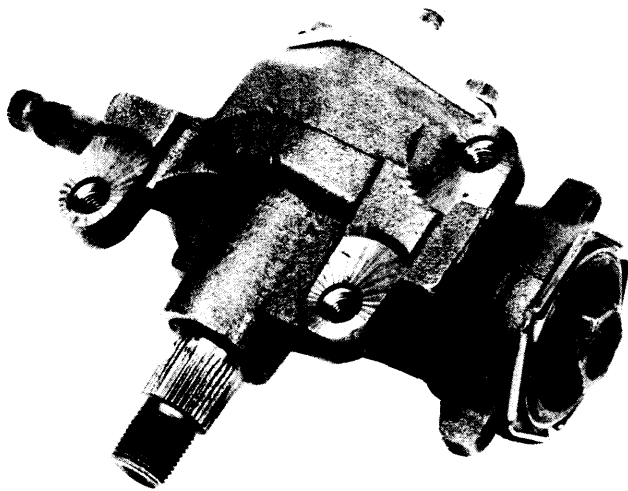

OIH01

HORIZONTAL SECTOR SHAFT STEERING GEAR

LUBRICATION

At overhaul, fill steering gear housing with 11 ounces of Lithium 12, Hydroxy Stearate E.P. grease. If necessary to add grease with gear in vehicle, inject grease through cover mounting bolt hole over worm shaft.

ADJUSTMENT

NOTE — Two adjustments can be made on steering gear. These adjustments must be made carefully and in order given. Adjust worm bearing preload first and then over-center preload (ball nut and sector gear mesh). Adjustments may be made in vehicle or on bench. If adjusting gear in vehicle, disconnect pitman arm from gear and disconnect flexible coupling. With linkage disconnected, do not turn gear hard against stops.

WORM BEARING PRELOAD

Loosen sector shaft lash adjuster. Tighten worm bearing adjuster until all end play has been removed, and tighten lock nut as specified. Turn worm shaft carefully to either stop and then

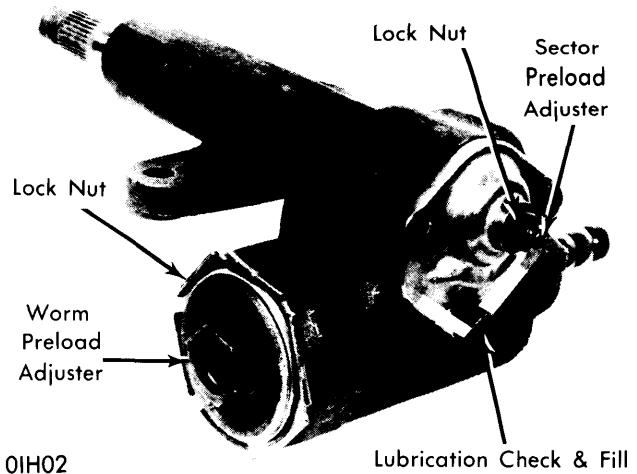

OIH02

VERTICAL SECTOR SHAFT STEERING GEAR

turn back about one turn. Use an INCH lb. torque wrench on worm shaft and measure torque required to keep shaft in motion. If necessary, readjust worm bearing adjuster and tighten lock nut.

OVER-CENTER PRELOAD

Turn worm shaft carefully from stop to stop counting total number of turns, then turn shaft back exactly half way to center position. Turn sector shaft lash adjuster screw to remove all lash between sector teeth and rack. Tighten lock nut. Use an INCH lb. torque wrench on worm shaft and measure torque required to turn gear through center position (see specifications). *NOTE — Highest reading on torque wrench should not occur outside $\pm 45^\circ$ from center. Readjust as necessary to obtain proper over-center preload on sector.*

Adjustment Specifications

Application	INCH Lbs.
Worm Shaft Bearing Preload.....	5-8
Over-Center Preload.....	9-18

REMOVAL & INSTALLATION

NOTE — Steering gear component fasteners are made of special quality materials. Replacement fasteners must be of same part number or equivalent. Torque all fasteners as specified.

STEERING GEAR

1) Position wheels straight-ahead, note mark on lower flexible coupling with gear worm shaft mark. Remove pitman arm from gear using suitable puller (SE-1050). Remove bolt and nut from lower flexible coupling clamp, and slide coupling up to disconnect from worm shaft. Remove steering gear mounting bolts and remove gear from vehicle.

IHC (SAGINAW) RECIRCULATING BALL (Cont.)

2) To install gear, place gear in chassis and tighten mounting bolts. Center worm shaft in travel range and match marks on coupling with those on gear worm shaft. Slide coupling into position and secure clamp bolt. Install pitman arm, lock washer and nut. Tighten all fasteners as specified.

OVERHAUL

NOTE — Clean entire outside surface of steering gear before disassembly to avoid contamination of worm shaft and ball nut assembly.

DISASSEMBLY

1) Loosen sector shaft adjuster lock nut and turn adjuster screw a few turns counterclockwise to remove gear mesh load. Loosen worm bearing adjuster lock nut and turn adjuster out a few turns. Place a pan under gear to catch lubricant and remove side cover bolts. Pull side cover and sector shaft from

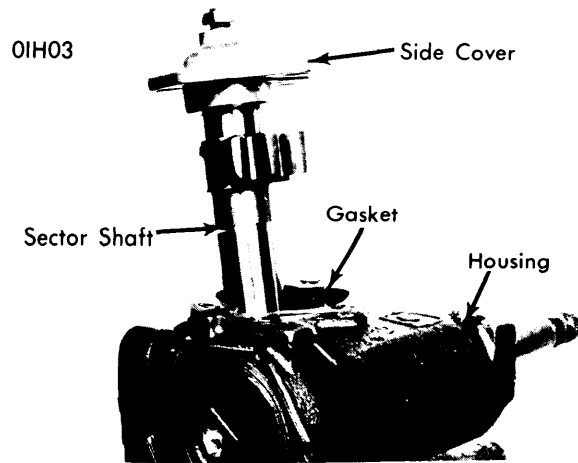

**SIDE COVER & SECTOR SHAFT ASSEMBLY
REMOVAL & INSTALLATION**

OIH04

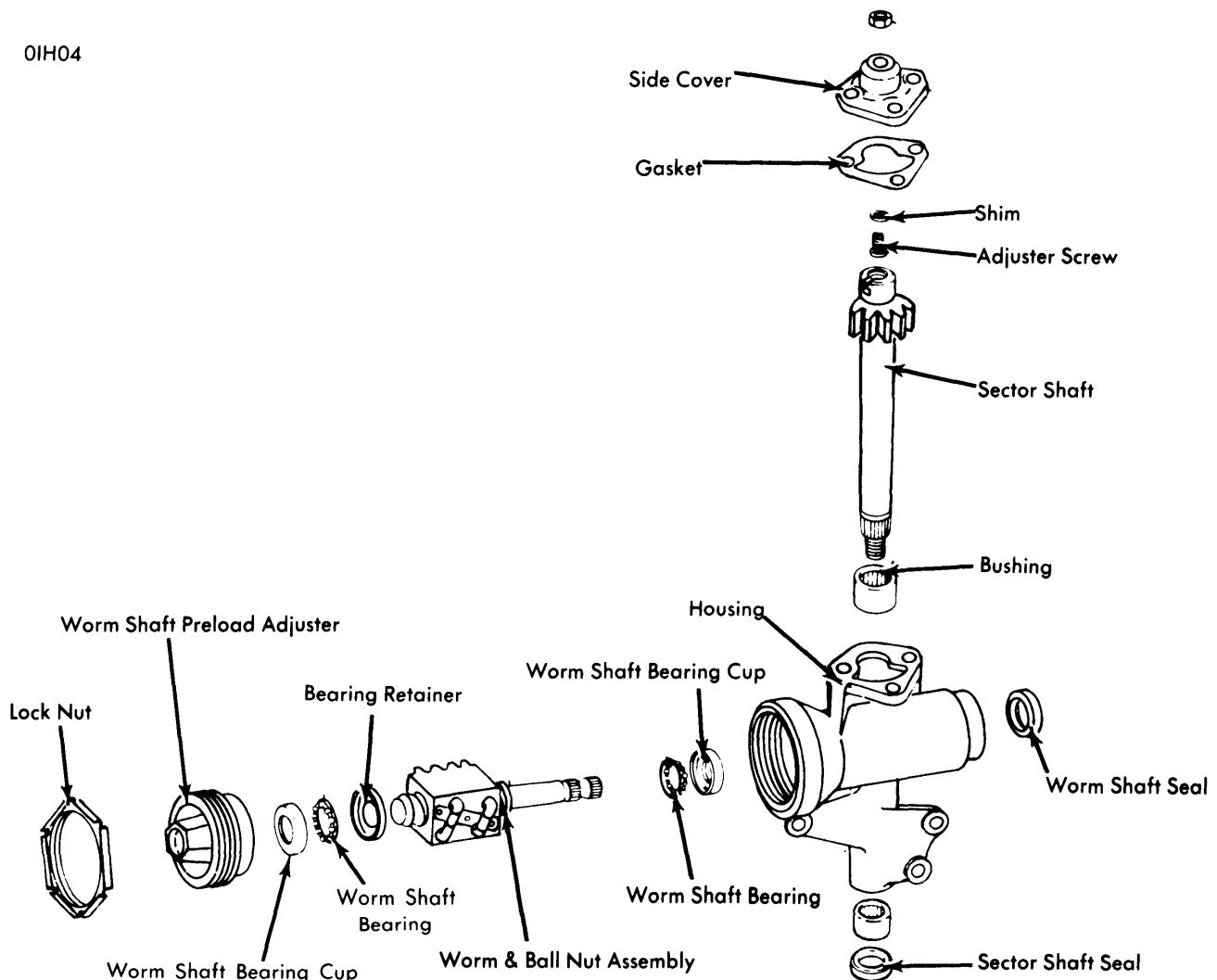

STEERING GEAR EXPLODED VIEW (TYPICAL)

Manual Steering Gears

IHC (SAGINAW) RECIRCULATING BALL (Cont.)

housing (see illustration). **NOTE** — If sector does not clear opening easily, turn worm shaft by hand until sector may be removed. Remove lock nut from adjuster screw and turn adjuster screw to remove side cover. Slide adjuster screw and shim out of sector slot.

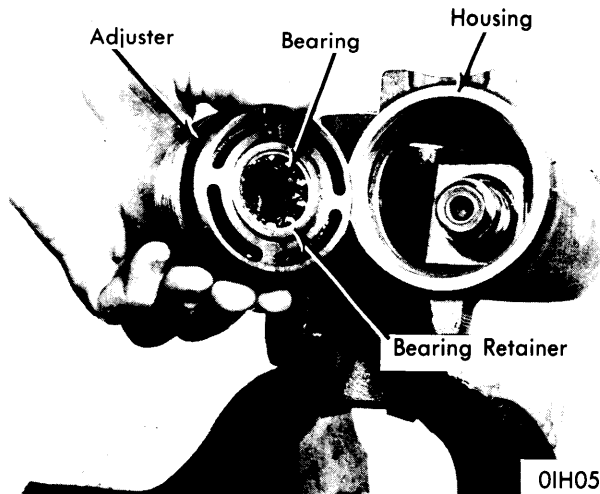

WORM SHAFT BEARING ADJUSTER ASSEMBLY

2) Remove worm adjuster lock nut, adjuster and lower bearing from housing. Carefully draw worm shaft and nut assembly from housing and remove upper bearing. **NOTE** — Do not allow ball nut to rotate down to either end of worm or damage to ball guides may result.

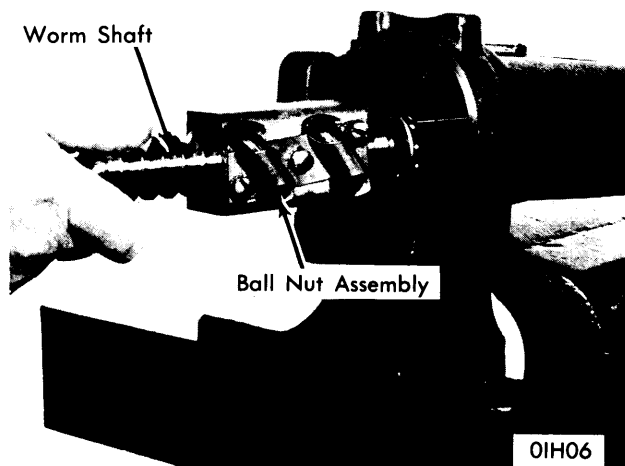

**WORM SHAFT & BALL NUT ASSEMBLY
REMOVAL & INSTALLATION**

CLEANING & INSPECTION

Wash all parts in clean solvent and dry with compressed air. Inspect bearings and bearing cups for signs of indentation. Any parts that show signs of wear should be replaced. Seals that are worn should be replaced. Inspect sector housing bushings and side cover bushing. If side cover bushing is worn, replace entire side cover assembly.

COMPONENT SERVICE

Sector Shaft Seal — Support housing and pry seal from housing with a screwdriver. If sector bushings are to be replaced, seal can be pushed out with bushings. To install seal, a socket may be used pressing on outer edge of seal. Press seal into bore until seal is flush with housing.

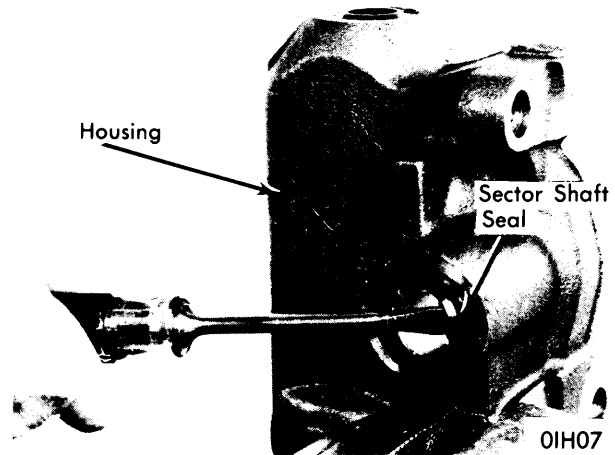

SECTOR SHAFT SEAL REMOVAL

Sector Shaft Bushings — Support housing in an arbor press. Use suitable adapter plate (SE-2066-3) and drift to remove bushings. With vertical sector type gears, upper bushing should be flush with housing. Lower bushing should be flush with bottom edge of seal bore recess. **NOTE** — Bushings are presized and require no reaming at time of installation.

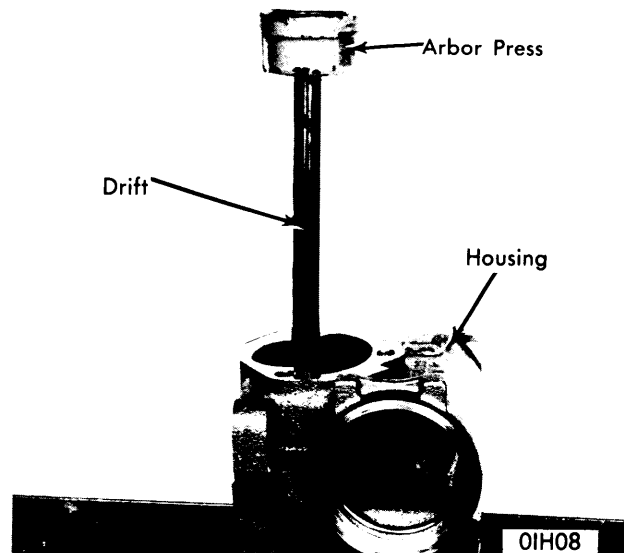

REMOVING SECTOR SHAFT BUSHING

Worm Shaft Seal — Support housing and pry seal from housing using a screwdriver. To install seal, use a socket pressing on outer edge of seal; seal should be installed flush with housing.

IHC (SAGINAW) RECIRCULATING BALL (Cont.)

Worm Shaft Bearing (In Housing) — Support housing and use a socket that is slightly smaller than seal bore, drive bearing cup out of housing. **CAUTION** — Do not allow cup to fall as damage may result. To install, turn housing over and place cup squarely in housing bore with socket of correct size. Drive cup in until it is seated against housing shoulder.

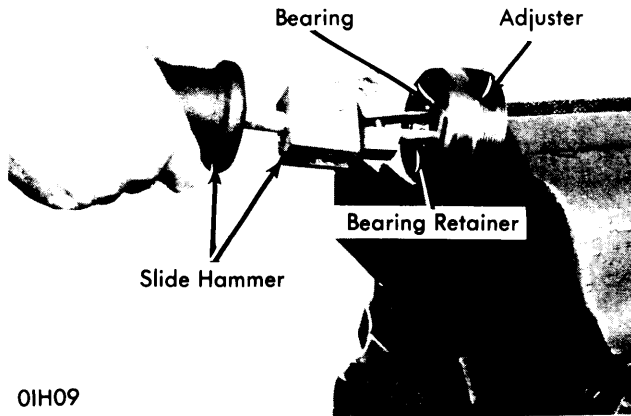

OIH09

REMOVING WORM SHAFT BEARING RETAINER & CUP

Worm Shaft Bearing (In Adjuster) — With adjuster clamped in a vise, use a suitable slide hammer (SE-1746), and pull retainer out of adjuster. Use same tool to remove bearing cup from adjuster. To install bearing cup, use suitable socket to drive cup squarely into adjuster. To install retainer, press on outer edge of retainer until it is flush with adjuster assembly.

Ball Nut Assembly — 1) **NOTE** — Disassembly of ball nut assembly is not necessary unless unit shows signs of wear, binding or tightness when rotated on worm under load. Remove guides from nut over a clean pan to catch balls. Invert nut and rotate worm to permit balls to drop from nut, and remove worm shaft from nut. Wash parts and inspect with a magnifying glass for wear. Check ball guide ends for damage.

2) To reassemble, hold ball nut level and insert worm shaft into nut. Align grooves in worm and nut by sighting through guide holes. Place balls in two groups of 25 balls each. Install balls in guide holes until circuit is filled from bottom of one guide hole to bottom of other. **NOTE** — Do not place all 25 balls in ball nut guide holes, fill only to bottom of guide holes. Remaining balls are placed in return guides. Each ball circuit must contain 25 balls. Install return guide, with remaining balls for one circuit, in ball nut. Repeat procedure for other circuit. Check assembly by rotating worm shaft to see that it moves freely.

REASSEMBLY

1) Apply steering gear lubricant to worm shaft bearings and seals, sector shaft bushings and seal, worm shaft grooves and ball nut. To prevent possible leakage of gear lubricant, coat threads of adjuster, side cover bolts and lash adjuster with a suitable nondrying, oil resistant sealing compound, such as Permatex No. 2 or equivalent.

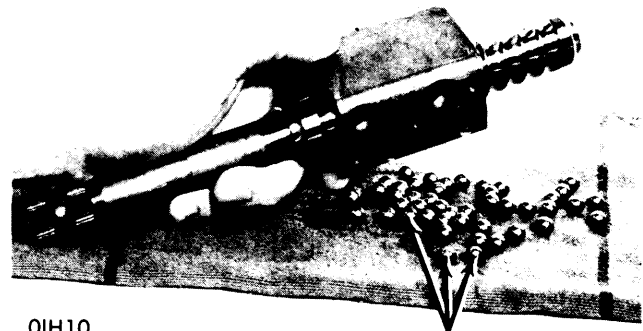
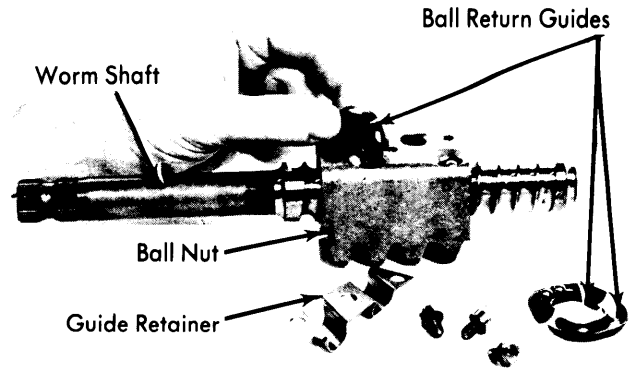

OIH10

WORM SHAFT & BALL NUT DISASSEMBLY

2) Wrap worm shaft serrations with tape to prevent cutting seal during shaft installation. With worm shaft seal, bearings and bearing cups installed, and ball nut on worm, install worm and nut assembly into housing. Feed end of shaft through upper ball bearing cup and seal. Thread adjuster into steering gear housing, tighten adjuster while rotating worm shaft to effectively seat bearings. Then loosen adjuster so no bearing preload exists and adjust worm bearing preload as outlined in Adjustments.

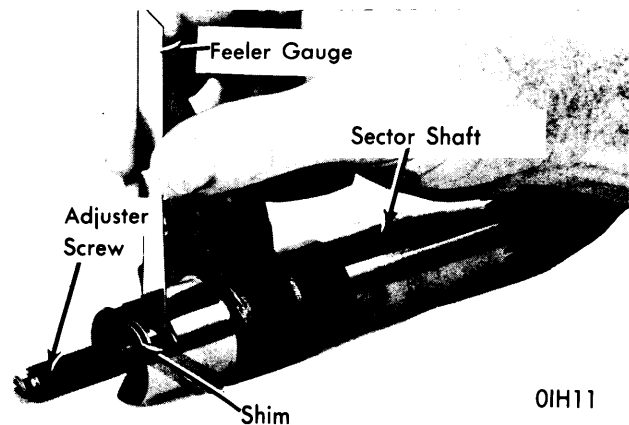

OIH11

CHECKING LASH ADJUSTER END CLEARANCE

Manual Steering Gears

IHC (SAGINAW) RECIRCULATING BALL (Cont.)

3) Before installing sector shaft, check lash adjuster end clearance (see illustration). Install lash adjuster screw with shim in sector shaft. Check end clearance with a feeler gauge, clearance should be .002" or less. If clearance is greater than .002", a shim kit is available with shims .063", .065", .067" and .069" thick. Install side cover on sector shaft. Rotate worm shaft to center ball nut, so center tooth of sector will enter center tooth space of nut.

4) Apply lubricant to housing through side cover opening. Install new gasket on side cover, and install side cover and sector shaft assembly in housing. *NOTE — Tape splines before installing shaft.* Install side cover bolts, make sure there is some lash between adjuster screw and side cover before tightening

bolts to specification. Install lash adjuster lock nut, but do not tighten. Adjust over-center preload as outlined in Adjustments.

TIGHTENING SPECIFICATIONS	
Application	Ft. Lbs.
Worm Bearing Adjuster Lock Nut.....	70-100
Side Cover Bolts.....	25-35
Sector Lash Screw Lock Nut.....	18-27
Pitman Arm Retaining Nut.....	125-150
Steering Gear Mounting Bolts.....	60-70
Coupling Clamp Bolt.....	30-35
Ball Return Guide Clamp Screws.....	2-6