

Steering Columns

11-27

1965-74 FORD MOTOR CO.

All Models (1965-74)

DESCRIPTION

Econoline and "P" models have steering columns with shift control rod mounted above steering column tube. "F" models and Bronco have steering columns with shift control rod within column tube. Directional signal switch and lever are only controls found mounted on or in column tube. There are no ignition switches or steering column locking devices. Columns are not collapsible.

NOTE — Information on models not listed was not available from manufacturer at time of publication.

REMOVAL & INSTALLATION

"F" MODELS (1971-74)

Removal — 1) Disconnect horn, turn signal, back-up light wires, and neutral start switch (if equipped). Remove steering wheel. Disconnect shift rods at column shift levers (if equipped). Disconnect flex coupling or coupling assembly at steering gear.

2) Remove screws retaining column to instrument panel. Remove bolts (in engine compartment) and screws (cab side) that retain column bracket to floor pan. Loosen clamp that retains column bracket to column. Lift column out of vehicle.

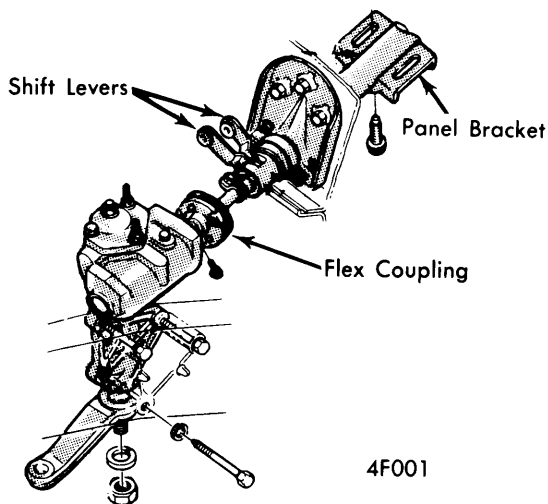

COLUMN INSTALLATION
1971-74 "F" MODELS 2-WD

Installation — 1) Position column in vehicle and install two screws retaining column to instrument panel. Align flex coupling or coupling assembly to steering gear and install retaining nuts. Install bolts (from engine compartment) and screws (cab side) to retain column bracket to floor pan.

2) Secure column to column bracket with column bracket clamp. Connect shift rods to shift levers (if equipped). Install steering wheel to steering shaft. The gap between lower edge of steering wheel hub and steering column should be .03-.06". Loosen column, if necessary, to obtain this specification. Connect horn, turn signal, back-up light wires, and neutral start switch (if equipped).

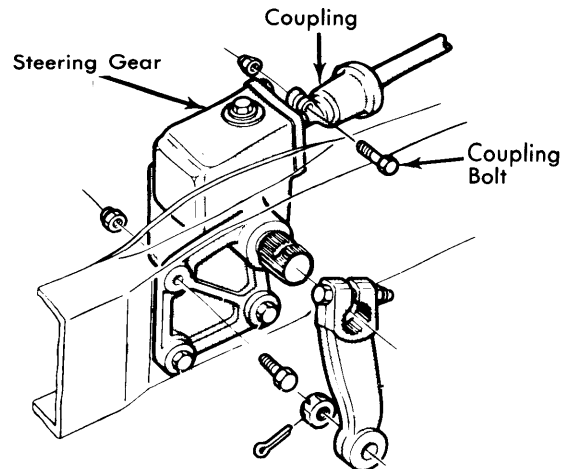

4F003

COLUMN INSTALLATION
1971-74 F-250 4-WD

BRONCO (1971-74)

Removal — 1) Disconnect horn, turn signal and back-up light wires. Remove screws retaining safety pad and horn ring. Remove both components. Remove steering wheel. Remove steering shaft-to-gear clamp retaining bolt and nut. Disconnect shift rods at column shift levers. Remove clamp retaining column to support bracket on dash panel.

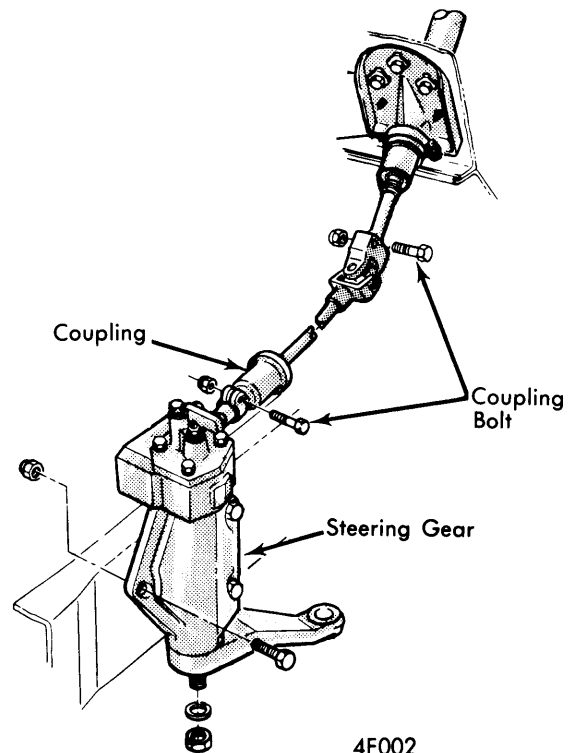

4F002

COLUMN INSTALLATION (TYPICAL)
1971-74 F-100 4-WD & BRONCO

Steering Columns

1965-74 FORD MOTOR CO. (Cont.)

2) Remove five nuts retaining column support bracket, rubber dust seal and plate assembly to dash panel. Remove four screws retaining trim cover and remove trim cover. Remove four column-to-upper support bracket retaining bolts. Remove four bolts retaining column upper support bracket to obtain clearance. Remove plate and dust seal assembly from dash panel and remove column assembly.

Installation - 1) Position column through opening in instrument and dash panels and align flex coupling to gear. Install clamp bolt and nut. Install back-up light switch on column. Position upper column support brackets and install four retaining bolts finger tight. Install and tighten four column bracket-to-support bracket bolts and nuts. Position rubber seal and plate assembly to dash panel. Position steering column support bracket to plate studs and install five nuts. Install column to the support bracket clamp with bolt and nut.

2) Connect shift rods to shift levers and install new retaining clips. Position trim cover to instrument panel and install four retaining screws. Install steering wheel on steering shaft. Gap between lower edge of steering wheel hub and steering column should be .03-.06". Loosen column, if necessary, to obtain this specification. Install horn ring and safety pad.

Connect back-up light, turn signal, and horn wires. Start engine and move vehicle to check shift operation.

"P" MODELS

Removal - 1) Disconnect horn, turn signal, and back-up wires. Remove steering wheel. Disconnect shift rods at column shift levers. Disconnect steering column to steering gear.

2) Remove two clamp bolts and nuts which retain column to instrument panel bracket. Remove eight screws attaching the four plates and gaskets to floor pan. Lift steering column out of vehicle.

Installation - Position column in vehicle and attach column to steering gear. Install eight screws to plates and gaskets at floor pan. Install two bolts and nuts that attach steering column to instrument panel bracket. Connect shift rods to column shift levers. Install steering wheel and connect horn, turn signal and back-up light wires.

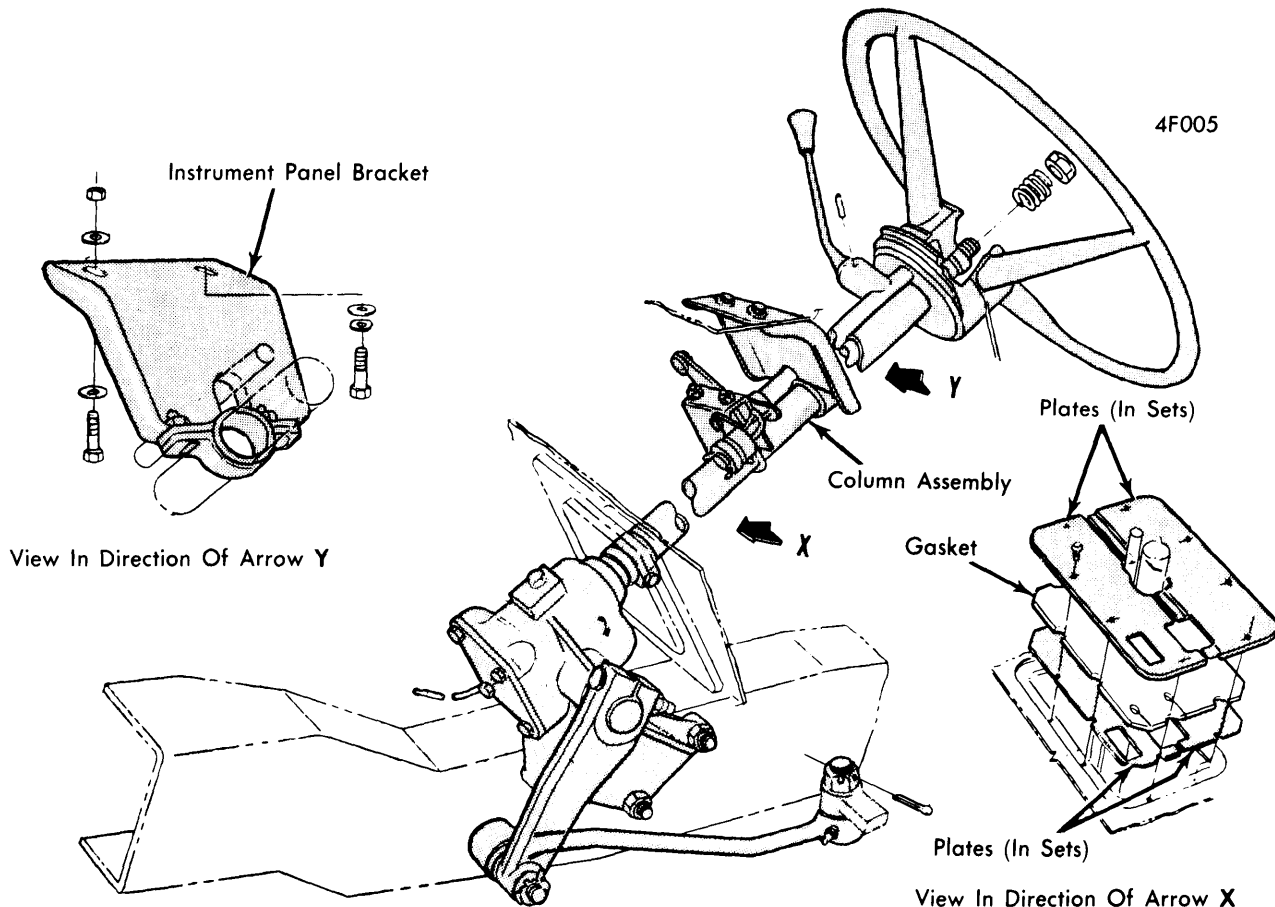

**COLUMN INSTALLATION
1971-74 "P" MODELS**

1965-74 FORD MOTOR CO. (Cont.)

ECONOLINE (1971-74)

Removal - 1) Disconnect horn, turn signal, and back-up light wires. Remove steering wheel and disconnect shift rods at column shift levers. Disconnect flex coupling to steering gear.

2) Remove clamp which retains column to support bracket on instrument panel. Remove five screws which retain plate assembly to floor pan. Remove bolt and nut from plate assembly clamp and lift column from vehicle.

Installation - 1) Position column in vehicle. Install column bracket retaining screws to support bracket on instrument panel. Align flex coupling to steering gear and install retaining nuts.

2) Install five screws retaining plate assembly to floor pan. Install bolt and nut into plate assembly clamp. Connect shift rods to column shift levers. Install steering wheel. Connect back-up light, turn signal, and horn wires.

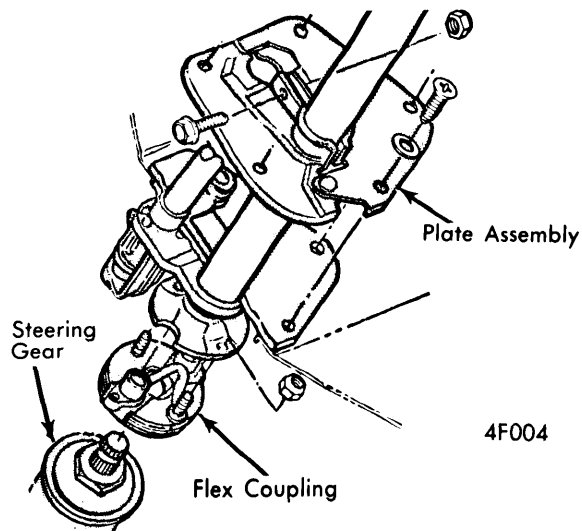

**COLUMN INSTALLATION
1971-74 ECONOLINE**