

Brakes

VOLVO

DL, GL, GLE, GLT, GLT Turbo,
DL & GL Diesel

DESCRIPTION

Volvo models may be equipped with Girling calipers on all 4 wheels or with Girling front calipers and ATE rear calipers. Service brakes are hydraulically-operated by a tandem master cylinder and vacuum power brake unit.

Master cylinder distributes hydraulic pressure to distribution/warning valve. Distribution/warning valve equally distributes hydraulic pressure to each circuit. One circuit is for lower front caliper pistons and right rear caliper. Other circuit is for upper front caliper pistons and left rear caliper.

If hydraulic pressure differs between circuits, dash-mounted light will glow. Each rear brake line has a pressure valve to prevent rear wheel lock-up. Parking brake is mechanically-operated on rear wheel mounted, internal brake shoes.

ADJUSTMENT

PEDAL HEIGHT

Brake pedal height should be equal to clutch pedal height. To adjust, loosen lock nut, remove cotter pin and turn push rod until pedal height is equal. Replace cotter pin and tighten lock nut. Pedal travel should be 5.7-6.5" (145-165 mm).

NOTE: Pedal travel can only be measured during brake bleeding operation. See Hydraulic System Bleeding article in this section.

STOP LIGHT SWITCH

1) Stop light switch is located under instrument panel, in front of brake pedal. To adjust, loosen retaining screws, and position switch so contact plunger just contacts pedal arm.

2) Measureable distance from switch body to pedal arm should be .08-.24" (2-6 mm). Tighten retaining screws.

PARKING BRAKE

NOTE: Adjust parking brake when full application stroke of brake lever exceeds 3 or 4 notches.

1) Remove center console rear ash tray, then working through ash tray hole, loosen parking brake cables adjusting screw until cables are slack.

2) Raise and support rear of vehicle, then remove wheels. Align hole in parking brake drum with starwheel adjuster.

3) Tighten starwheel until drum can just be rotated by hand, then back off adjuster until drum just rotates freely. Install rear wheels.

4) Tighten parking brake cable adjusting screw until parking brake is fully applied when lever is pulled 2 or 3 notches. Install ash tray and lower vehicle.

BRAKE WARNING LIGHTS

Brake Failure Light

1) This light will glow if pressure differential is exceeded or fluid level is low. Light will continue to glow until problem is corrected.

2) Check calipers, hydraulic lines, master cylinder, power brake unit and vacuum pump for defects and repair as needed.

Parking Brake Light

This light should glow when parking brake lever is pulled 1 notch, and go out when fully released (ignition on).

REMOVAL & INSTALLATION

DISC PADS

Removal

1) Raise and support vehicle. Remove tire and wheel. On Girling calipers, remove lock clip; then, remove 1 lock pin while holding damper spring in place. Remove springs and other lock pin.

2) On ATE calipers, drive out upper guide pin, and remove tensioning spring. Drive out lower guide pin. Remove disc pads from caliper with pad extractor tool (2917).

3) Replace pads in sets if lining thickness is less than 1/8" (3 mm). If pads are to be reinstalled, mark for reference.

Installation

1) Siphon small amount of fluid from master cylinder reservoir. Seat pistons in caliper bore with piston tool (2809).

2) On ATE rear calipers, check piston position by installing template (SV02919). Piston recess should incline 20° in relation to lower guide area on caliper. If distance from one recess to the other (*Measurement "A" in Fig. 1*) exceeds .04" (1 mm), adjust position.

Fig. 1: Checking ATE Rear Caliper Piston Angle

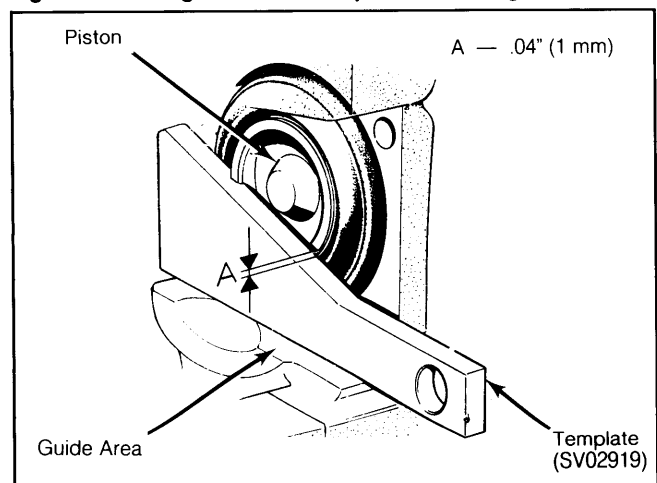

Piston recess should incline 20° in relation to lower guide area on caliper.

VOLVO (Cont.)

3) Install new pads, install intermediate plates (if equipped) or damper washers (if equipped) in original positions. On Girling calipers, install one lock pin; then, install damper springs and other lock pin.

4) Install new lock clips on pins. On ATE calipers, tap 1 guide pin into position, and install new tensioning spring. Install other guide pin while holding tensioning spring in position.

NOTE: Install damper washers with small contact face toward pad. DO NOT install intermediate plates in calipers equipped with damper washers.

5) After installation, depress brake pedal several times to seat pads against rotor. Ensure proper operation of brakes, install wheel and lower vehicle.

CALIPER ASSEMBLY

Removal

1) Raise and support vehicle, and remove wheel. Disconnect brake line connections at caliper, and cap lines to prevent entry of foreign matter.

2) Remove caliper mounting bolts and lift caliper from mounting bracket.

Installation

1) Position caliper assembly on mounting bracket, and install attaching bolts. After installing bolts, check clearance between disc pads and rotor on both sides of rotor.

2) Maximum deviation between sides should not exceed .004" (.10 mm) on front calipers or .010" (.25 mm) on rear calipers.

3) If clearance is not within specifications, correct by adding shims to caliper. Connect hydraulic lines and bleed hydraulic system.

DISC BRAKE ROTOR

Removal

1) With caliper assembly removed, mount a dial indicator and check rotor runout. Runout must not exceed .004" (.10 mm).

2) Measure rotor thickness through one revolution. Thickness variance must not exceed .0008" (.02 mm). Unscrew rotor lock bolts and pull rotor from hub.

Installation

To install, reverse removal procedure.

PARKING BRAKE SHOES

Removal

1) Remove center console rear ash tray and loosen parking brake cable adjusting nut until cables are slack. Raise and support rear of vehicle and remove wheels.

2) Remove caliper (without disconnecting hydraulic line) and support out of way, then remove rotor. Remove brake shoe return springs and lift off shoes and adjuster.

Installation

1) Reverse removal procedure and note the following: Replace brake drum (rotor) if out-of-round more than .008" (.2 mm).

2) Apply a thin coat of heat-resistant graphite grease to brake shoe sliding surfaces and to adjusting starwheel. After installation, adjust parking brake.

Fig. 2: Exploded View of Parking Brake Assembly

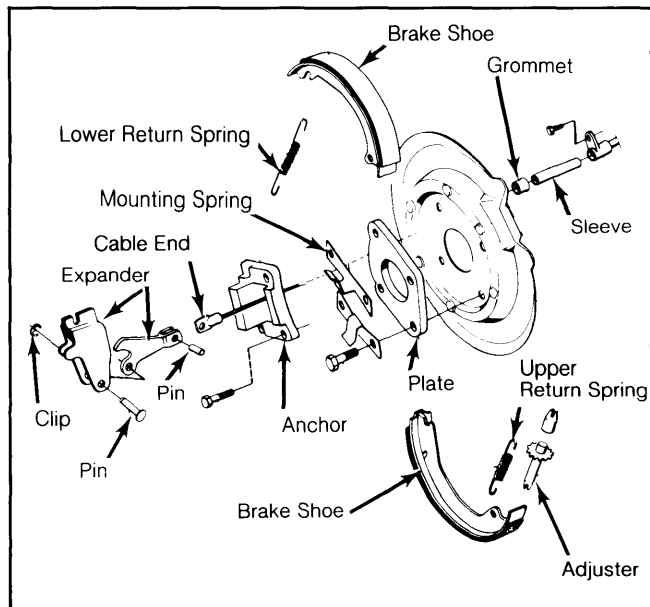

MASTER CYLINDER

Removal

Disconnect hydraulic lines at master cylinder and cap openings to prevent entry of foreign matter. Remove cylinder attaching nuts, and remove cylinder assembly from vehicle.

Installation

To install, reverse removal procedure. Bleed hydraulic system.

POWER BRAKE UNIT

Removal

1) With master cylinder removed, disconnect vacuum hose at power unit. From inside vehicle, disconnect push rod link at brake pedal and remove clutch pedal stop bracket.

2) Remove power unit attaching nuts at firewall. Tilt power unit slightly forward and remove lock nut and yoke. Remove power unit from engine compartment.

Installation

To install, reverse removal procedure and note the following: Install new gasket between power unit and firewall. Discarding sealing putty (if equipped). Install vacuum hose connector face down. Bleed hydraulic system.

Check Valve Replacement

Remove vacuum hose clamps at check valve, and remove check valve from power brake unit. When installing check valve into power brake unit, install valve with arrow on valve housing pointing toward intake manifold.

Filter Replacement

Remove power brake unit from vehicle. Remove rubber dust boot, and filter retainer washer. Withdraw silencer and filter from end of booster. To install, reverse removal procedure, making sure slots in filter and silencer are 180° apart.

Brakes

VOLVO (Cont.)

VACUUM PUMP

Removal & Installation

Disconnect hoses at vacuum pump, and remove mounting bolts and pump. Clean mating surfaces to remove gasket material, and install new gasket. Reverse removal procedure to complete installation.

OVERHAUL

BRAKE CALIPER

Disassembly

1) With caliper removed from vehicle, remove disc pads, piston dust covers, and retaining clips.

Fig. 3: Girling Front Caliper Assembly

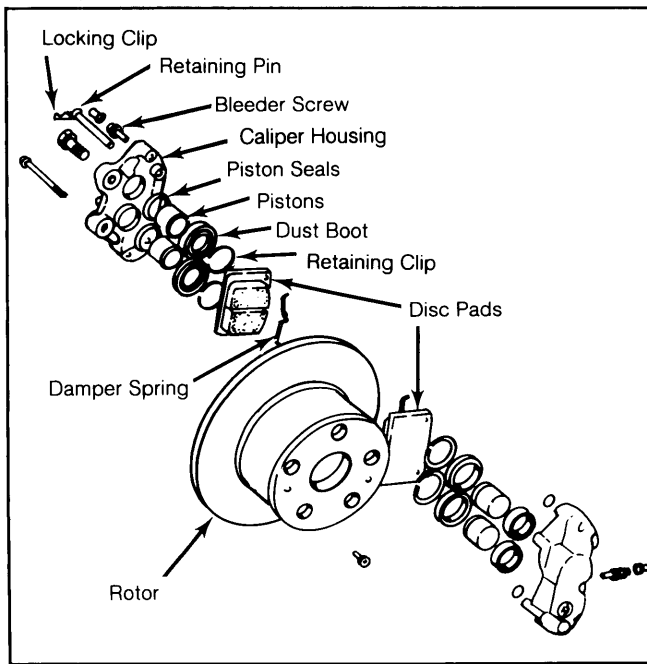
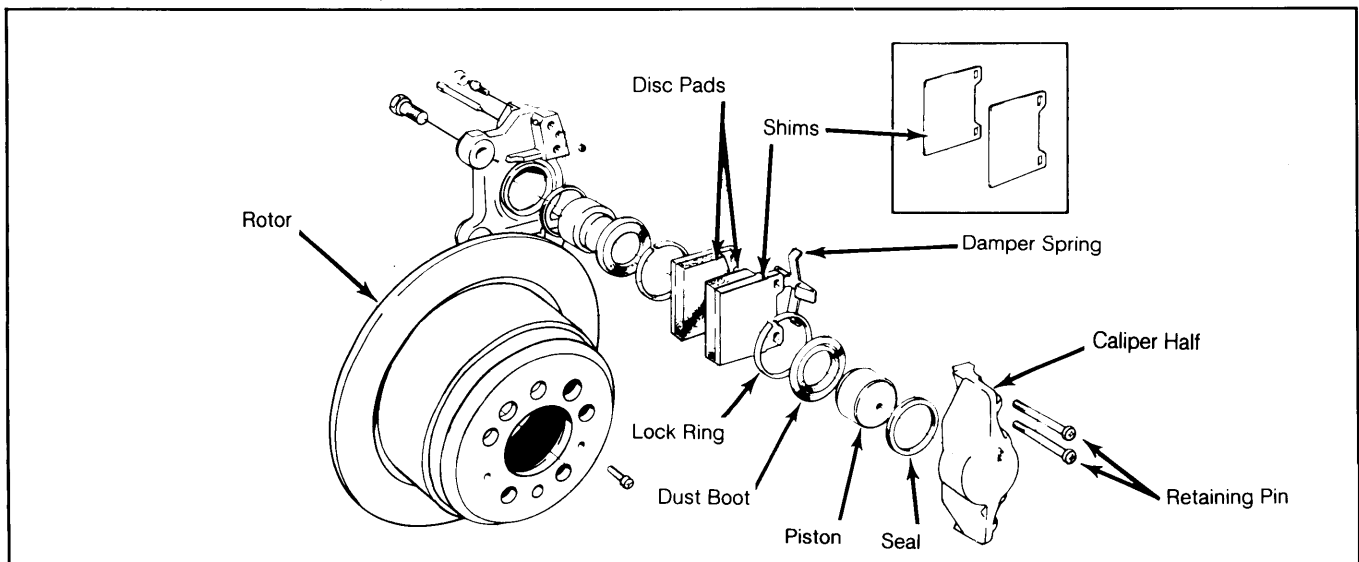
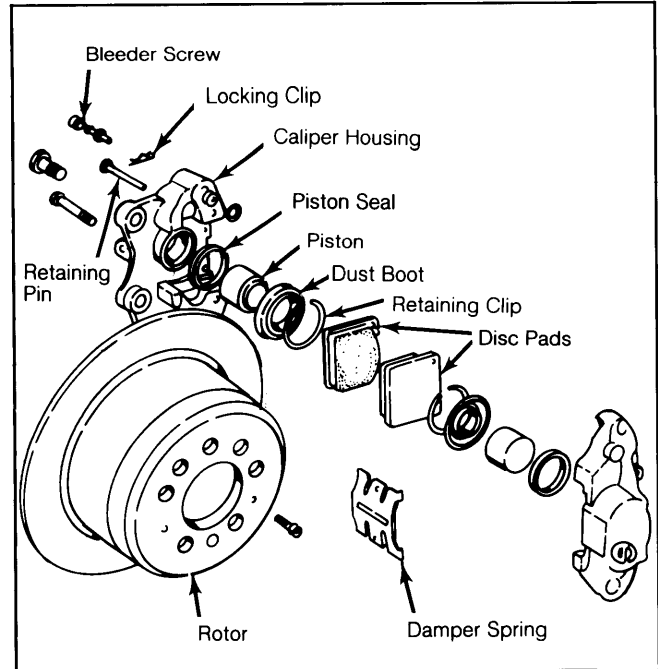

Fig. 4: ATE Rear Caliper Assembly



Replace rubber seals and dust covers if caliper is disassembled.

Fig. 5: Girling Rear Caliper Assembly



2) Insert wooden block into caliper housing and apply compressed air at fluid inlet ports to force pistons out of caliper.

3) Remove piston seals from cylinder bore with blunt tool without damaging cylinder bore. Open bleeder Screw.

NOTE: DO NOT separate caliper halves.

Cleaning & Inspection

Clean all parts in brake fluid or alcohol. Inspect cylinder bores for scoring, rust, or corrosion; replace if defective. Replace rubber seals and dust covers during overhaul.

VOLVO (Cont.)

Reassembly

1) Coat all parts with clean brake fluid, and install new piston seals in cylinder bores. Carefully install pistons into cylinder bores.

2) Check piston position on ATE rear brake calipers. Install rubber dust boots and retaining clips. Close bleeder screw and install disc pads.

MASTER CYLINDER

Disassembly

1) Remove master cylinder from vehicle, and clamp mounting flange in a vise. Remove reservoir from cylinder, and remove rubber sealing rings.

2) Remove piston stop screw, and remove retainer ring from end of cylinder bore. Remove pistons from cylinder bore.

Cleaning & Inspection

Wash all parts in clean brake fluid or alcohol, and blow dry with compressed air. Inspect cylinder bore for scratches, rust, or corrosion. Replace if defective. Replace both pistons with connector sleeve as an assembly.

Fig. 6: Master Cylinder Assembly

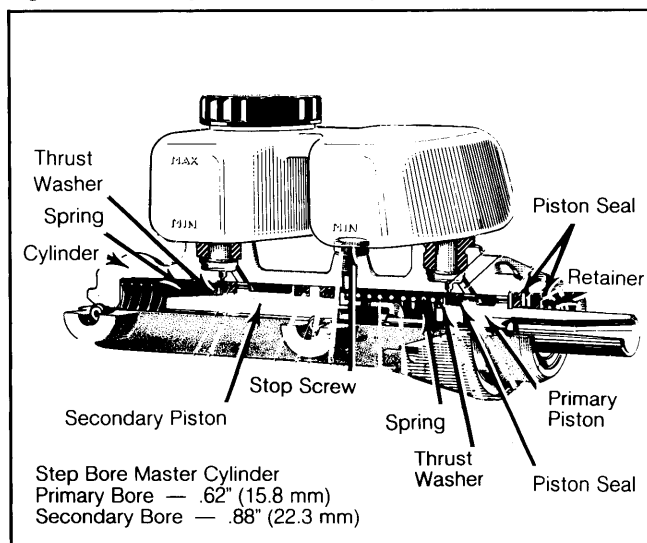

Do not hone master cylinder.

DISC BRAKE ROTOR SPECIFICATIONS

Application	Disc Diameter In. (mm)	Lateral Runout In. (mm)	Parallelism In. (mm)	Original Thickness In. (mm)	Min. Refinish Thickness In. (mm)	Discard Thickness In. (mm)
DL & GL, DL & GL Diesel004 (.10)	.0008 (.02)	.563 (14.3)	.557 ¹ (14.1)
				.378 (9.6)	.331 (8.4)
GLE, GLT & GLT Turbo004 (.10)	.0008 (.02)	.945 (24.0)	.990 ¹ (22.8)
				.378 (9.6)	.331 (8.4)

¹ — Minimum refinish thickness is stamped on all rotors. Adhere to stamped specifications.

Reassembly

1) Lubricate all parts with clean brake fluid prior to reassembly. Position washer, seal, and back-up ring on secondary piston.

2) Install spring thrust washer on piston, and install piston assembly into cylinder bore. Install washer, seal, and back-up ring on primary piston.

3) Install spring, with plate and sleeve on piston; then install piston assembly into cylinder bore.

4) Push piston into cylinder bore, and install piston stop screw. Install reservoir sealing rings, and install reservoir.

VACUUM PUMP

Disassembly

1) Place pump in soft-jawed vise. Scribe an index mark between valve housing and cover. Remove valve housing. Remove diaphragm, washers, and spring from pump.

2) Turn pump over. Remove bottom cover. Remove actuating lever pin. Slide out pump lever, pump rod, and nylon bushing.

Reassembly

1) Place bushing on pump rod. Put rod in pump housing. Fit lever and pin. Install bottom cover and gasket.

2) Place washer and "O" ring on diaphragm screw. Lightly coat end of screw with thread locking compound.

3) Install diaphragm assembly. Insert valve housing and align with index mark. Fit valves and seals. Make sure domed side of disc faces diaphragm. Install valve housing cover with spring and gasket.

TIGHTENING SPECIFICATIONS

Application	Ft. Lbs. (N.m)
Front Caliper Mounting Bolts	65-72 (88-98)
Rear Caliper Mounting Bolts	38-46 (52-63)