

SAAB 900 & 900 TURBO

DESCRIPTION

Service brake system is hydraulically-operated by a tandem master cylinder and vacuum power brake unit acting on 4-wheel disc brakes. Front calipers are sliding-yoke Girling calipers. Rear brakes are fixed-yoke ATE calipers.

Master cylinder contains level sensor, which illuminates a warning lamp on instrument panel if fluid level becomes low. Brake circuit is double-diagonal system (right front, left rear/left front, right rear). Parking brake is mechanically-operated on FRONT brake caliper assemblies.

ADJUSTMENT

PARKING BRAKE

- 1) Before adjusting cable, apply brake lever several times to stretch cables.
- 2) Rotate cable adjusting nuts located at rear of parking brake lever under plastic cover until distance between lever on front caliper and yoke is .019" (.5 mm).
- 3) With engine switched off, pump brake pedal repeatedly until foot brake starts to operate. Pull parking brake lever up 5 notches.
- 4) Continue to pump brake pedal until parking brake operates after being pulled up an additional 2-4 notches.

NOTE: Parking brake cables are crossed. To adjust left parking brake mechanism (cable), right adjusting nut must be rotated and vice versa.

BRAKE WARNING LIGHT

- 1) Brake warning lights are mounted on instrument panel. Parking brake light should glow when parking brake lever is pulled 1 notch (ignition on) and go off when lever is fully released.
- 2) To check lever indicator circuit, raise master cylinder filler cap. Warning light should glow. If not, check bulb, circuit connections and sensor.

REMOVAL & INSTALLATION

DISC BRAKE PADS

Removal (Front)

- 1) Raise and support vehicle. Remove tire and wheel. Rotate disc so that 1 of the recesses in the edge of disc is in line with brake pads.
- 2) Remove damper spring, pin retaining clip and pad retaining pin. If retaining pin is difficult to remove, use tapping out tool (83 90 270) and removal tool (89 96 175). Remove brake pads.

Installation

- 1) Rotate direct piston with brake piston wrench (89 96 043) at the same time brake piston is pressed into cylinder. If necessary, first siphon off 1/2 brake fluid from master cylinder to prevent overflow.
- 2) Check that piston movement has not moved dust cover. Check that yoke moves easily in groove in brake housing.
- 3) Fit the new pads together with "U" pin retaining clip and damper spring. To complete installation, reverse removal procedure and adjust parking brake.

Removal (Rear)

- 1) Raise and support vehicle. Remove tire and wheel. Tap out brake pad retaining pins using a .11" (2.8 mm) drift.
- 2) Remove retaining spring. Remove brake pads. If required, use extractor (89 95 043).

Installation

- 1) Use handle of brake piston key (89 96 043) and push pistons back far enough to install pads. Be careful not to overflow master cylinder.
- 2) Fit pad retaining pins and pin retaining clip. To complete installation, reverse removal procedure.

NOTE: Girling caliper brake pads are not interchangeable. Outer pads are identified by "V" notch.

DISC BRAKE CALIPER

Removal

- 1) Raise and support vehicle and remove wheels and tires. Remove brake pads. On front wheel calipers, disconnect parking brake cable from lever on caliper.
- 2) On all wheels, disconnect hydraulic line from caliper, plug lines to prevent entry of dirt and loss of fluid. Remove caliper attaching bolts and lift off caliper.

Installation

To install, reverse removal procedure and note the following: Tighten all attaching bolts, bleed hydraulic system and adjust parking brake cables.

DISC BRAKE ROTOR

Removal

Remove brake pads and caliper, suspending caliper out of way. DO NOT allow caliper to hang from hydraulic line. Remove retaining screws and remove brake rotor.

Installation

To install, reverse removal procedure. Tighten all nuts and bolts and adjust parking brake if necessary.

MASTER CYLINDER

Removal

- 1) Disconnect electrical lead to warning switch on master cylinder. Disconnect clutch master cylinder hose from fluid reservoir, then plug reservoir nipple to prevent loss of fluid.
- 2) Disconnect hydraulic lines from master cylinder. Remove master cylinder-to-power brake unit attaching nuts and lift off master cylinder.

Installation

To install, reverse removal procedure and bleed hydraulic system.

POWER BRAKE BOOSTER

Removal

- 1) Remove steering column bearing cover, ash tray and safety padding screw from inside vehicle. Remove safety padding screws from inside engine compartment.
- 2) Disconnect all electrical leads, hydraulic and vacuum lines from master cylinder and power brake unit. Remove cotter pin from brake pedal push rod.
- 3) Remove attaching nuts and lift off master cylinder and power brake unit as an assembly.

Brakes

SAAB 900 & 900 TURBO (Cont.)

Installation

To install, reverse removal procedure and bleed hydraulic system.

Check Valve Replacement

Remove vacuum hose clamps at check valve and remove check valve from power unit. To install, reverse removal procedure.

Filter Replacement

1) Remove power brake unit from vehicle. Remove rubber dust boot and filter retainer. Withdraw silencer and filter from end of booster.

2) To install, cut a slit in filter and slip over push rod. Reverse removal procedure and ensure slots in filter and silencer are 180° apart.

OVERHAUL

CALIPER ASSEMBLY

Disassembly (Girling Type)

1) With caliper removed from vehicle, mount assembly in a soft jawed vise. Remove parking brake return spring. Separate yoke from caliper assembly.

2) Remove spring and parking brake lever from yoke. Remove retaining ring and dust boot, then using compressed air, force out indirect piston assembly from caliper.

3) Press direct piston push rod and remove piston from caliper. Remove "O" rings and seal rings from caliper bore and pistons.

Fig. 1: Exploded View of Girling Caliper

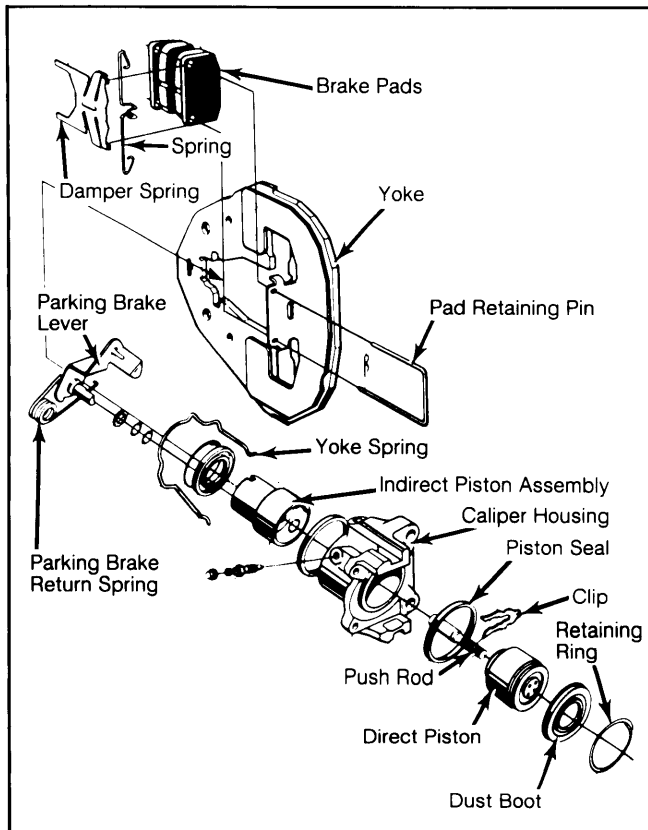

Ensure recess in anchor plate comes immediately over spring in piston.

Cleaning & Inspection

1) Wash all parts, except indirect piston assembly, in clean brake fluid and dry with a lint-free cloth.

2) Inspect all parts for corrosion, damage or wear. Replace defective parts. Replace all rubber parts during overhaul.

NOTE: Indirect piston assembly must be wiped clean only. DO NOT use any type of solvent or brake fluid.

Reassembly

1) Replace any worn, damaged or corroded parts. On indirect piston, replace "O" ring on push rod and "O" ring retainer at parking brake lever. Lubricate cylinder bore with brake fluid and fit new piston seals.

2) Lubricate aperture for parking brake lever with parking brake mechanism grease (89 94 782). Fit anchor plate to push rod and push push rod into hole in indirect piston.

3) Ensure recess in anchor plate comes immediately over spring in piston. Lubricate indirect piston and insert in caliper housing so recess for yoke is directly in line with groove in caliper housing.

4) In the same manner push the direct piston into cylinder and using brake piston key (89 96 043), screw together piston and push rod.

5) Screw and push in the 2 pistons until the edges of dust cover grooves are flush with caliper. Fit new dust covers and retaining rings.

6) Install yoke spring and parking brake lever to yoke. Brush Castrol-45 brake yoke grease (30 08 612) on yoke sliding surfaces. Apply grease to seating surface of pad retaining disc in housing.

7) Align yoke guide edges with grooves in brake housing. Lift the parking brake lever and fit end of axle pin into hole in indirect piston. Install parking lever return spring.

8) Check clearance between sliding surface of yoke and brake housing. No clearance is allowed on bleeder screw side. Opposite side must have .006-.012" (.15-.30 mm) clearance. See Fig. 2.

Fig. 2: Girling Caliper Clearance Measuring Points

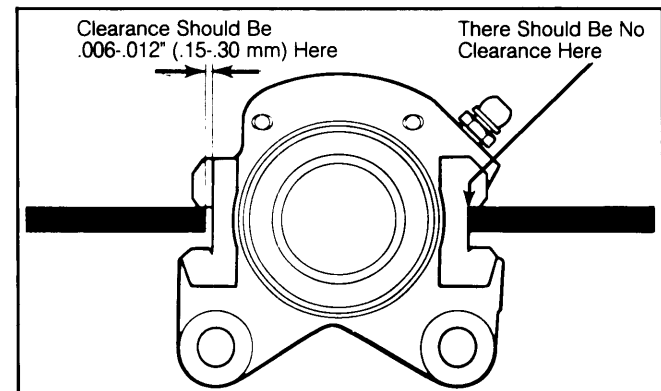

Align yoke guide edges with grooves in brake housing.

Disassembly (ATE Type)

1) With caliper and pads removed, clean outer portion of caliper. Remove dust covers and retaining rings.

SAAB 900 & 900 TURBO (Cont.)

2) Insert wooden block between pistons and carefully apply compressed air to fluid inlet port to force pistons out of cylinder bores.

3) Remove piston seals from cylinder bores without damaging bores. Remove bleeder screw.

NOTE: DO NOT separate caliper halves.

Fig. 3: Exploded View of ATE Caliper

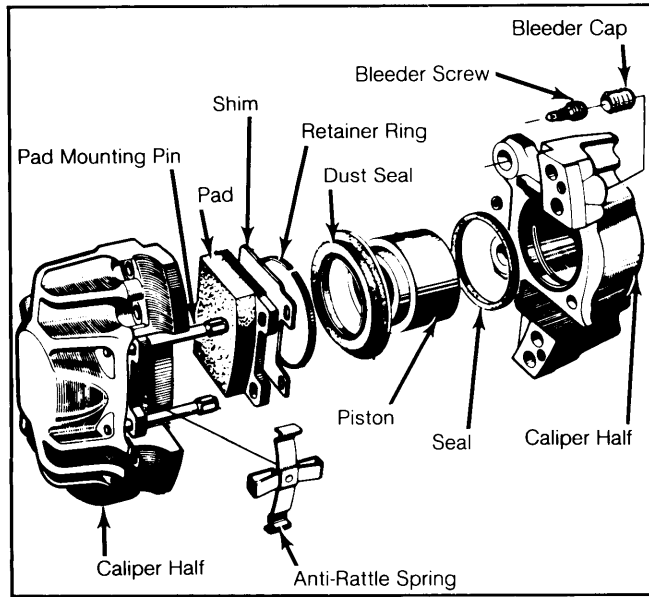

Do not separate caliper halves.

Cleaning & Inspection

Wash all parts in clean brake fluid. Inspect cylinder bores and pistons for corrosion, damage or wear. Replace defective parts. Replace all rubber parts during overhaul.

Fig. 4: Chrysler Corp. Pinion Gauge Tool Set (C-3715-L)

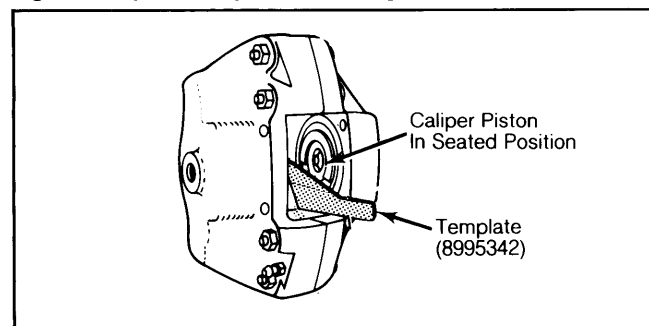

Template gauge must be held against lower surface of caliper.

DISC BRAKE ROTOR SPECIFICATIONS

Application	Disc Diameter In. (mm)	Lateral Runout In. (mm)	Parallelism In. (mm)	Original Thickness In. (mm)	Min. Refinish Thickness In. (mm)	Discard Thickness In. (mm)
900 & 900 Turbo Front	10.8 (276)	.004 (.10)	.0006 (.015)	.500 (12.7)	.461 (11.7)
Rear	10.5 (267)	.004 (.10)	.0006 (.015)	.413 (10.5)	.374 (9.5)

Reassembly

1) Coat all parts with clean brake fluid and install new piston seals in cylinder bores. Carefully install pistons into cylinder bores.

2) Check piston position with template (89 953 42). See Fig. 4. Install rubber boots and retaining clips. Install bleeder screw and disc pads.

MASTER CYLINDER

Disassembly

1) With master cylinder removed from vehicle, drain brake fluid from reservoir. Mount cylinder in a soft jawed-vise. Remove retaining pins and separate reservoir from master cylinder (pins may have to be driven out).

2) Remove rubber seals from reservoir mounting holes in cylinder. Push in on primary piston and pull secondary piston stop pin from forward reservoir mounting hole.

3) Remove circlip and take out primary piston assembly and spring. Remove cylinder from vise and carefully knock it against a block of wood to remove secondary piston assembly and spring.

4) Remove brake warning switch from master cylinder, then remove end plug and lift out warning valve assembly.

Cleaning & Inspection

Wash all parts in clean brake fluid and dry with a clean, lint-free cloth. Inspect all parts for corrosion, damage or wear. Replace defective parts. Replace rubber parts during overhaul.

Reassembly

Reverse disassembly procedure. Coat all parts with clean brake fluid and use care not to damage seals during installation of pistons.

Fig. 5: Exploded View of Master Cylinder

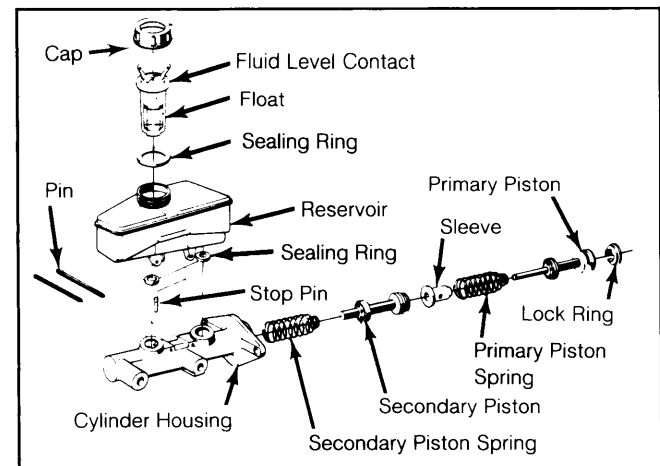

Illustration shows Girling master cylinder.