

MERCEDES-BENZ

240D, 300 Series, 380 Series

DESCRIPTION

Service brake system utilizes 4-wheel disc brakes. They are hydraulically-operated by a step-type or tandem master cylinder and power brake unit. Step-type master cylinder can be identified by a stop screw located on top center of master cylinder.

Tandem master cylinder stop screw is located at bottom center of master cylinder. Cylinders are manufactured by Teves or Bendix, and incorporate a 2- or 3-chamber reservoir. A fluid level sensor contact is built into each chamber.

A warning light is activated when fluid level is low. Parking brakes are cable-actuated, internal expanding shoe-type, housed in rear brake rotors.

ADJUSTMENT

PEDAL HEIGHT & FREE PLAY

1) Pedal height (measured from pedal pad to pedal stop) should be 5.9" (150 mm).

2) To adjust pedal height, loosen lock nuts and turn stop light switch until correct height is obtained.

3) Tighten lock nuts. Pedal free play should be .2-.6" (5-15 mm).

STOP LIGHT SWITCH

Stop light switch is located under dash, above brake pedal. To adjust, loosen lock nuts and adjust switch so that contact button extends .24-.32" (6-8 mm). Tighten lock nuts.

PARKING BRAKE

1) Remove 1 wheel lug bolt at each rear wheel. Raise and support vehicle. Rotate wheel until lug bolt hole is positioned over parking brake adjuster (approximately 45° in upward and forward direction from wheel center). See Fig. 1.

Fig. 1: Fitting Parking Brake Adjuster Tool Into Adjusting Mechanism

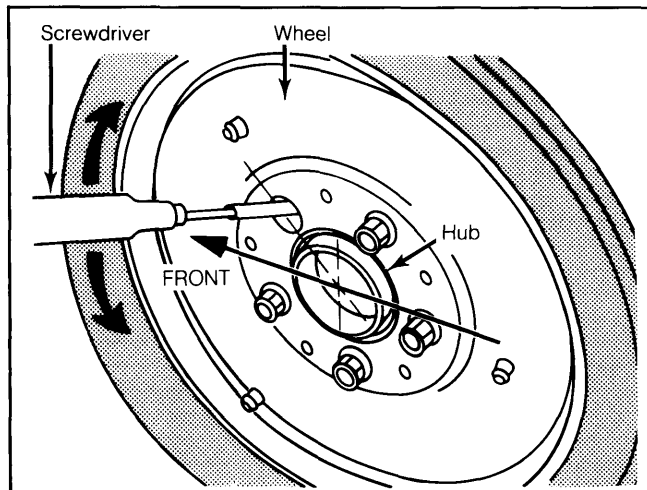

Screwdriver may be inserted through any rear lug bolt hole to adjust parking brake.

2) Using a screwdriver inserted through lug bolt hole, turn adjuster until wheel cannot be turned by hand. Back off adjuster until wheel can be turned by hand without drag.

BRAKE WARNING LIGHT

1) A dual warning light is mounted on dash. Light should glow when parking brake lever is pulled 1 notch and go off when lever is fully released (ignition on).

2) To check circuit warning sensor, release parking brake (ignition on) and ensure light is off. Open bleeder screw on 1 wheel and depress brake pedal; light should glow.

3) Close bleeder screw, replenish brake fluid and bleed hydraulic system.

REMOVAL & INSTALLATION

DISC PADS

Removal (300SD, 380SEC, & 380SEL)

1) Raise vehicle, support with safety stands and remove wheels. Remove upper hex-head caliper bolt.

2) Pull clip of brake pad wear sensor out of plug by opening cap on plug. Rotate caliper downward, and remove disc pads from carrier.

NOTE: All bolts are self-locking hex-head and should be used once only.

Fig. 2: Mercedes-Benz Single Piston Brake Caliper

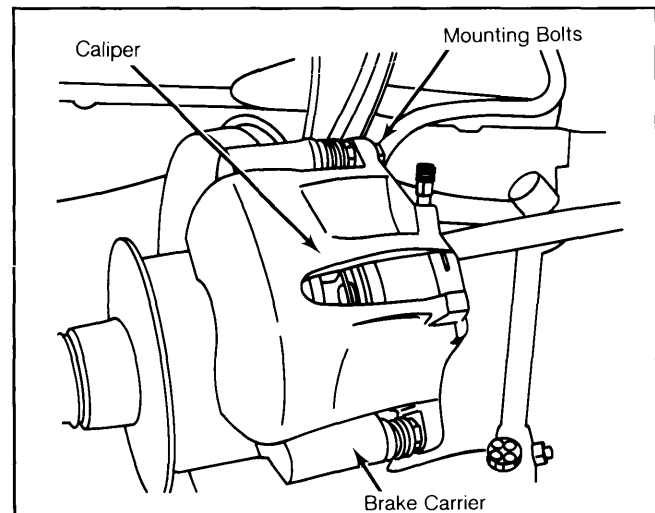

This front disc brake caliper is used on 300SD, 380SEC, & 380SEL.

Installation

1) Using a cylinder brush, clean disc pad guide surface in caliper. Siphon sufficient fluid from master cylinder reservoir to prevent overflowing, then press pistons to bottom of bores

2) Install disc pads and install wear sensor wires. Reverse removal procedure to complete installation.

Removal (All Other Models)

1) Raise vehicle, support with safety stands and remove wheels. If equipped, remove cover plate from caliper and disconnect wear indicator wires.

Brakes

MERCEDES-BENZ (Cont.)

2) Drive out retaining pins toward inside of vehicle (on Bendix brakes, retaining pins have locking keys). See Fig. 3. Remove cross spring.

3) Remove disc pads from caliper assembly.

NOTE: All bolts are self-locking hex-head and should be used once only.

Fig. 3: Removing Disc Pad Mounting Pins On Teves Model Brakes

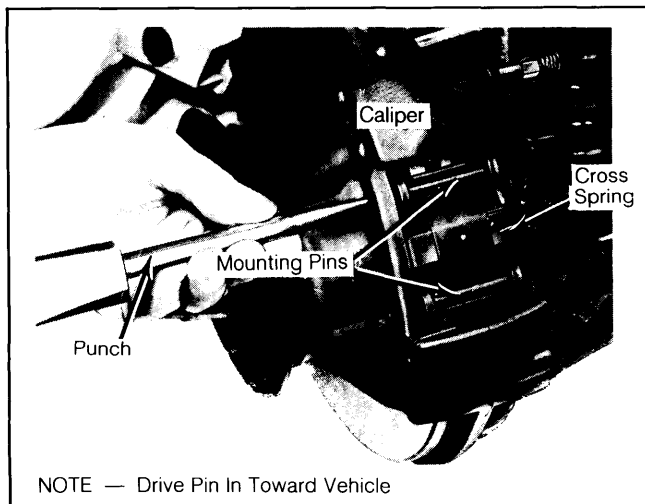

Drive mounting pin in toward vehicle.

Installation

1) Using a cylinder brush, clean disc pad guide surface in caliper. Siphon sufficient fluid from master cylinder reservoir to prevent overflowing, then press pistons to bottom of bores

2) Apply Molykote to back of disc brake pads. See Fig. 4. Install disc pads, cross spring and retaining pins. If equipped, install cover plate, retaining pin locking keys and wear sensor wires.

Fig. 4: Mercedes-Benz Disc Brake Pad

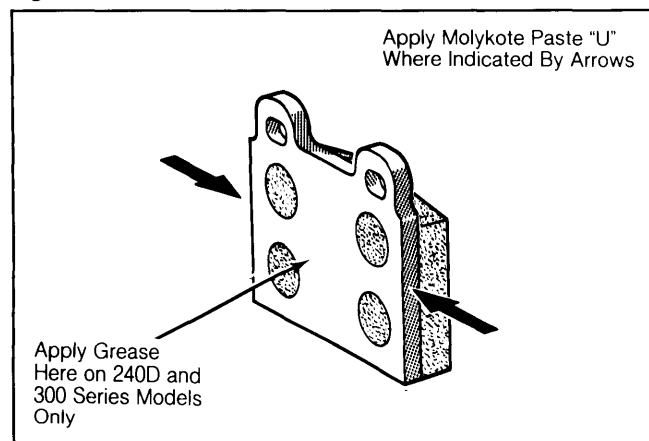

Illustration shows Molykote application points.

BRAKE CALIPER

Removal

1) Raise and support vehicle, and remove wheel. Disconnect brake lines at caliper assembly, and plug lines to prevent entry of foreign matter.

2) Remove caliper attaching bolts, and remove caliper assembly from vehicle.

Installation

Reverse removal procedure. Tighten all nuts and bolts and bleed hydraulic system.

BRAKE ROTOR

Removal (Front)

1) With caliper assembly removed, remove hub grease cap. Remove contact spring for radio shielding. Loosen clamping nut socket screw on wheel spindle.

2) Remove clamping nut and washer. Remove wheel hub and rotor assembly. Remove bolts securing hub to rotor and remove rotor.

Installation

To install, reverse removal procedure, tighten all bolts and fittings evenly and bleed hydraulic system (if necessary). Adjust wheel bearings.

Removal & Installation (Rear)

Remove gear wheel and caliper assembly, then pull rotor out from axle shaft flange. To install, reverse removal procedure, tighten all bolts and fittings evenly, and bleed hydraulic system if necessary.

Fig. 5: Assembled View of Rear Hub & Caliper

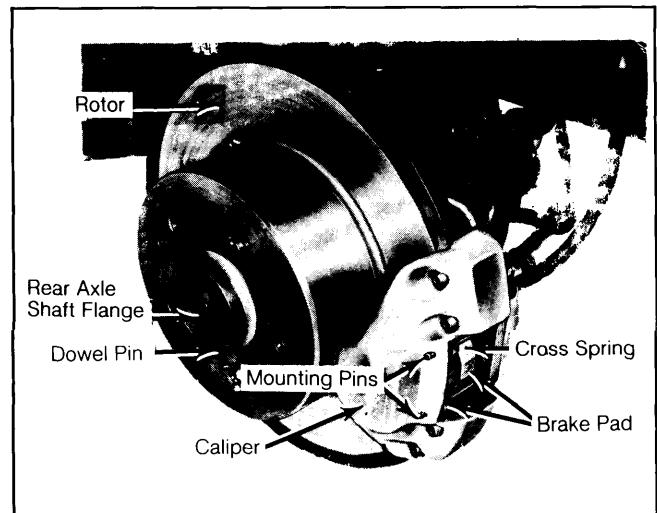

MASTER CYLINDER

Removal

1) Drain master cylinder brake fluid. Disconnect and plug brake lines, disconnect electrical wires.

2) Remove bolts securing master cylinder to power booster and remove master cylinder.

Installation

1) Reverse removal procedure and note the following: Always replace rubber "O" ring seal between master cylinder and power unit.

2) Bleed hydraulic system and check complete system for fluid leaks.

POWER BRAKE UNIT

Removal

1) Drain master cylinder and remove master cylinder from vehicle. Disconnect vacuum line at power brake unit and disconnect push rod at brake pedal.

2) Remove power brake unit attaching hardware and remove assembly from vehicle.

MERCEDES-BENZ (Cont.)

Installation

To install, reverse removal procedure, tighten all nuts and bolts, and bleed hydraulic system.

OVERHAUL

BRAKE CALIPER

Disassembly (300SD, 380SEC, & 380SEL)

1) With caliper removed from vehicle. Place a piece of wood in front of piston, apply compressed air to fluid inlet to remove piston.

2) Remove dust boot from piston and piston seal from caliper bore.

Cleaning & Inspection

1) Wash all parts in alcohol or brake fluid and air dry. Inspect cylinder bore and piston for scoring, scratches or rust.

2) Always replace dust boot and piston seal when caliper is disassembled. Small rust deposits may be removed with crocus cloth.

Reassembly

Coat piston and caliper bore with ATE brake cylinder paste (or equivalent), install piston seal into caliper bore. Install piston and dust boot.

Disassembly (All Other Models)

1) With caliper removed from vehicle and disc pads removed from caliper, remove dust boot.

2) Hold one piston in place using a clamp, then apply compressed air to fluid inlet to remove opposite piston.

3) Remove piston seal from groove of cylinder bore. Remove remaining piston and seal in same manner.

NOTE: DO NOT separate caliper halves.

CAUTION: DO NOT polish chrome-plated surfaces of pistons.

Cleaning & Inspection

1) Remove deposits on pistons with a soft brass wire brush. Check cylinder bore of caliper for wear or damage.

2) Small rust deposits may be removed with polishing cloth. Heavier deposits in front of piston seal groove may be removed with fine emery cloth.

Fig. 6: Disassembled View of Dual Piston Mercedes-Benz Brake Caliper

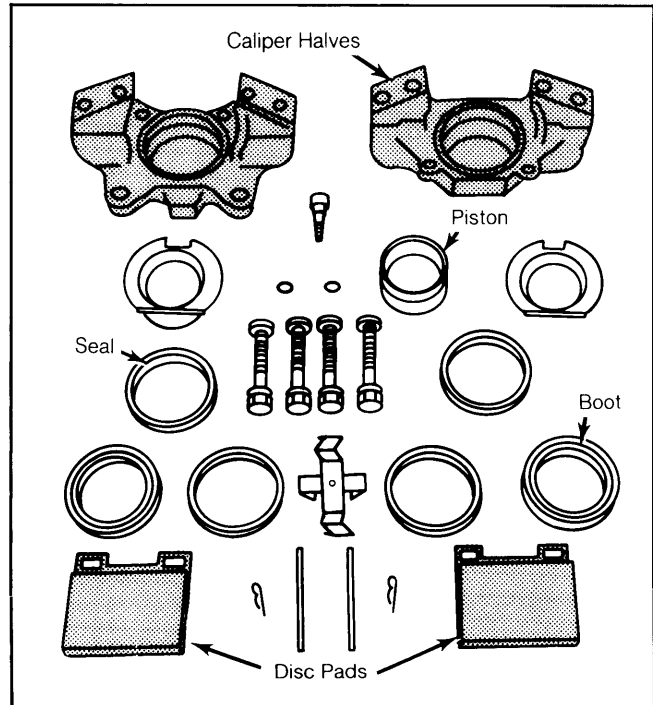

Do not separate caliper halves.

Fig. 7: Sectional View of Tandem Master Cylinder

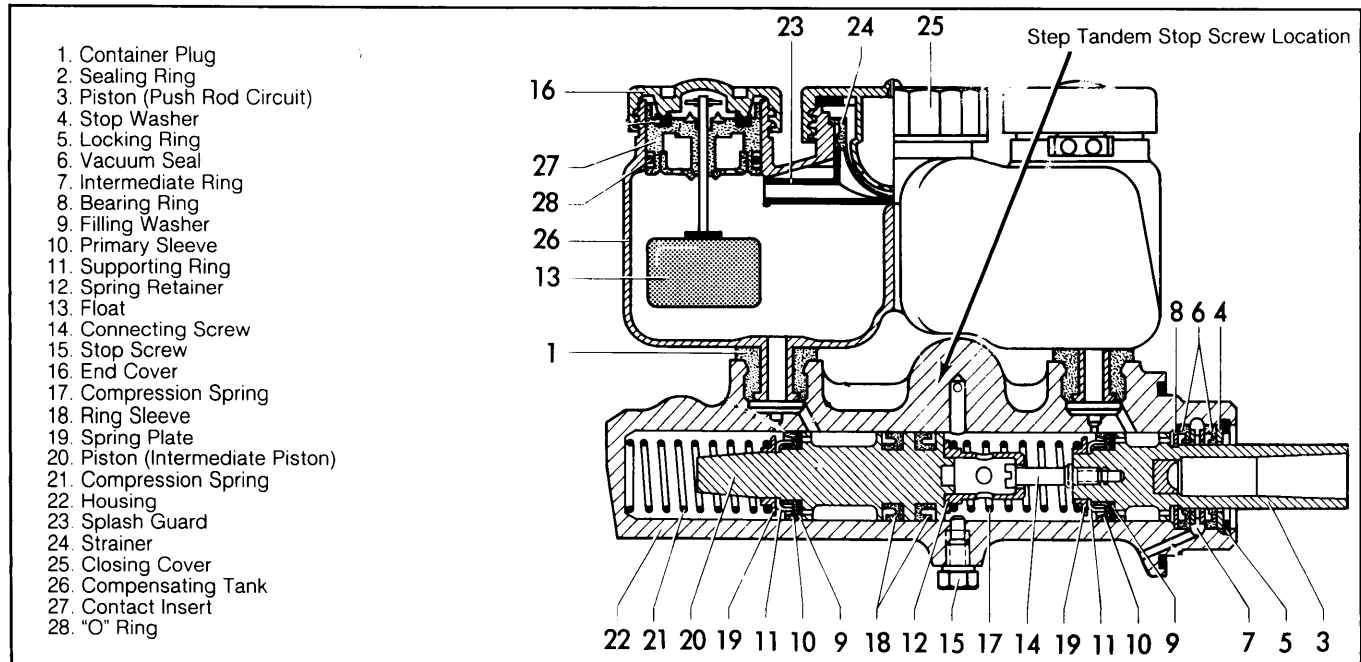

Brakes

MERCEDES-BENZ (Cont.)

Reassembly

1) Coat piston and caliper bore with ATE brake cylinder paste (or equivalent), install piston seal into caliper bore and install piston.

2) Install dust boot, then install heat shield into piston with recess in shield fitting into elevation of piston.

NOTE: Elevation on piston **MUST** face downward and project at least .004" (.1 mm) above shield.

MASTER CYLINDER

CAUTION: Bendix master cylinder, spray painted blue, cannot be repaired.

Disassembly (Tandem and Step Tandem)

1) Remove reservoir, push piston in with screwdriver, then remove stop screw and "O" ring.

2) Remove lock ring from housing, then remove piston, stop washer, 2 vacuum seals and intermediate ring.

3) Remove intermediate piston by tapping lightly on housing with a plastic mallet.

NOTE: Teves reservoir only, remove cap, end covers, strainer, splash guard, "O" rings and

contact inserts. Bendix model, remove strainer from cover. **DO NOT** remove contact inserts. All models, master cylinder diameter should be .937" (23.81 mm).

Inspection

1) Clean all parts with alcohol or brake fluid. Check bore in housing and piston for scoring and rust.

2) Small rust spots in housing may be removed with polishing cloth. Scored or badly rusted parts cannot be repaired, replace complete master cylinder.

Reassembly

Reverse disassembly procedure and bleed hydraulic system.

TIGHTENING SPECIFICATIONS

Application	Ft. Lbs. (N.m)
Caliper Mounting Bolts	
Front	1 83 (113)
Rear	65 (88)
Hub-to-Rotor Bolts	83 (113)

¹ — Tighten to 26 Ft. Lbs. (35 N.m) on 300SD, 380SEC, & 380SEL.

DISC BRAKE ROTOR SPECIFICATIONS

Application	Disc Diameter In. (mm)	Lateral Runout In. (mm)	Parallelism In. (mm)	Original Thickness In. (mm)	Min. Refinish Thickness In. (mm)	Discard Thickness In. (mm)
240D, & 300 Series						
Front005 (.12)	.0008 (.02)	.496 (12.6)417 (10.6)
Rear005 (.12)	.008 (.02)	.394 (10)327 (8.3)
380 Series						
Front005 (.12)	.0008 (.02)	.866 (22)787 (20)
Rear005 (.12)	.0008 (.02)	.394 (10)327 (8.3)