

Brakes

DATSUN/NISSAN 200SX, 280ZX, MAXIMA, SENTRA & STANZA

DESCRIPTION

Brake system is hydraulically operated using tandem master cylinder and vacuum power unit. Front brakes of Maxima, Sentra and Stanza are sliding caliper disc; rear are leading/trailing drum. Front brakes of 280ZX are sliding caliper disc; rear brakes are fixed caliper, sliding yoke disc.

Front and rear brakes of 200SX are fixed caliper, sliding yoke disc. Brake systems are equipped with a combination valve to prevent premature lockup of rear wheels. Service brake systems are self-adjusting. Parking brake is cable actuated on rear brake systems.

ADJUSTMENT

PEDAL HEIGHT & FREE PLAY

1) Adjust pedal height (measured from pedal pad to floor) to specification shown in table by moving stop light switch. Loosen operating rod lock nut and turn operating rod to attain proper height, tighten lock nut and adjust stop light switch.

2) Pedal free play on Sentra should be .43-.83" (11-21 mm). Pedal free play on all other models should be .04-.20" (1-5 mm). If specification is exceeded, on the Sentra adjust pedal stopper; on all other models adjust push rod length.

PEDAL HEIGHT SPECIFICATIONS

| Application | Pedal Height In. (mm) |
|-------------------|--------------------------|
| Maxima | 6.5-6.7 (164-170) |
| Sentra | 7.9-8.1 (201-207) |
| Stanza | |
| Man. Trans. | 5.8-6.1 (149-155) |
| Auto Trans. | 5.9-6.2 (151-157) |
| 200SX | 6.5-6.7 (165-171) |
| 280ZX | |
| Man. Trans. | 7.1-7.4 (181-187) |
| Auto. Trans. | 7.5-7.7 (190-196) |

STOP LIGHT SWITCH

Stop light switch is located under dash panel at brake pedal. Adjust travel during pedal height adjustment. After obtaining correct pedal height, position stop light switch until it just contacts brake pedal arm. Tighten lock nut.

PARKING BRAKE

Maxima, Sentra, & 200SX

Adjust parking brake by rotating turnbuckle. Rear wheels should lock when brake lever is pulled 7-8 notches with 44 lbs. (20 kg.) force. After releasing lever, ensure rear wheels rotate freely, rear cables are not slack and that rear brake toggle levers are in original positions.

Stanza

Adjust front cable adjusting nut so when parking brake lever is pulled with 44 lbs. (20 Kg) force, lever stroke is 7-8 notches and rear wheels are locked. After releasing lever, ensure rear wheels rotate freely, rear cables are not slack and that rear brake toggle levers are in original positions.

280ZX

Adjust front cable adjusting nut so when parking brake lever is pulled with 60 lbs. (27 kg) force, lever stroke is 4-6 notches and rear wheels are locked. After releasing lever, ensure rear wheels rotate freely, rear cables are not slack and that rear brake toggle levers are in original positions.

Fig. 1: Location for Adjusting 280ZX Parking Brake

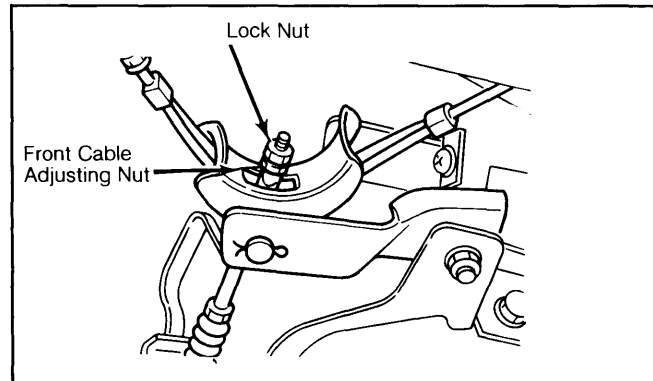

BRAKE WARNING LIGHT

Light indicates parking brake is engaged and also warns of low brake fluid level. To adjust light operation with parking brake applied, bend switch plate down until light comes on when brake lever is pulled up 1 notch and goes out when lever is released (ignition on).

To check warning light operation, release parking brake lever and raise master cylinder reservoir cap (ignition on). Warning light should glow. If not, check switch and wire connector.

REMOVAL & INSTALLATION

FRONT DISC BRAKE PADS

Removal (200SX)

Raise and support vehicle; remove tire and wheel. Remove retaining pin clips, retaining pins and pad springs. Remove pads from caliper assembly, using pliers if necessary.

CAUTION: DO NOT force piston groove inside piston seal. Piston seal could be damaged and caliper will have to be disassembled.

Installation

1) Clean and apply P.B.C. grease to cylinder body yoke guide groove, yoke sliding contact points and piston end surface. Loosen bleeder screw and push outer piston into cylinder until piston end surface coincides with boot retaining ring end surface. Tighten bleeder screw and install inner brake pad.

2) Push inner piston into cylinder by pulling on yoke, then install outer pad. Install pad springs, retaining pins and clips. Depress brake pedal several times to seat pads and bleed hydraulic system.

Removal (Except 200SX)

Raise and support vehicle. Remove tire and wheel. Remove lower pin bolt. Rotate caliper body upward. Remove pad retainers, shims and brake pads.

DATSUN/NISSAN 200SX, 280ZX, MAXIMA, SENTRA & STANZA (Cont.)

NOTE: Do not pull caliper body away from rotor; use upper pin bolt as center of rotation.

Installation

1) Clean piston and area around pin bolts with brake fluid. Install inner pad and seat piston by placing lever through opening in caliper body and pushing piston into bore. Apply brake grease to pad retainer points on caliper assembly and install outer pad and both shims.

Fig. 2: Front Disc Brake Pad Retainer Location

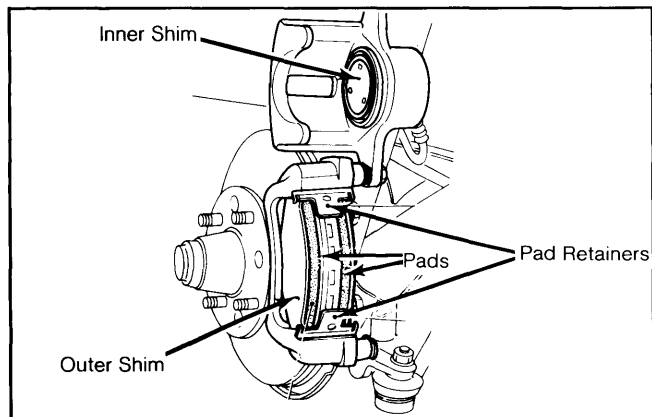

2) Install pad retainers. Rotate caliper body down into original position and install lower pin bolt. Tighten pin bolt and depress brake pedal several times to seat pads.

FRONT DISC BRAKE CALIPER

Removal

Raise and support vehicle. Remove wheel and tire. Disconnect and plug brake line from caliper. Remove caliper mounting bolts and remove caliper assembly.

Installation

To install, reverse removal procedure, tighten caliper bolts securely and bleed hydraulic system.

FRONT DISC BRAKE ROTOR

Removal

1) Remove caliper assembly as previously described and hang from frame with wire; DO NOT disconnect hydraulic line. Remove hub dust cap, "O" ring, cotter pin, adjusting cap and lock nut.

2) Remove hub and rotor assembly from spindle without dropping outer bearing and washer. Remove outer bearing, washer and hub-to-rotor bolts. Separate rotor from hub.

NOTE: Avoid damage to hub dust cap "O" ring during removal of dust cap.

Installation

Reverse removal procedure and adjust wheel bearings. See *Wheel Bearing Adjustment in SUSPENSION Section*.

REAR DISC BRAKE PADS

Removal

Raise and support vehicle. Remove tire and wheel. Remove pin clip, then remove pad pins while holding anti-squeal springs with finger. Remove disc pads and shims (if equipped).

Installation

1) Apply brake grease to caliper body-to-pad clearance, yoke-to-pad clearance, pin-to-pad clearance, pin-to-bracket clearance and both sides of shims (Maxima and 200SX). Apply silicon grease to friction surface of installing pads by pushing and turning outer piston clockwise until it retracts into caliper bore.

NOTE: Avoid damaging dust seal while turning outer piston.

2) Place lever between yoke and bore and move yoke until clearances to install pads are equal. Align outer piston so cut out portion is level. Install inner pad with protrusion of pad seated in piston cut out. Install shims on Maxima and 200SX.

3) Install outer pad, anti-squeal springs, pad pins and pin clip. Depress brake pedal several times to adjust clearance. Pad-to-rotor clearance is correct when pedal stroke is constant. Add brake fluid and bleed hydraulic system.

REAR DISC BRAKE CALIPER

Removal

Disconnect hydraulic line from caliper and plug openings. Disconnect parking brake cable. Remove mounting bolts and remove caliper.

Installation

Reverse removal procedure and bleed hydraulic system if necessary. Depress brake pedal several times; when pedal stroke is constant, brake pad-to-rotor clearance is properly adjusted. Turn rotor to make sure no excessive drag is present.

REAR DISC BRAKE ROTOR

Removal

With caliper removed, pull rotor from axle stub.

Installation

Install rotor and caliper assembly. After installation, depress pedal until pedal stroke is constant to adjust pad-to-rotor clearance.

MASTER CYLINDER

Removal

Remove heat shield plate (if equipped). Disconnect brake fluid level gauge wiring and hydraulic lines from master cylinder. Remove master cylinder-to-power unit mounting nuts and remove master cylinder from power brake unit.

Installation

Reverse removal procedure, check pedal height and bleed hydraulic system.

POWER BRAKE UNIT

NOTE: Before removal, test check valve. Using brake booster tester, apply 7.9 in. Hg to brake unit side of check valve on 200SX. Apply 19.7 in. Hg to check valve on Maxima. If pressure drops more than .4 in. Hg in 15 seconds, replace check valve. Also, if valve does not open when pressure is applied to brake unit side of check valve, replace check valve. If valve is not defective, check brake system and vacuum lines for leaks. Repair as needed.

Brakes

DATSUN/NISSAN 200SX, 280ZX, MAXIMA, SENTRA & STANZA (Cont.)

Removal

1) Disconnect power unit push rod from brake pedal by removing clevis pin. Disconnect hydraulic lines from master cylinder, vacuum line from power unit, remove master cylinder mounting nuts, and remove master cylinder.

2) Remove nuts attaching power unit to firewall, and remove power unit from engine compartment.

Installation

1) Reverse removal procedure and check push rod length, operating rod length and pedal height. Push rod on Maxima and 200SX Can NOT be adjusted. If not to specification, replace power unit. Adjust push rod length on 280ZX by turning tip of push rod.

Fig. 3: Measuring Push Rod and Operating Rod Lengths

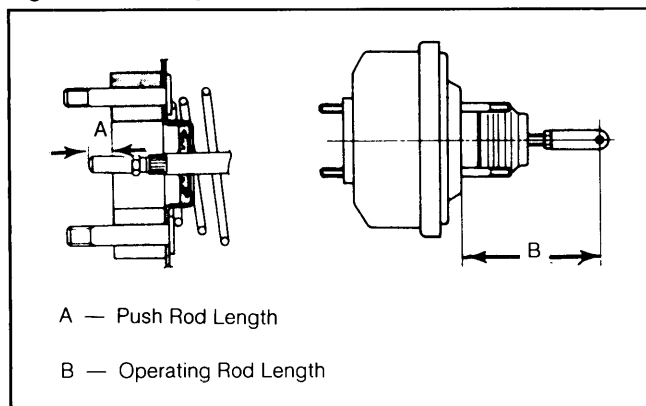

Push rod on Maxima & 200SX cannot be adjusted.

2) Adjust operating rod length by loosening lock nut and turning operating rod to attain proper length. Tighten lock nut and clevis. Bleed hydraulic system.

PUSH ROD & OPERATING ROD LENGTHS

| Application | Push Rod In. (mm) | Operating Rod In. (mm) |
|--------------|----------------------|---------------------------|
| Maxima | 5.7 (145) | .38-.39 (9.8-10.0) |
| Sentra | 5.9 (150) | .40-.41 (10.2-10.5) |
| Stanza | 5.1 (130) | .38-.39 (9.75-10.0) |
| 200SX | 5.1 (130) | .38-.39 (9.75-10.0) |
| 280ZX | 5.6 (143) | .37-.41 (9.5-10.5) |

Check Valve Replacement

Check valve is located in vacuum line between intake manifold and power unit on firewall. To remove, disconnect retaining clip from firewall, remove hose clamps, separate hoses from valve, and remove check valve. To install, reverse removal procedure.

OVERHAUL

FRONT DISC BRAKE CALIPER

Disassembly (200SX)

1) With caliper and pads removed, drain any remaining fluid from cylinder. Remove gripper pin attach-

ing bolts. Separate yoke and cylinder body. Remove yoke holder from piston.

2) Remove retaining rings and dust seals from pistons. Push both pistons out in one direction. Remove piston seals. Remove gripper, if necessary.

Cleaning & Inspection

Clean all parts with brake fluid and check all components for wear or damage. If minor corrosion cannot be removed from cylinder bore with fine emery cloth, cylinder must be replaced. Replace all seals during overhaul.

NOTE: Piston surfaces are plated and must be replaced if corroded or worn. DO NOT polish with emery cloth.

Reassembly

1) Install piston seals without damaging seals. Coat cylinder bore and pistons with brake fluid. Push outer piston into cylinder until piston end surface coincides with boot retaining ring end surface.

2) Do not force piston groove inside piston seal. Push inner piston into cylinder bore by holding cylinder body and align piston yoke groove with cylinder yoke groove.

3) Apply brake grease to sealing surface of dust seal and install dust seal; clamping securely with retaining ring. Install yoke holder to inner piston. Install gripper to yoke. Apply 1% soap solution to inner gripper wall and drive gripper pin into position.

4) Install yoke to yoke-holder by supporting outer piston end and pressing yoke into yoke-holder with 44-66 lb. (20-30 kg) force. No clearance should be present between piston and yoke.

Fig. 4: Exploded View of 200SX Front Disc Brake Caliper

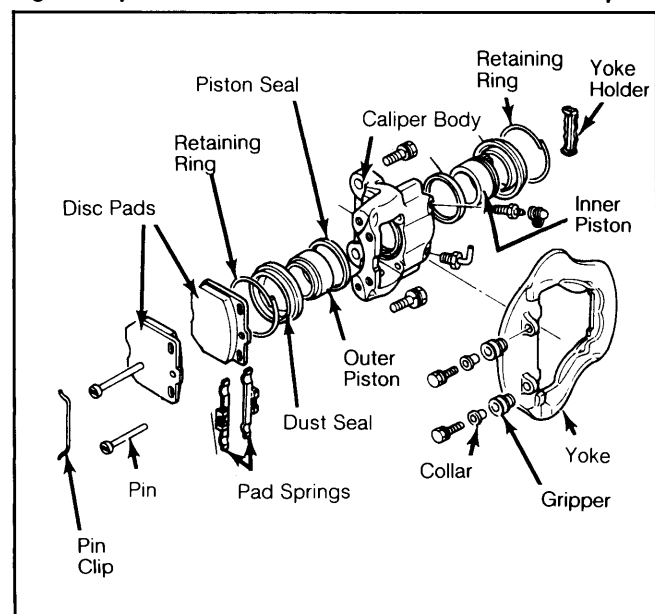

No clearance should be present between piston and yoke.

Disassembly (All Others)

1) Drain brake fluid from caliper body and clean exterior of caliper assembly. Remove pin bolts,

DATSUN/NISSAN 200SX, 280ZX, MAXIMA, SENTRA & STANZA (Cont.)

separate caliper body from pad carrier and remove pad retainers and pads.

2) Force piston and dust seal out of bore by applying compressed air to brake inlet. Remove piston seal without damaging seal and bore. Remove sub pin, main pin, sub pin bushing and seals.

Cleaning & Inspection

1) Clean all parts in brake fluid only. Check caliper bore for wear, rust, corrosion or other damage; minor deposits or scratches can be removed with fine emery cloth. Check pad carrier for wear, cracks or other damage. Replace if defective.

2) Check piston for rust, wear or damage. Replace if defective. Check main pin and sub pin for wear, cracks or other damage. Replace if defective. Replace piston seal and dust seals during overhaul.

Reassembly

1) Apply brake fluid to sliding portions of piston and caliper bore. Apply rubber grease to inside of dust seals. Install piston seal in bore. Install dust seal on piston and slide piston into caliper bore. Secure dust seal in piston groove and caliper groove.

2) Apply multi-purpose grease to sub pin rubber bushing, main pin and sub pin. Install seals, sub pin rubber bushing, sub pin and main pin. Apply brake grease to disc pad-to-carrier contact portions and mount pad carrier to caliper body.

3) Install upper pin bolt, install disc pads, shims and rotate caliper down into position and install lower pin bolt. When caliper assembly is mounted on vehicle, turn rotor to ensure there is not excessive drag.

Fig. 5: Exploded View of 280ZX Front Disc Brake Caliper

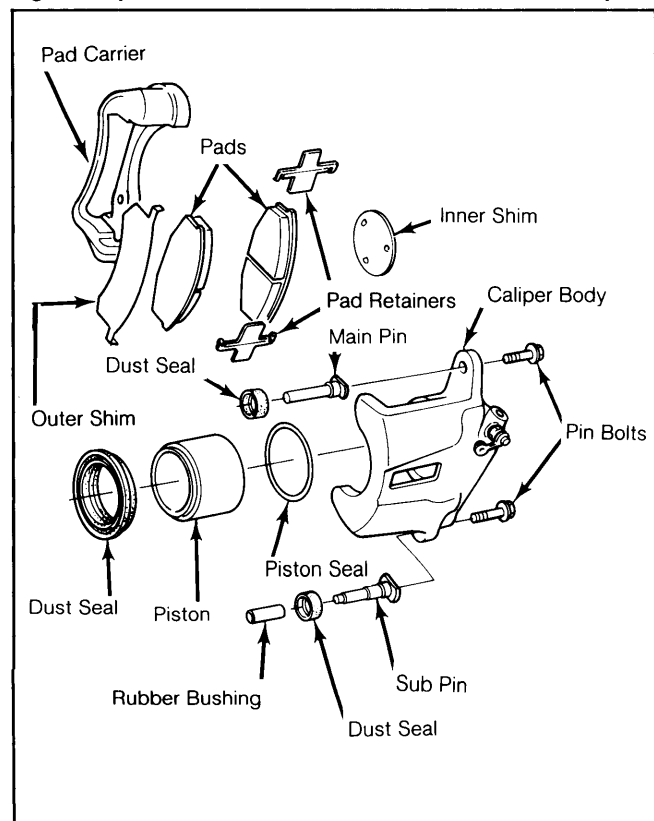

Single piston design, Maxima, Sentra, & Stanza are similar.

REAR DISC BRAKE CALIPER

Disassembly

1) Drain brake fluid from caliper body and clean exterior of caliper. Remove pads. Place caliper assembly on a work bench with yoke down. Push in caliper body and separate caliper and yoke.

2) Remove retaining rings and dust seals from piston ends. Push outer piston to remove piston assembly from caliper bore. Remove piston seals without damaging caliper bore.

3) Disengage piston assembly by turning inner and outer pistons counterclockwise. Disassemble outer piston by removing outer piston snap ring. Remove spacers, wave washer, bearing, adjusting nut and oil seal.

4) To disassemble inner piston, remove inner piston snap ring. Remove spring cover, spring and spring seat. Remove push rod retaining ring, key plate, push rod, "O" ring and strut. Place parking brake lever in vise and remove nut, washer, return spring, lever, dust seal and cam.

Cleaning & Inspection

Clean all parts in brake fluid only. Check caliper bore for wear, rust, corrosion or other damage; minor deposits or scratches can be removed with fine emery cloth. Check yoke for wear, cracks or other damage; replace if defective. Check pistons for rust, wear or damage; replace if defective. Replace piston seals, dust seals, oil seal and push rod "O" ring during overhaul.

NOTE: DO NOT use abrasives on piston plated surfaces.

Reassembly

1) Apply grease to push rod groove, "O" ring, strut ends, oil seal, piston seals and inside dust seals. Install new oil seal on adjusting nut. See Fig. 7. Slide adjusting nut and seal into outer piston, then install bearing, spacer, wave washer, second spacer and secure components in position with outer piston snap ring.

2) Place cam inside inner piston and securely fit strut in cam hole. Install "O" ring on push rod without twisting "O" ring. Align square hole in key plate with push rod and slide assembly into inner piston bore; rounded portion of plate must seat in piston.

3) Install push rod retaining ring. Position spring seat, spring and spring cover in position. Hold spring and spring cover in position with drift and install inner piston snap ring.

NOTE: Do not use excessive force on spring cover; cover will require replacement if deformed.

4) Install toggle lever dust seal on cam (cam must face direction of parking brake operation) and align square hole in toggle lever on cam. Install return spring, lock washer and tighten nut. Reassemble piston assembly by turning clockwise.

5) Coat sliding portions of piston assembly and caliper bore with brake fluid. Slide piston assembly into bore (outside piston first) from rear of caliper assembly. Install new dust seals and secure in position with retainer rings.

6) Install yoke springs to yoke. Coat yoke and caliper body frictional surfaces and caliper body pad pin holes with silicone grease. Align cut out portion of inner

Brakes

DATSUN/NISSAN 200SX, 280ZX, MAXIMA, SENTRA & STANZA (Cont.)

Fig. 6: Exploded View of Rear Disc Brake Caliper

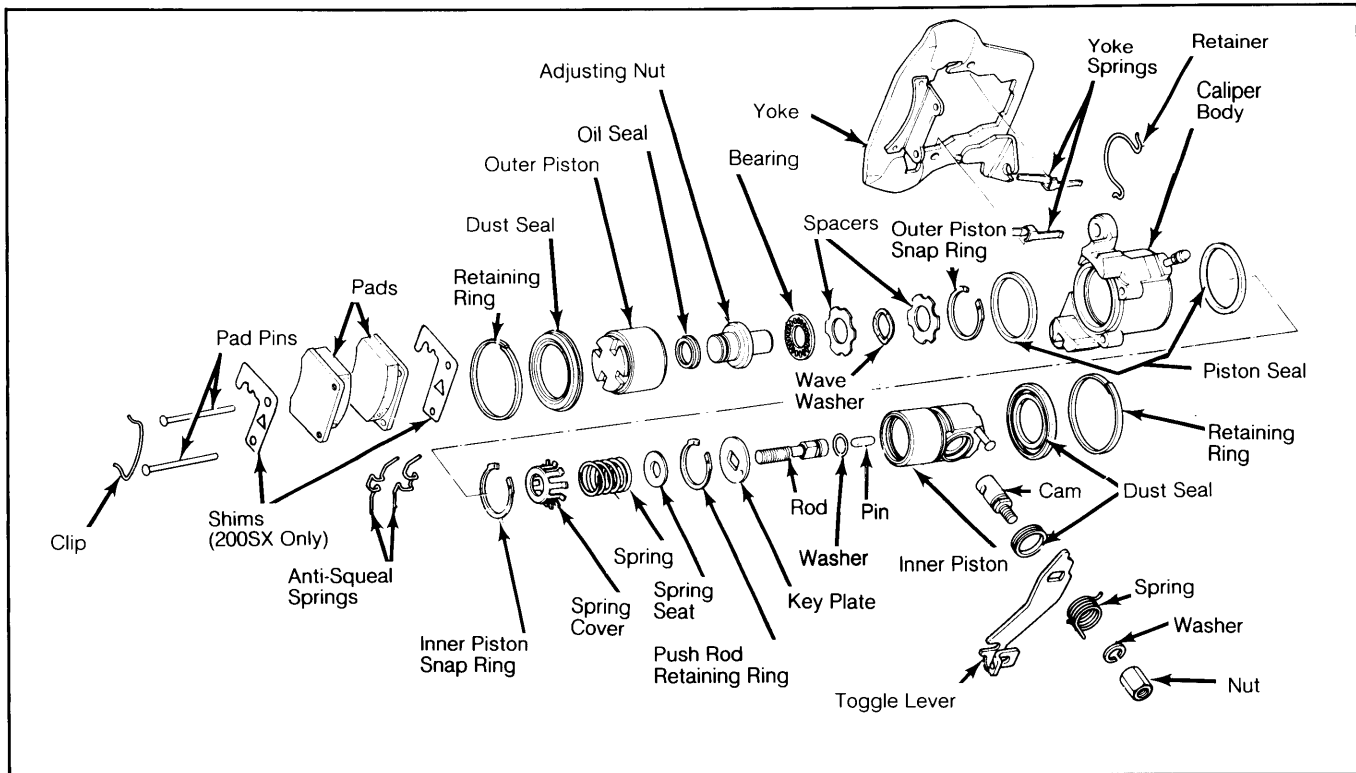

piston with yoke and reassemble yoke to caliper. Securely position retainer in piston groove.

7) Apply brake grease to caliper body-to-pad clearance, yoke-to-pad clearance, pad pin-to-pad clearance and pad pin-to-bracket clearance. Install pads, springs, pins and clip.

Fig. 7: Installation of Oil Seal on Rear Caliper Adjusting Nut

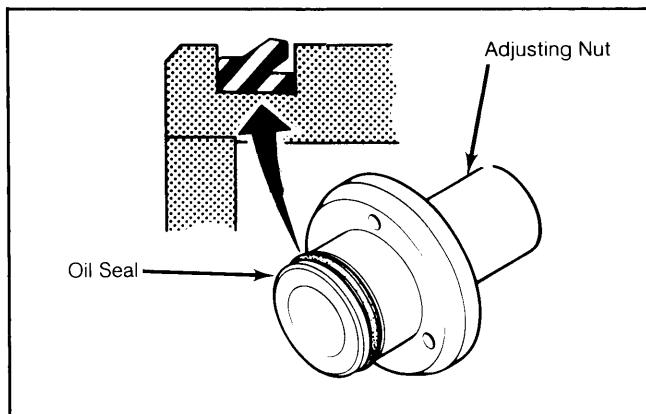

REAR BRAKE SHOES

Removal (All Models)

1) Raise and support vehicle. Remove tire and wheel. Apply parking brake and remove stopper pin. Remove stopper from lever. Release parking brake and remove brake drum.

2) Remove parking brake cable from backing plate. Remove retainers, anti-rattle springs, pins and

spring seats. Remove return springs and brake shoes. Remove dust cover and toggle lever with adjuster assembly.

Installation

Apply brake grease to all contact points and mating surfaces; reverse removal procedure to install brake shoes and note the following: Make sure adjuster operates properly, readjust shoe-to-drum clearance and bleed hydraulic system, if necessary.

REAR WHEEL CYLINDER

Disassembly

With rear wheel cylinder removed, remove dust covers and remove components.

Cleaning & Inspection

Clean all parts in brake fluid and check cylinder bore and pistons for excessive wear or damage. If piston-to-cylinder clearance is greater than .006" (.15 mm), replace necessary parts. Replace any torn or damaged rubber parts.

NOTE: Wheel cylinders are produced by two manufacturers and parts are not interchangeable. Ensure repair kit matches wheel cylinder.

Reassembly

Apply brake fluid to cylinder bore, pistons and piston cups. Reverse disassembly procedure and install parts.

DATSUN/NISSAN 200SX, 280ZX, MAXIMA, SENTRA & STANZA (Cont.)

Fig. 8: Exploded View of Rear Brake Assembly

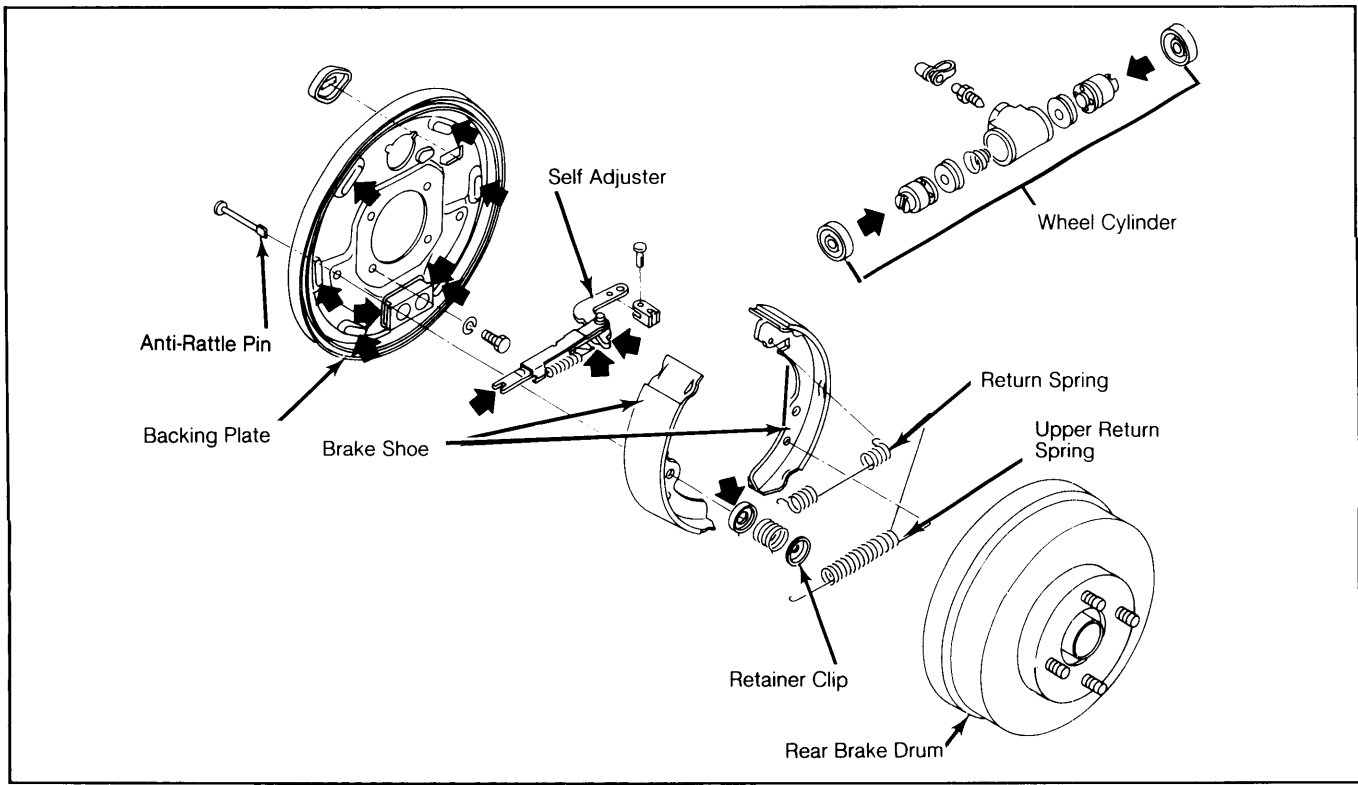

Component location may vary between models.

MASTER CYLINDER

Disassembly

Remove reservoir caps and filters. Drain brake fluid from reservoir. Remove snap ring and stopper bolt. Withdraw stopper, primary piston assembly, secondary piston assembly and springs. Remove check valve plugs and withdraw check valve assemblies.

NOTE: Do not remove reservoir tanks. If tanks are removed for any reason, discard and install new tanks. Also, do not remove or disassemble brake fluid level gauge.

Cleaning & Inspection

Clean all parts in brake fluid and check components for excessive wear or damage. If piston-to-cylinder clearance exceeds .006" (.15 mm) replace defective part. Caps, gaskets, packing and valves must be replaced during overhaul.

NOTE: Master cylinders are produced by two companies and parts are not interchangeable. Ensure repair kit matches master cylinder. Only "Tokico" master cylinder is used on 200SX.

Reassembly

Reverse disassembly procedure and note the following: Apply rubber grease to all rubber parts and brake fluid to remaining parts when assembling to prevent damage.

Fig. 9: Exploded View of Tokico Master Cylinder

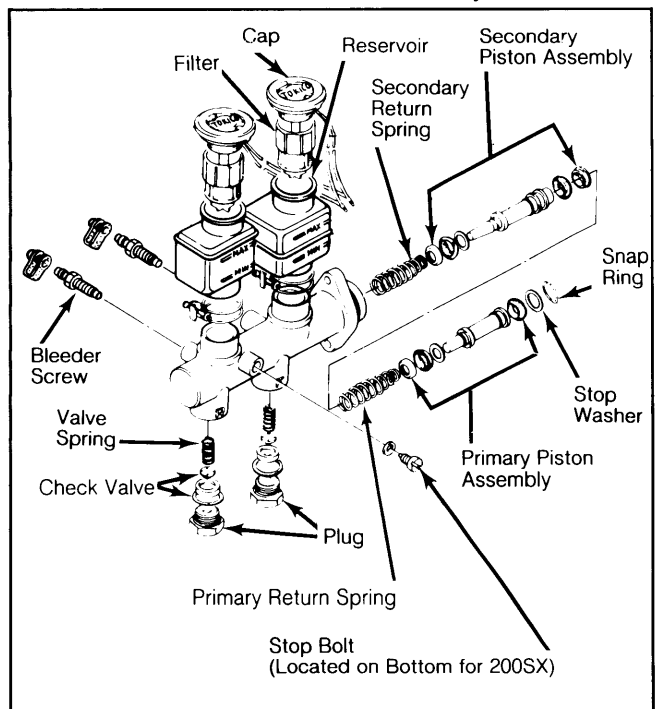

Nabco master cylinder is similar, but has different piston configuration for 280ZX.

Brakes

DATSUN/NISSAN 200SX, 280ZX, MAXIMA, SENTRA & STANZA (Cont.)

TIGHTENING SPECIFICATIONS

| Application | Ft. Lbs. (N.m) |
|---------------------------------|----------------|
| Hub-to-Rotor Bolts | |
| Maxima (Front) | 36-51 (49-69) |
| Sentra (Front) | 18-25 (25-33) |
| Stanza (Front) | 28-38 (38-52) |
| 200SX (Front) | 28-38 (38-52) |
| 280ZX (Front) | 40-54 (54-73) |
| Front Disc Brake Caliper | |
| Maxima | |
| Main & Sub Pins | 14-17 (19-24) |
| Sentra | |
| Caliper-to-Carrier Bolts | 16-23 (22-31) |
| Caliper-to-Mounting Bolts | 40-47 (54-64) |
| Stanza | |
| Caliper-to-Carrier Bolts | 12-15 (16-21) |
| Caliper-to-Mounting Bolts | 53-72 (72-97) |
| 200SX | |
| Yoke-to-Caliper Bolts | 12-15 (16-20) |
| Caliper Mounting Bolts | 53-72 (72-98) |
| 280ZX | |
| Caliper-to-Carrier Bolts | 16-23 (22-31) |
| Carrier-to-Mounting Bolts | 53-72 (72-98) |
| Rear Disc Brake Caliber | |
| Toggle Lever Nut | 18-22 (25-30) |
| Caliper Mounting Bolts | 28-38 (38-52) |

POWER BRAKE UNIT

NOTE: Manufacturer does not recommend disassembly of this unit. If a problem is determined to be in power brake unit, complete assembly must be replaced. Do not disassemble power brake unit.

DISC BRAKE ROTOR SPECIFICATIONS

| Application | Disc Diameter In. (mm) | Lateral Runout In. (mm) | Parallelism In. (mm) | Original Thickness In. (mm) | Min. Refinish Thickness In. (mm) | Discard Thickness In. (mm) |
|-------------|---------------------------|-----------------------------|-------------------------|--------------------------------|-------------------------------------|-------------------------------|
| Maxima | 9.84 (250) | .0059 (.15) | .0012 (.03) | .31 (8) | | .630 (16) |
| Sentra | 9.45 (240) | .0047 (.12) | .0012 (.03) | | | .433 (11) |
| Stanza | 9.13 (232) | .0059 | .0012 (.03) | | | .630 (16) |
| 200SX | | | | | | |
| Front | | .0047 ¹ (.12) | .0028 (.07) | .492 (12.5) | | .413 (10.5) |
| Rear | | .0059 ¹ (.15) | .0028 (.07) | .378 (9.6) | | .339 (8.6) |
| 280ZX | | | | | | |
| Front | | .0039 ¹ (.10) | .0012 (.03) | .787 (20) | | .709 (18) |
| Rear | | .0059 ¹ (.15) | .0012 (.03) | .378 (9.6) | | .339 (8.6) |

¹ - Maximum allowable at center of pad contact area.

DRUM BRAKE SPECIFICATIONS

| Application | Drum Diam. In. (mm) | Drum Width In. (mm) | Max. Drum Refinish Diam. In. (mm) | Brake Cyl. Diam. In. (mm) | Master Cyl. Diam. In. (mm) |
|-------------|------------------------|------------------------|--------------------------------------|------------------------------|-------------------------------|
| Maxima | 9.0 (228.6) | 1.57 (40) | 9.06 (230) | 7/8 (22.23) | 7/8 (22.23) |
| Sentra | 7.09 (180) | | 7.13 (181) | 11/16 (17.46) | 3/4 ¹ (19.05) |
| Stanza | 8.0 (203) | | 8.05 (204.5) | 11/16 (17.46) | 13/16 (20.64) |

¹ - Small master cylinder is shown, diameter of large master cylinder is 15/16 (23.81).