

CHRYSLER CORP. IMPORTS

Arrow Pickup, Challenger, Champ, Colt, Ram-50 Pickup, Sapporo

DESCRIPTION

Brake system is hydraulically-operated using a master cylinder with a single reservoir and 2 outlets, a vacuum power brake unit, and a proportioning valve to control braking action.

Champ and Colt models are equipped with pin caliper type front disc brakes. Arrow Pickup, Challenger, Ram-50 Pickup and Sapporo are equipped with sliding caliper type front disc brakes.

Rear brakes on all models are drum type, although rear disc brakes are available as an option on Challenger and Sapporo models. All drum brakes are self-adjusting. Parking brake cable actuates the rear drum brakes.

ADJUSTMENT

PEDAL HEIGHT & FREE PLAY

Back off stop light switch. To adjust pedal height (distance from top of pedal to floor board) loosen lock nut, and rotate master cylinder push rod (yoke, if equipped). DO NOT depress push rod. Tighten lock nut, and ensure that brake pedal free play is .4-.6" (10-15 mm) on all models.

PEDAL HEIGHT SPECIFICATIONS

Application	Pedal Height In. (mm)
Arrow Pickup & Ram-50 Pickup	6.5 (166)
Challenger & Sapporo	7.1 (180)
Champ & Colt	7.1-7.3 (180-185)

STOP LIGHT SWITCH

On Pickup models, adjust stop light switch until it just contacts brake pedal lever. On all other models, loosen lock nut and adjust switch-to-pedal arm clearance to .02-.04" (0.5-1.0 mm). Tighten lock nut. DO NOT depress master cylinder push rod during stop light switch adjustment.

PARKING BRAKE

Arrow Pickup & Ram-50 Pickup

1) Service brake adjustment must be accurate before making parking brake adjustment. Fully release parking brake and allow slack in rear cable to prevent brake shoe drag.

2) Set balancer-to-crossmember clearance to 8" (203 mm) by adjusting turnbuckle. Balancer must be parallel with center line of vehicle. Brake lever stroke should be 16-17 notches at 66 lbs. force.

Challenger & Sapporo

When parking brake lever is pulled with a force of 45 lbs., the lever stroke should be 4-6 notches. If it is not, remove the accessory box. Turn the adjusting nut until the specified number of notches is obtained with a pull of 45 lbs. force.

Champ & Colt

Remove parking brake lever cover, and release brake lever. Adjust both cables to equal lengths,

allowing enough slack in cables to prevent brake shoe drag. Properly adjusted parking brake lever stroke should be 6-7 notches at 44 lbs. force.

NOTE: On all models, if parking brake lever stroke is longer than specified after adjustment, automatic adjuster is malfunctioning.

TESTING

PROPORTIONING VALVES

Different types of proportioning valves are used between models. However, pressure testing is similar on all models. The following are special descriptions that apply by model:

- Arrow Pickup & Ram-50 Pickup — Valve accomplishes two functions: (1) Improves braking efficiency by distributing braking force to front and rear wheels. (2) Increases braking force to rear wheels when large braking force is required or front brakes fail.
- Challenger & Sapporo — Valve accomplishes three functions: (1) Pressure control of rear service brakes. (2) Deactivating rear brake pressure control when front service brakes fail. (3) Trouble warning.
- Champ & Colt — Valve body contains two separate proportioning valves and each valve must be checked separately. Valve body is identified with "A150" stamped on plug.

Pressure Test

Performed using 2 pressure gauges that measure at least 1500 psi. Hook one gauge to master cylinder rear side and the other to rear wheel cylinder. Pressure readings should be as shown in chart. Replace defective part as required. DO NOT disassemble proportioning valve.

NOTE: The proportioning valve on Champ and Colt models contains two valves. Each must be tested separately.

BRAKE HYDRAULIC PRESSURE CHART (psi)

Application	Wheel Cyl. Pressure	Master Cyl. Pressure
Arrow Pickup & Ram-50 Pickup		
B Valve	437-494	711
P Valve	668-754	966
Challenger & Sapporo		
With Rear Disc	674	853
With Rear Drum	532	711
Champ & Colt	519-590	953

Warning Light Test

To test warning light (if equipped), loosen bleeder screw of 1 wheel cylinder, and depress brake pedal. Warning light should come on. If not, check switch and wire connector.

Proportioning Valve Reset (Challenger & Sapporo Only)

After repairs on brake system, bleed brake lines. With all lines bled and bleeder valves secured, depress brake pedal hard. This will center valve and warning light should go out.

Brakes

CHRYSLER CORP. IMPORTS (Cont.)

Fig. 1: Sectional View of Proportioning Valve

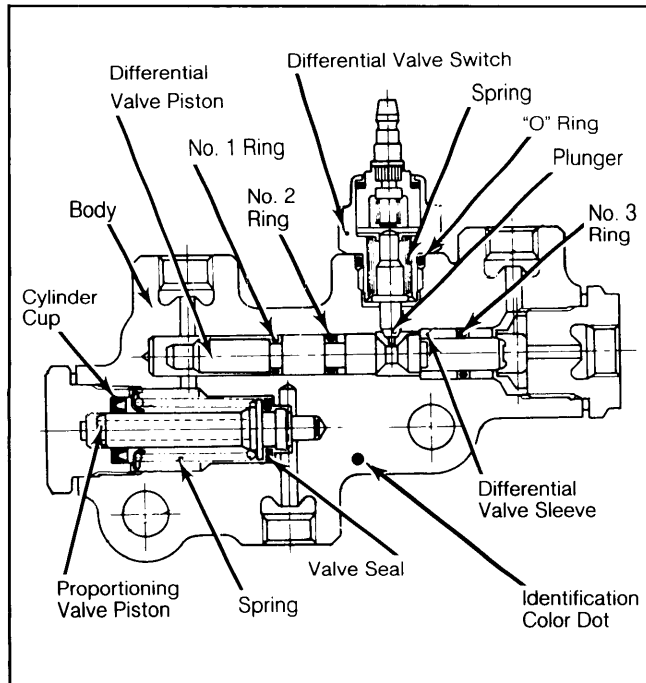

Challenger & Sapporo shown; others similar.

REMOVAL & INSTALLATION

FRONT DISC BRAKE PADS

Removal (Champ & Colt)

1) Raise and support vehicle. Remove front wheel. Remove protector by prying up edge of clip at center of protector. Hold center of "M" clip, detach "M" clip from pad and its ends from retaining pins. Remove clip.

2) Remove retaining pins from caliper, and remove "K" spring. Remove pads and anti-squeal springs from caliper by grasping backing plate area of pads with pliers.

Fig. 2: Installing Spring and Clip on Brake Pads

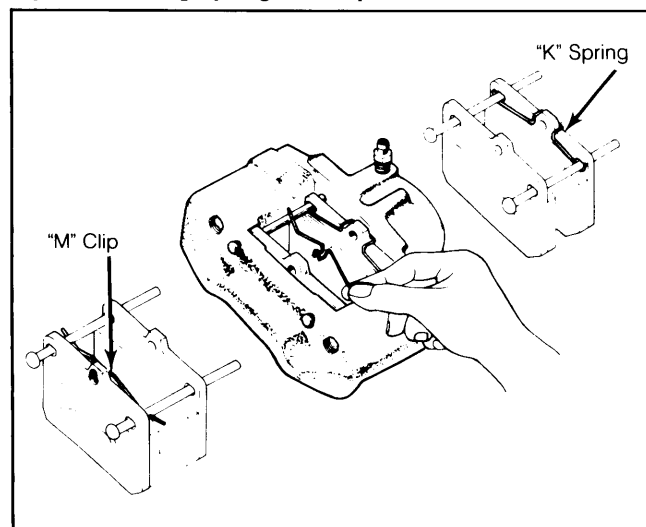

Illustration applies to Champ & Colt models.

NOTE: Replace all pads (left and right side) at same time.

Installation

Press piston to bottom of bore using a tool. Install disc pads and retaining pins. Install "K" spring and "M" clip, making sure positions are not reversed. See Fig. 2. Install pad protector with retaining clips on inner side of caliper.

Removal (All Other Models)

1) Raise and support vehicle. Remove front wheel. Remove retaining clip and pull out stopper plug. Loosen caliper assembly mounting bolts.

2) Pull caliper assembly up and down in a diagonal manner, and remove from mounting bracket. Remove inner and outer pad clips. Pull pads and anti-squeal shims from caliper support.

Fig. 3: Installing Pad Retaining Clips

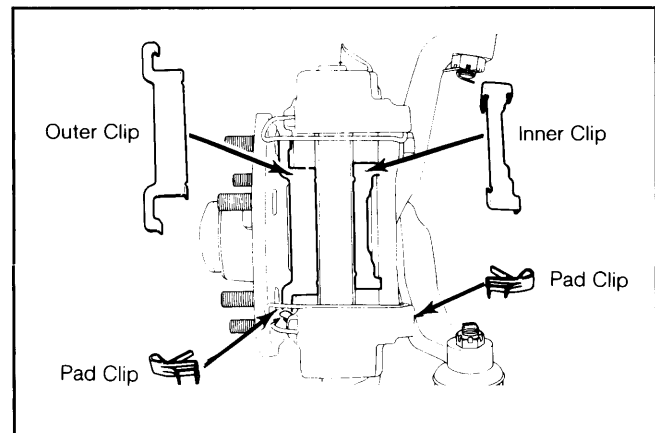

Illustration applies to Challenger, Sapporo & Pickups.

Installation

To install, reverse removal procedure and note the following: Press piston to bottom of caliper bore prior to pad installation. Ensure pad retaining clips are installed as shown in Fig. 3.

FRONT DISC BRAKE CALIPER

Removal (Champ & Colt)

Remove disc pads. Disconnect hydraulic line, and remove bolts attaching caliper assembly to steering knuckle. Remove caliper assembly.

Installation

Reverse removal procedure, tighten caliper mounting bolts to specification and bleed hydraulic system.

Removal (All Other Models)

Remove disc pads. Pull out hose clip from strut area, then disconnect brake hose from caliper. Remove caliper.

Installation

To install, reverse removal procedure, tighten caliper mounting bolts to specification and bleed brake system.

FRONT DISC BRAKE ROTOR

Removal (Champ & Colt)

1) Remove center cap, loosen drive shaft nut, lift vehicle, and remove wheels. Remove under cover. Remove lower arm ball joint and strut bar from lower arm.

CHRYSLER CORP. IMPORTS (Cont.)

2) Drain transaxle fluid, and remove caliper assembly. Insert pry bar between transaxle case and double offset joint outer case. To avoid damaging inner seal, do not insert pry bar more than .28" (7 mm). Push pry bar toward center of vehicle to remove drive shaft from transaxle.

3) Using an axle shaft puller (Special Tool No. CT-1003), force the drive shaft out of hub. Remove knuckle, hub and rotor as an assembly by removing 2 bolts attaching knuckle to strut assembly.

4) Mount steering knuckle in a vise, and drive out hub and rotor assembly with a soft hammer. Remove preload adjusting spacer from hub. Remove bolts attaching rotor to hub, and remove rotor from hub assembly.

Fig. 4: Removing Drive Shaft From Transaxle

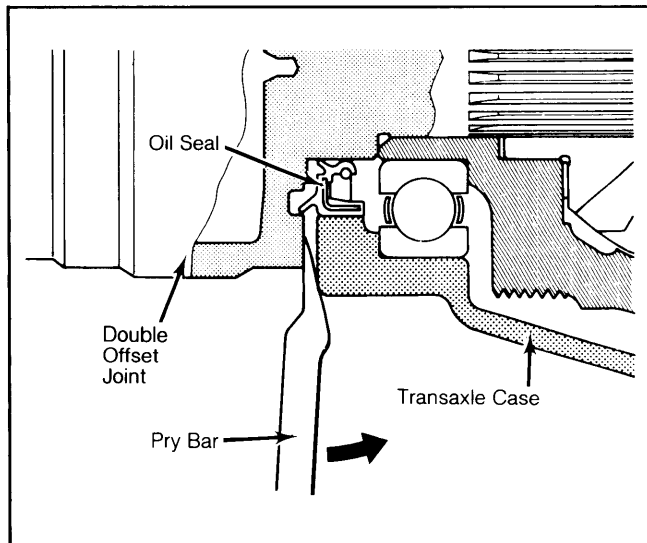

Champ & Colt model is shown.

Installation

1) Install rotor on hub, and tighten bolts to specification. Hold outer bearing inner race with Special Tool MB990776-A, and press hub into knuckle. Install new inner oil seal using Special Tools DT-1007-D and C-4171.

NOTE: It will take a force of approximately 4400 lbs. (1996 kg) to press hub assembly into knuckle.

2) Slide drive shaft into proper position, and install knuckle assembly by reversing removal procedures.

NOTE: If removal or replacement of bearings or races is necessary, see Chrysler Corp. Imports (FWD) article in SUSPENSION section.

Removal (All Other Models)

With caliper assembly removed, remove hub dust cap, cotter pin, lock nut (if used) and adjusting nut. Pull hub and rotor assembly from spindle using care not to drop outer wheel bearing. Remove hub-to-rotor attaching bolts, and separate rotor from hub.

Installation

To install, reverse removal procedures, and tighten hub-to-rotor bolts to specification. Bleed brake system if necessary, and adjust wheel bearings. See Chrysler Corp. Imports (FWD) article in SUSPENSION Section.

REAR DISC BRAKE PADS

Removal

1) Raise and support vehicle. Remove rear wheels. Remove caliper assembly dust cover. Disconnect parking brake cable from parking brake lever and from bracket.

2) Remove retaining pin and pull out stopper plug. Remove caliper assembly from rotor. Pull pads from caliper support.

Fig. 5: Positioning of Piston Stopper Groove On Rear Disc Brakes

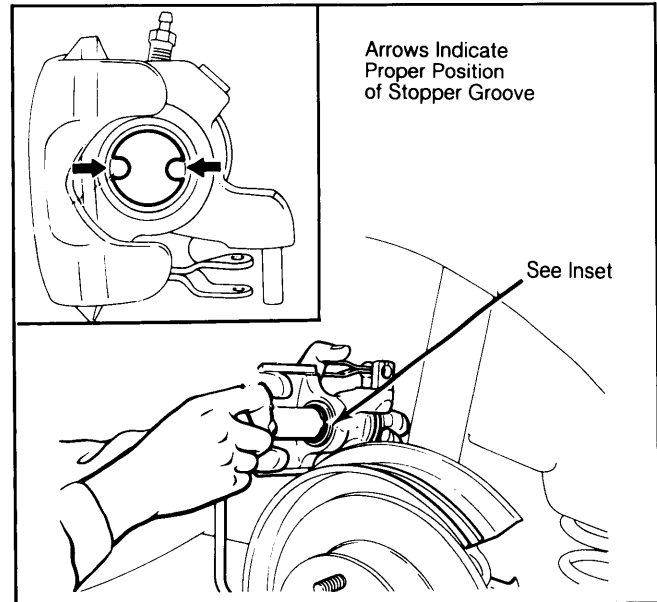

Installation

To install, reverse removal procedure, and note the following: Using a driver, press the piston into its original position with a clockwise rotation. Ensure piston stopper groove is positioned as shown in Fig. 5 so projection on back of pad will securely fit groove. Pad clips must be installed properly.

NOTE: DO NOT use a screwdriver to push piston into original position.

REAR DISC BRAKE CALIPER

Removal

Remove disc pads. Pull out hose clip from axle housing, and disconnect brake hose from caliper assembly. Remove clevis pin connecting lever assembly to parking brake cable. Then remove stopper plugs. Remove caliper assembly.

Installation

To install, reverse removal procedure, and bleed brake system.

REAR DISC BRAKE ROTOR

Removal

Remove disc pads. Remove caliper support-to-axle housing bolts. Remove caliper support. Remove rotor from axle shaft.

Installation

To install, reverse removal procedure, tightening bolts evenly.

Brakes

CHRYSLER CORP. IMPORTS (Cont.)

REAR BRAKE SHOES

Removal (Arrow Pickup & Ram-50 Pickup)

1) Raise and support vehicle. Remove brake drum, and remove return springs, adjusting spring and lever.

2) Remove shoes and adjuster as an assembly, and separate. Remove parking brake cable from lever.

Removal (Challenger & Sapporo)

1) Raise and support vehicle. Remove brake drum, and Remove hold-down springs. Disconnect strut-to-shoe spring and upper shoe return spring end from trailing shoe.

2) Remove trailing shoe and lower return spring. Hold adjuster latch down, pull adjuster lever toward center of brake.

3) Remove leading shoe assembly. Remove upper shoe return spring and strut-to-shoe spring.

Removal (Champ & Colt)

1) Raise and support vehicle. Remove brake drum, Remove clip spring, shoe return spring, shoe-to-shoe spring and hold-down spring.

2) Remove shoes and adjuster as an assembly and separate. Remove parking brake cable from lever.

Installation (All Models)

1) Reverse removal procedure, and note the following: Apply Lubraplate (or equivalent) to all shoe contact points, adjuster assembly, wheel cylinder, and parking brake lever pin. Adjust amount of engagement of adjusting lever with strut, only after pulling lever fully toward center of brake. Note that adjusting lever and latch spring differ between right and left sides.

2) Champ and Colt models require check of parking brake cable to ensure it will not advance brake lever when released. Adjuster will malfunction if lever advances.

3) Pickups require check of adjuster after installation is complete. Adjuster lever should mesh with

next tooth of adjuster when pulled, and return to original position after wheel has moved one tooth. Adjuster assemblies differ between right and left sides.

MASTER CYLINDER

Removal

Remove sensor connector (if equipped). Disconnect brake lines from master cylinder. Slowly depress brake pedal several times to drain fluid from cylinder housing. Remove master cylinder from booster unit and separate reservoirs from housing.

Installation

Reverse removal procedure. Prior to installation, check and adjust clearance between back of master cylinder piston and power brake push rod. Clearance should be 0-.03" (0-.75 mm) for Pickup models; .004-.020" (0.5-0.5 mm) for Challenger and Sapporo; and .006" (.015 mm) for Champ and Colt. Check and adjust pedal height, and bleed brake system after installation.

POWER BRAKE UNIT CHECK VALVE REPLACEMENT

NOTE: Test Check valve before removal. Pull off vacuum hose on booster side of check valve. Place finger over check valve, and crank engine. Vacuum should be felt.

Removal

Remove hose clamps from both ends of check valve. Remove check valve clamp and remove check valve.

Installation

Coat both ends of check valve with sealer and install valve with arrow (identification mark) pointing toward intake manifold side. Install check valve clamp and vacuum hoses, and secure hose clamps.

Fig. 6: Exploded View or Rear Brake Assembly for Component Relationship

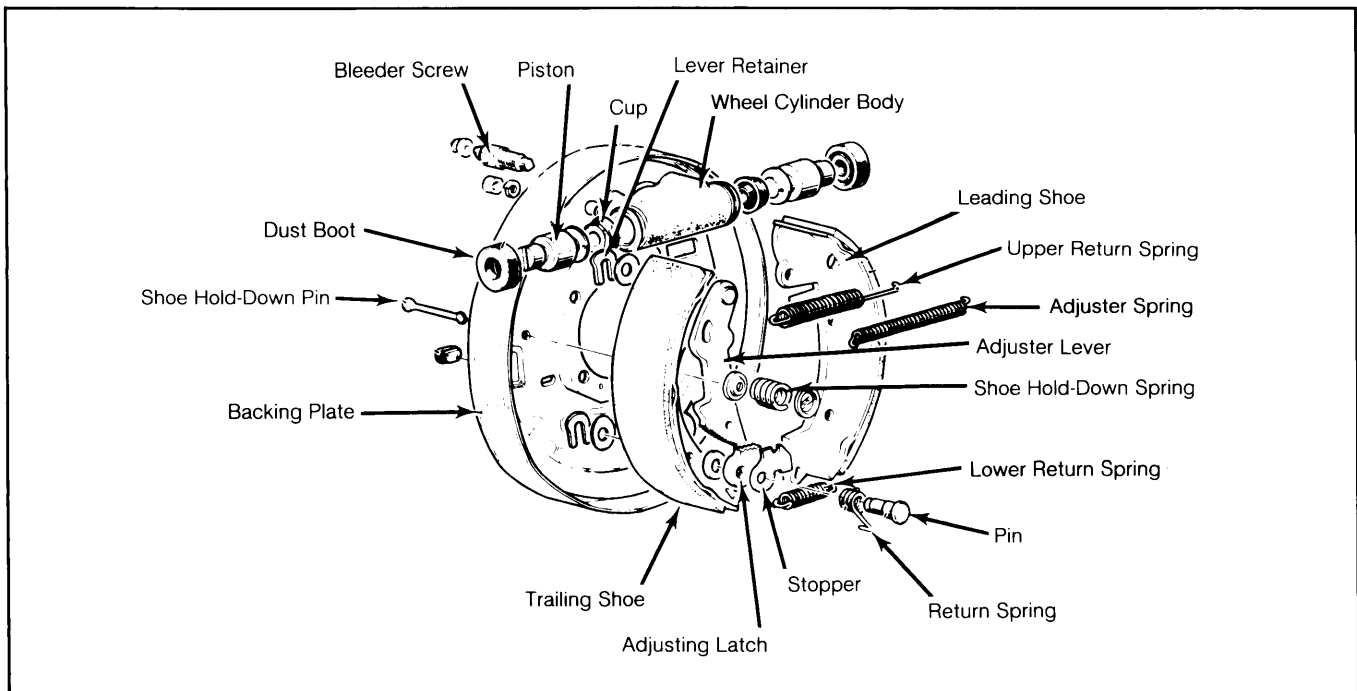

Challenger & Sapporo model is shown; other models are similar.

CHRYSLER CORP. IMPORTS (Cont.)

POWER BRAKE UNIT

Removal

Remove the brake master cylinder, and disconnect vacuum hose from power brake unit. Disconnect brake pedal and operating rod of power brake unit. Remove 4 nuts, attaching power brake unit to firewall from inside vehicle. Remove power brake unit.

Installation

Install power brake unit, and tighten nuts to specifications. Install brake master cylinder.

OVERHAUL

FRONT DISC BRAKE CALIPER

Disassembly (Champ & Colt)

Remove caliper attaching bridge bolts. Separate inner and outer caliper halves, and remove torque plate. Remove retaining ring and dust seal. Apply compressed air to fluid inlet to remove piston. Remove piston seal without damaging caliper bore or seal groove.

Fig. 7: Disassembled View of Disc Brake Caliper

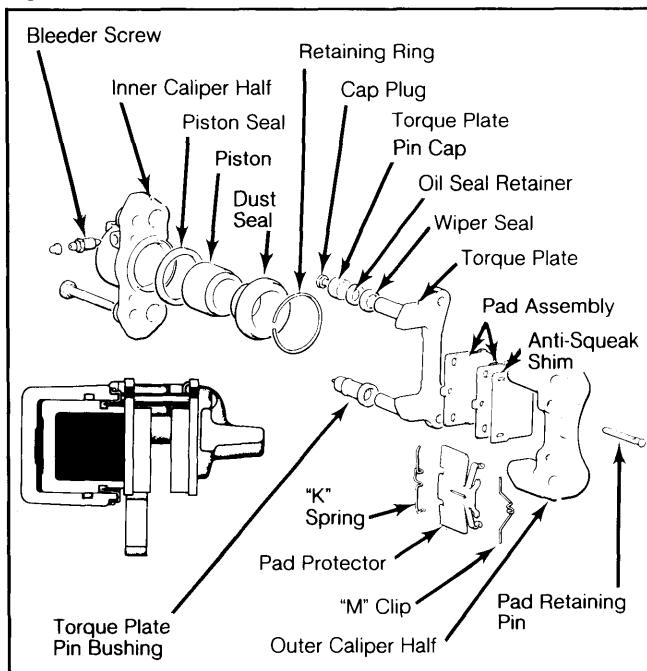

Illustration applies to Champ & Colt models only.

Cleaning & Inspection

Clean all metal parts in trichloroethylene, alcohol or brake fluid. Clean piston seal in brake fluid or alcohol; clean dust seal and other rubber parts in alcohol only. Inspect caliper bore and piston for wear, damage or rust. Replace parts as necessary. Always replace piston seal and dust seal.

NOTE: Repair kits contain proper lubricants to be used during reassembly.

Reassembly

Reverse disassembly procedure, and note the following: Apply rubber grease to piston seal. Apply brake fluid to piston when reassembling. If torque plate was removed from inner caliper half, clean torque plate shaft

and shaft bore in caliper. Apply special rubber grease to rubber bushing. Wipe seal inner surface and torque plate shaft before reassembly. Tighten bridge bolts of caliper halves.

NOTE: Possible cause of increased pedal stroke is: Insufficient fit between piston and piston seal. Correct by manually levering piston to seat several times. This will create a better fit between piston and seal. Make sure brake pad is removed during this procedure.

Disassembly (All Exc. Champ & Colt)

Remove dust boot. Apply compressed air to fluid inlet to remove piston. Remove piston seal without damaging caliper bore or seal groove.

Cleaning & Inspection

Clean all metal parts in trichloroethylene, alcohol or brake fluid; clean piston seal in alcohol or brake fluid. Clean dust boot and other rubber parts in alcohol only. Inspect caliper bore and piston for wear, damage or rust. Replace parts as necessary. Always replace piston seal and dust boot.

Reassembly

Coat piston seal with rubber grease. Slide seal into groove in cylinder bore. Slip piston into bore making sure seal is not twisted. Lightly coat dust seal groove with recommended rubber grease. Fit dust boot into place. Refit cylinder to caliper.

Fig. 8: Exploded View of Front Disc Brake Caliper

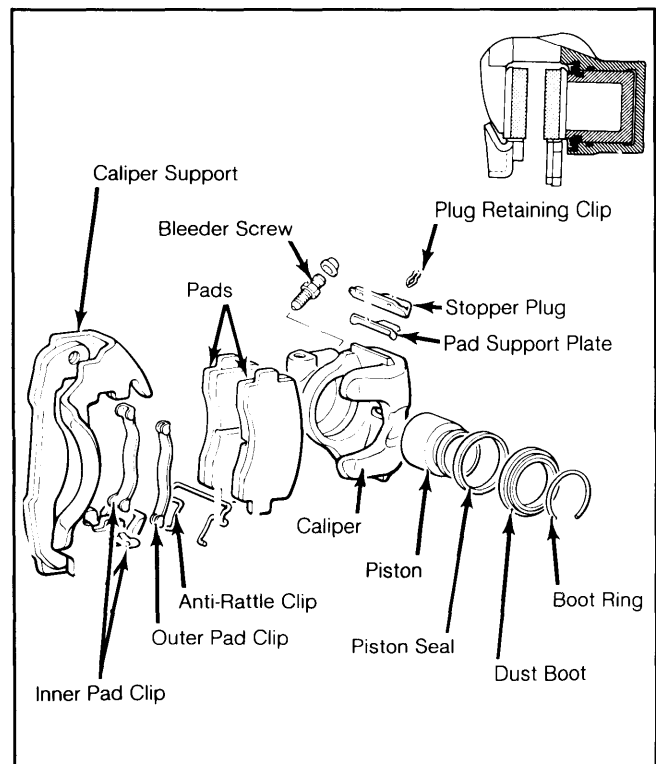

Caliper is for Challenger, Sapporo & Pickups.

REAR DISC BRAKE CALIPER

Disassembly

1) Remove cap ring, and take off lever cap. See Fig. 9. Remove retaining ring and spring. Pull out lever

Brakes

CHRYSLER CORP. IMPORTS (Cont.)

assembly. Slightly rotate automatic adjuster spindle, using pliers if necessary, and pull out assembly.

2) Using bearing remover tool (MB990665), pull bearings from caliper. Take off piston boot. Working through vacant area created by adjuster spindle removal, force piston out of caliper. Use a blunt tool to push out piston. Remove piston seal without damaging caliper bore or seal groove.

Cleaning & Inspection

1) Clean all metal parts in trichloroethylene, alcohol, or brake fluid. Clean piston seal and adjuster seal in alcohol or brake fluid. Clean piston boot and other rubber parts in alcohol only. Check cylinder and piston for wear, damage or rust. Replace worn parts as necessary. Always replace piston seal, adjuster seal, and piston boot.

2) Check bearings, connecting link, springs, adjuster spindle and lever assembly for wear, damage or rust. Check lever assembly for excessive play between shaft and bearing. Check staking of piston inner sleeve stopper plate. Ensure piston-to-automatic adjuster spindle clearance is .013-.017" (.33-.43 mm).

Reassembly

1) Lightly coat piston seal and piston with lubricant. Slide piston and seal into place, ensuring seal does not twist in groove. Lubricate boot, and slide boot into position making sure it engages groove in cylinder bore.

NOTE: Repair kit includes recommended lubricants.

2) Using bearing installation tool (MB990665), press in bearings until ends are flush with caliper body. Make sure mark on end of bearing faces out.

3) Coat automatic adjuster seal with recommended grease. Fit adjuster spindle and hardware in place until spindle turns freely. Make sure spring faces proper direction.

4) Press in connecting link spring washers with tool (MB990666). Fit automatic adjuster spindle into place (spindle is not a press fit). Insert connecting link and lever assembly.

5) Fill lever cap with Niglube RX-2 (or equivalent), making sure all areas have significant amount of grease. Lightly grease stopper plug and caliper sliding surface. Assembly is ready for installation.

MASTER CYLINDER

Disassembly

1) Remove dust boot, retaining ring, stop washer and piston stop bolt. Withdraw primary piston assembly, secondary piston assembly and secondary return spring from master cylinder.

2) Remove check valve caps, tube seats, check valves and check valve springs. Champ and Colt Hatchback master cylinders are equipped with 2 identical check valves.

NOTE: DO NOT disassemble primary and secondary piston assembly.

Cleaning & Inspection

Check master cylinder bore and piston for wear or other damage. Replace as necessary. Check clearance between cylinder bore and piston. If clearance exceeds .006" (.15 mm), replace parts as necessary. Check all parts of primary and secondary piston assem-

Fig. 9: Exploded View of Rear Disc Brake Caliper Assembly

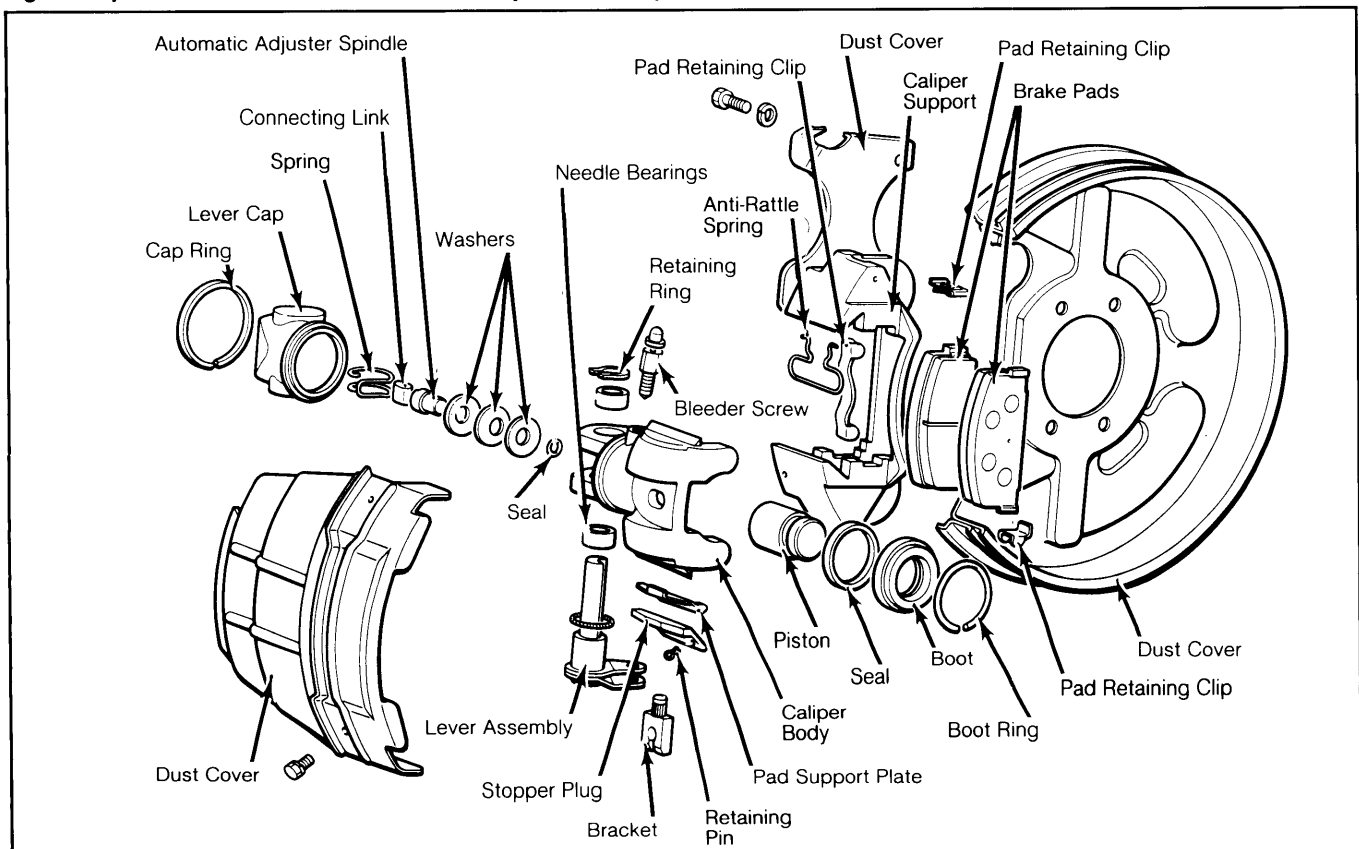

CHRYSLER CORP. IMPORTS (Cont.)

Fig. 10: Disassembled View of Master Cylinder

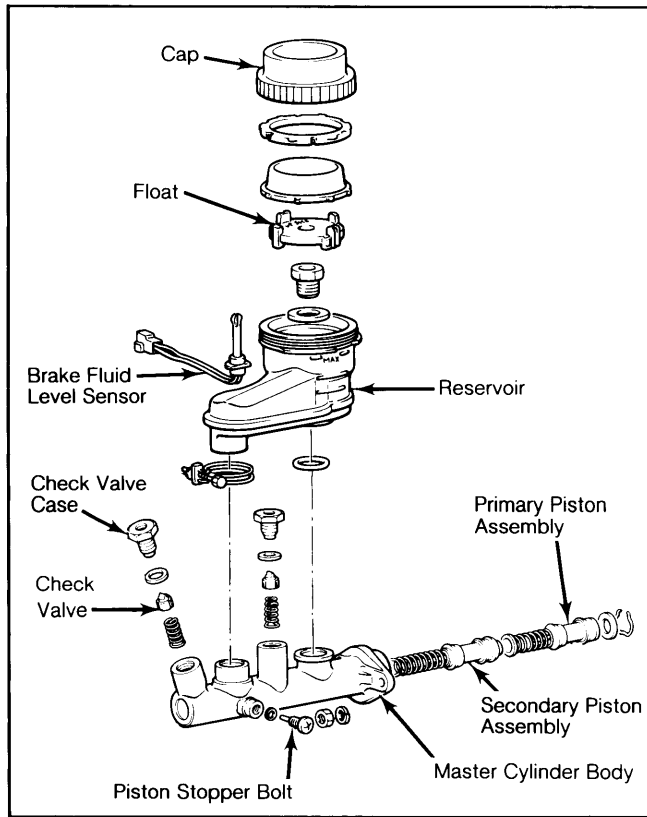

Champ & Colt models shown; others similar.

blies and piston cups and springs. If any parts are found defective, replace components as assemblies.

Reassembly

Reverse disassembly procedure and note the following: Before reassembly, apply rubber grease to all parts (except boots). When assembled, check that return port is not blocked by piston cup, when piston is at return position.

NOTE: Check valves differ between rear disc and rear drum models. Be sure correct check valve is properly installed.

TIGHTENING SPECIFICATIONS

Application	Torque Ft. Lbs. (N.m)
Rotor to Hub Bolts	
Challenger & Sapporo	25-29 (34-39)
Champ & Colt	29-36 (39-49)
Pickup Models	34-38 (46-51)
Caliper Mounting Bolts	
Challenger & Sapporo	51-65 (69-88)
Champ & Colt	43-58 (59-78)
Pickup Models	51-65 (69-88)
Caliper Bridge Bolts	
Champ & Colt Only	58-69 (78-93)
Front Wheel Drive Components	
Drive Shaft Nut	87-130 (118-177)
Knuckle-to-Strut Assy.	54-65 (74-88)
Lower Arm-to-Ball Joint	69-87 (93-118)
Lower Arm-to-Strut Bar	69-87 (93-118)
Knuckle-to-Tie Rod	11-25 (15-33)

DISC BRAKE ROTOR SPECIFICATIONS

Application	Disc Diameter In. (mm)	Lateral Runout In. (mm)	Parallelism In. (mm)	Original Thickness In. (mm)	Min. Refinish Thickness In. (mm)	Discard Thickness In. (mm)
Arrow Pickup & Ram-50 Pickup006 (0.15)79 (20.1)72 (18.4)
Challenger & Sapporo Front	10.04 (255)	.006 (0.15)49 (12.5)43 (11.0)
Rear (Optional)	9.72 (247)	.006 (0.15)39 (10.0)33 (8.4)
Colt & Champ006 (0.15)51 (13.0)45 (11.4)

DRUM BRAKE SPECIFICATIONS

Application	Drum Diam. In. (mm)	Drum Width In. (mm)	Max. Drum Refinish Diam. In. (mm)	Brake Cyl. Diam. In. (mm)	Master Cyl. Diam. In. (mm)
Arrow Pickup & Ram-50 Pickup	9.5 (241.3)	9.58 (243.3)	3/4 (19.05)	7/8 (22.22)
Challenger & Sapporo	9.0 (228.6)	9.08 (230.6)	13/16 (20.64)	7/8 (22.22)
Colt & Champ	7.1 (180)	7.20 (182)	3/4 (19.05)	13/16 (20.64)