

BMW

320i, 528e, 633CSi, 733i

DESCRIPTION

Brake system is hydraulically-operated, using a tandem master cylinder and power brake unit. All models except 320i are equipped with 4 piston ATE front and rear disc calipers. The 320i is equipped with rear drum brakes and 2-piston Girling front disc brake calipers.

Disc pad wear indicators are mounted on the instrument panel of 320i and 528e models to indicate need for pad replacement. On 633CSi and 733i models, pad wear indicator lamp is component of "Check Control" system.

An optional brake pressure regulator may be installed to reduce fluid pressure to rear brakes. Parking brake is cable-actuated on drum brake of 320i, and consists of internally-mounted parking brake shoes on all rear disc brake systems.

ADJUSTMENT

REAR DRUM BRAKE SHOES

320i

Raise and support vehicle. Release parking brake. While rotating tire, tighten brake adjusters. Turn left adjuster counterclockwise and right adjuster clockwise until brake shoes lock drum. Loosen each adjuster 1/8 turn or until wheel rotates without drag.

BRAKE PEDAL HEIGHT

1) Brake pedal height (measured from firewall to pedal pad center) should be 9.4-9.8" (239-249 mm) on 320i; 9.1-9.5" (230-241 mm) on 528e and 633CSi; and 9.9-10.2" (251-260 mm) on 733i.

2) To adjust pedal height, loosen stop light switch lock nut, and position stop light switch out of way. Loosen brake operating rod lock nut, and turn operating rod until correct pedal height is obtained. Tighten lock nut, reposition, adjust stop light switch, and tighten stop light switch lock nut.

STOP LIGHT SWITCH

Stop light switch is located under instrument panel in front of brake pedal arm. To adjust stop light switch, loosen lock nut. Turn adjusting nut so contact plunger just touches pedal arm and extended length of plunger is .20-.24" (5-6 mm). Tighten lock nut.

PARKING BRAKE

NOTE: Before adjusting parking brake (except 320i), pull parking brake lever until resistance is felt; then 1 additional notch. With parking brake lever engaged as described, drive vehicle a maximum of 1/4 mile.

Except 320i

1) Raise and support vehicle. Remove tire and wheel, and release parking brake. Insert a screwdriver into rotor inspection hole. Turn adjuster until parking brake shoes lock rotor. Back off adjuster 4-6 notches.

2) Working inside driver's compartment, tighten adjustment nuts on lever until parking brake holds vehicle securely before fifth ratchet stop is reached.

320i

1) Raise and support rear of vehicle. Fully release parking brake. Tighten brake shoes until wheel is locked. Back off adjusters about 1/8 turn or until wheel can just barely turn.

2) Work inside passenger compartment and tighten nuts on lever until parking brake holds vehicle securely before fifth ratchet stop is reached.

BRAKE WARNING LIGHT

1) A dual warning light is mounted on instrument panel. Light should glow when parking brake lever is pulled 1 notch (ignition on) and go off when lever is fully released.

2) To check circuit warning sensor, fully release parking brake, and ensure light is off (ignition on). Raise master cylinder filler cap. Warning lamp should glow. If not, check bulb or circuit connections.

REMOVAL & INSTALLATION

DISC PADS

Removal

Raise and support vehicle. Remove wheel and tire. Disconnect pad wear sensors. Bend open fastener, and pull out. Drive out retaining pin toward inside of vehicle. Remove cross spring. Using extractor tool, remove pads from caliper. If pad thickness has worn to .080" (2 mm), replace pads. Only replace pads in matched sets.

Installation

1) Using a cylinder brush, clean guide surface and support surface in caliper. Siphon sufficient fluid from master cylinder reservoir to prevent overflowing. Press pistons to bottom of bores.

2) On rear calipers, ensure machined position of piston face makes a 20° angle with caliper wall. See Fig. 1. Rotate piston with tool 341050 if necessary. On all calipers except 320i front calipers, install disc pads, shims (if required), cross spring and retaining pins. After installation, depress brake pedal several times to seat pads.

3) On 320i calipers, adjust shoulders of pistons so that guards are located at machined shoulders of piston. If necessary, use guard as adjusting template.

Fig. 1: Piston Alignment for Rear Brake Calipers

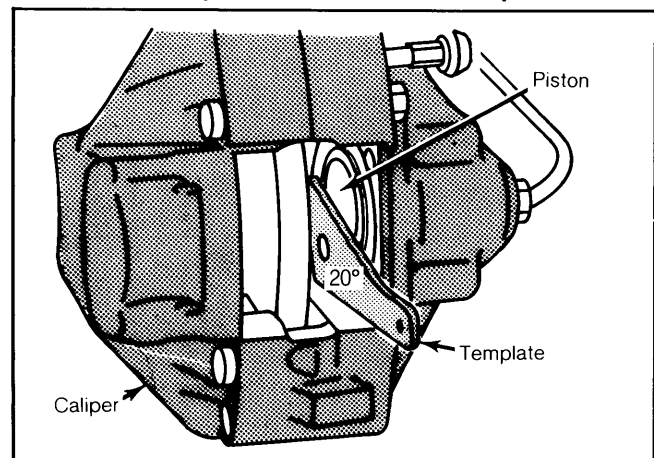

Use template to achieve 20° angle.

Brakes

BMW (Cont.)

Install pads, cross spring, and retaining pins. Replace fastener, bending straight side. After installation, depress pedal several times to seat pads.

CALIPER ASSEMBLY

Removal

Drain brake fluid from master cylinder reservoir. Remove caliper mounting bolts. Disconnect disc pad wear indicator electrical lead. Disconnect brake fluid inlet lines. Lift caliper off rotor.

Installation

Reverse removal procedure and then bleed the hydraulic system.

ROTOR

Removal

Raise and support vehicle. Remove tire and wheel. On front calipers, separate bracket from strut. On all models, remove caliper, and hang from frame with wire. DO NOT disconnect hydraulic line. On rear calipers, slip hydraulic line out of holding clamp. Remove rotor mounting bolt, and remove brake rotor.

NOTE: Front brake rotors are balanced. DO NOT remove or reposition balance clips. If any rotor must be replaced, replace rotors in axle sets.

Installation

To install, reverse removal procedure.

PARKING BRAKE SHOES

Removal

With rear caliper and rotor removed, disconnect lower return spring using brake spring pliers. Using brake spring removal tool, turn retaining springs 90°. Set spring aside. Pull brake shoes apart at bottom and lift upward.

Installation

To install, reverse removal procedure, adjust parking brake shoes, and check operation.

BRAKE DRUM

Removal & Installation

Loosen brake adjuster cams. Remove countersunk Allen bolt, and slide off brake drum. To install,

Fig. 2: Exploded View of 320i Rear Drum Brake Assembly

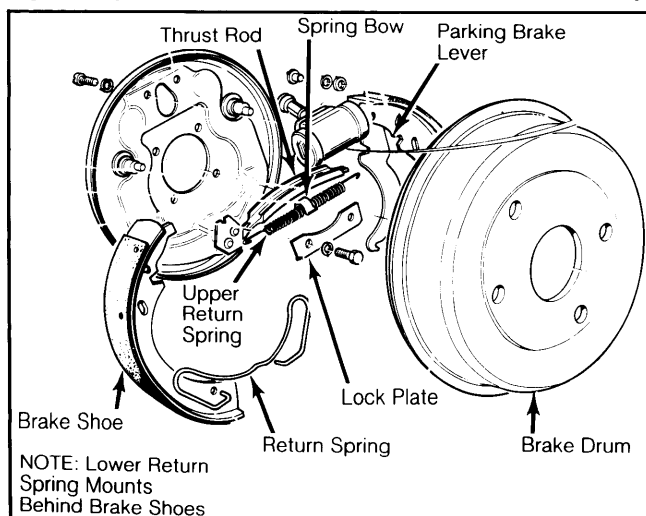

reverse removal procedure and note: If one brake drum is reground, drum on other side must also be reground.

BRAKE SHOES

Removal

Remove brake drum. Disengage mounting spring and hold-down spring clip from each shoe. Disconnect bottom return spring. Pull shoes apart and out of each wheel cylinder. Disconnect parking brake cable, and remove brake shoes. If brake shoe lining has worn to .118" (3.0 mm) or less, replace brake shoes.

Installation

Reverse removal procedure and note: Connect long end of spring between parking brake lever and brake shoe.

MASTER CYLINDER

NOTE: On 320i models only, mixture control unit must be removed to take off master cylinder.

Removal

1) Siphon off brake fluid from reservoir. On 320i, disconnect clutch hose connection. On 633CSi, remove air cleaner. On 528e and 633CSi, remove relay holder attaching bracket with all components still attached, and position out of way.

2) Disconnect all hydraulic lines from master cylinder. Remove nuts mounting master cylinder to power booster. On 320i models, remove nuts mounting master cylinder support to inner fender panel. Remove support and master cylinder.

Installation

To install, reverse removal procedure and note: Make sure "O" ring on master cylinder is not damaged. An imperfect fit will not allow correct vacuum build-up.

POWER BRAKE UNIT

NOTE: Power brake unit must be removed with master cylinder attached. On 320i, mixture control unit must be removed prior to removal of power brake unit.

Removal

1) Siphon brake fluid from master cylinder reservoir. On all models except 320i, remove left portion of lower dash panel. On all models, remove operating rod clevis pin from brake pedal arm. On 633CSi, remove air cleaner. On 528e and 633CSi, remove relay holder as previously described.

2) Disconnect and plug hydraulic lines at master cylinder, including clutch hose. Disconnect vacuum hose from power brake unit (hydraulic lines on 733i). Remove power brake unit mounting bolts. On 320i only, separate master cylinder support from inner fender panel. Remove power unit/master cylinder assembly from vehicle. Separate master cylinder from power brake unit.

NOTE: On 733i models only, power steering pump also supplies hydraulic pressure through hydraulic accumulator to the power brake unit. If power steering fails, there will be sufficient pressure in the hydraulic accumulator to provide a few brake applications with full power.

BMW (Cont.)

Installation

To install, mount master cylinder to power brake unit, and reverse removal procedure. Bleed hydraulic system after installation.

Check Valve Replacement (Exc. 733i)

Check valve is located in vacuum line between power unit and intake manifold. To remove, loosen hose clamps, remove vacuum lines, and remove valve. To install, reverse removal procedure. Make sure arrow or black portion of valve faces intake manifold.

Filter Replacement (Exc. 733i)

With power brake unit removed from vehicle, pull back rubber dust boot. Remove retaining ring. Remove silencer and filter. To install, reverse removal procedure.

OVERHAUL

BRAKE CALIPER

NOTE: DO NOT disassemble 4-piston caliper halves.

Disassembly

With pads removed from caliper, remove retaining ring and dust boot. Using clamp, hold one piston in position, and insert wooden block in caliper cavity. Apply compressed air to fluid inlet to force out opposite piston. Repeat procedure for each piston. Remove piston seals without damaging caliper bore.

Fig. 3: Disassembled View of 2-Piston Caliper

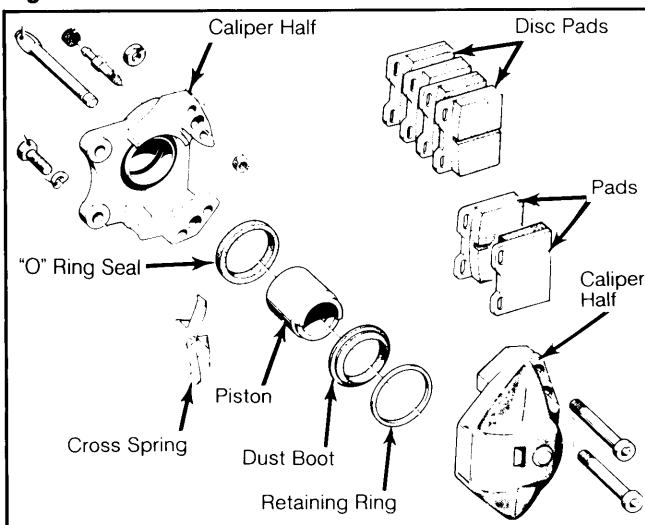

Caliper is used as rear caliper on 528e, 633CSi, and 733i models and front caliper on 320i models only.

Cleaning & Inspection

Clean components in clean brake fluid, and blow dry. Inspect caliper bore and pistons for wear or damage. Replace caliper assembly if corroded or worn. DO NOT hone. Replace piston seals and dust boots at each overhaul.

Reassembly

Coat pistons and calipers bores with brake cylinder paste. Install piston seals, then install pistons. Make sure pistons are not tilted when inserting. On 2-piston calipers, ensure 20° piston angle is preset. Install dust boots and retaining rings.

Fig. 4: Disassembled View of 4-Piston Caliper

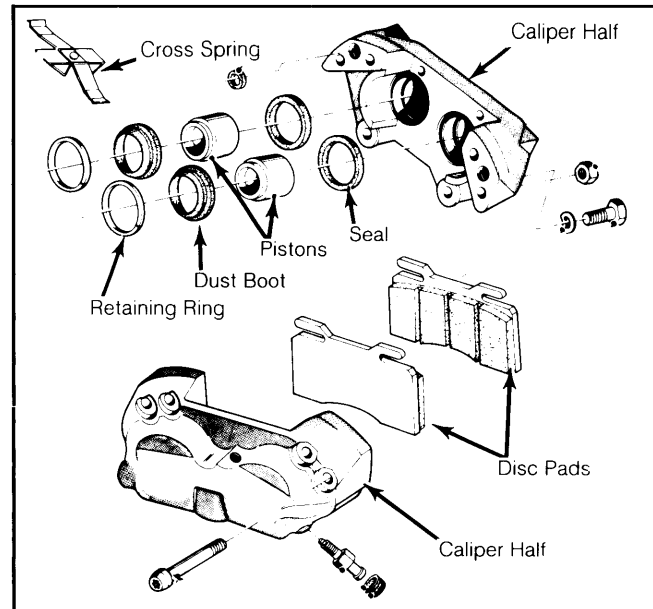

Caliper is used as front caliper on 528e, 633CSi, & 733i.

REAR WHEEL CYLINDER

Disassembly

Remove dust boots and force out pistons and return spring. Separate and discard cylinder cups from pistons.

Cleaning & Inspection

Clean all parts in clean brake fluid. Check cylinder bore and dust boot retaining grooves for rust and corrosion. Replace wheel cylinder assembly if defective. DO NOT hone. Replace all rubber parts during overhaul.

Reassembly

Coat all parts with brake cylinder paste. Reassemble wheel cylinder by reversing disassembly procedure.

Fig. 5: Exploded View of 320i Rear Wheel Cylinder

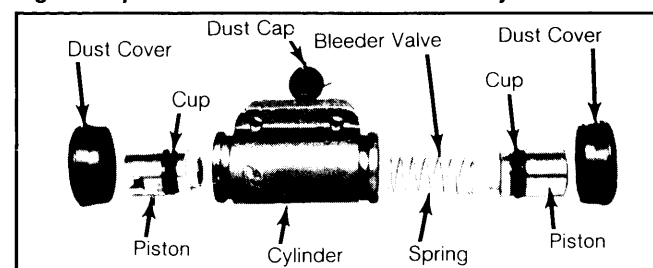

MASTER CYLINDER

NOTE: All master cylinders are similar. Procedures outlined are general.

Disassembly

Push in on primary piston, and remove secondary piston stop screw. Remove snap ring from end of cylinder, and remove primary and secondary piston assemblies and return spring. Disassemble piston assemblies, noting number and position of parts used.

Brakes

BMW (Cont.)

Cleaning & Inspection

Clean all parts in alcohol and inspect for wear or damage. Master cylinder bore diameter is .812" (20.64 mm) on 320i; .938" (23.81 mm) on 528e and 633CSi; and .875" (22.23 mm) on 733i.

Fig. 6: Master Cylinder Primary Piston Assembly

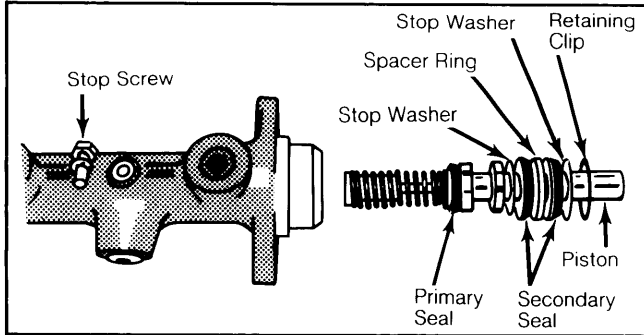

NOTE: Cylinders with surface defects in bores must be replaced. Do not overhaul.

Reassembly

Reassemble piston assemblies using thin coating of ATE brake paste. Install piston assemblies into cylinder bore, using a guide sleeve to prevent damage to

seals. Install secondary piston stop screw, making sure piston is pushed fully forward before screw is installed and tightened. Install retaining ring in end of master cylinder bore.

Fig. 7: Master Cylinder Secondary (Front) Piston Assy.

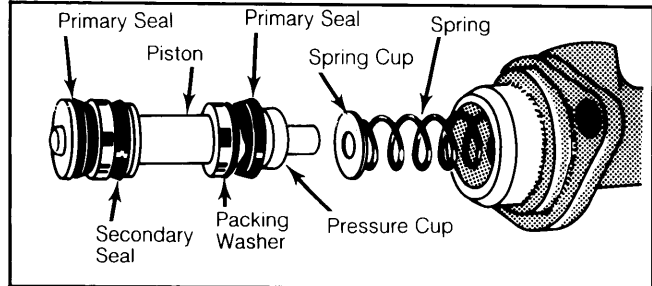

TIGHTENING SPECIFICATIONS

Application	Ft. Lbs. (N.m)
Caliper Mounting Bolts	
Front	58-69 (79-94)
Rear	43-48 (58-65)
Rotor-to-Wheel Hub	
528e & 633CSi	11-13 (15-18)
733i	23-24 (30-33)
320i	36-42 INCH Lbs. (4-5 N.m)

DISC BRAKE ROTOR SPECIFICATIONS

Application	Disc Diameter In. (mm)	Lateral Runout In. (mm)	Parallelism In. (mm)	Original Thickness In. (mm)	Min. Refinish Thickness In. (mm)	Discard Thickness In. (mm)
320i Front008 ¹ (.2)	.0008 (.02)	.500 (12.7)	²	.461 (11.7)
528e Front008 ¹ (.2)	.0008 (.02)	.866 (22)	²	.827 (21)
Rear008 ¹ (.2)	.0008 (.02)	.374 (9.5)	²	.334 (8.5)
633CSi Front008 ¹ (.2)	.0008 (.02)	.866 (22)	²	.827 (21)
Rear008 ¹ (.2)	.0008 (.02)	.748 (19)	²	.709 (18)
733i Front006 ¹ (.15)	.0008 (.02)	.866 (22)	²	.827 (21)
Rear006 ¹ (.15)	.0008 (.02)	.394 (10)	²	.354 (9)

¹ — Installed on vehicle.

² — Matching of each braking surface is .020" (.5 mm). Discard rotor thickness must be observed.

DRUM BRAKE SPECIFICATIONS

Application	Drum Diam. In. (mm)	Drum Width In. (mm)	Max. Drum Refinish Diam. In. (mm)	Brake Cyl. Diam. In. (mm)	Master Cyl. Diam. In. (mm)
320i Rear	9.84 (250)	9.88 (251)	3/4 (19.05)