

VOLVO POWER-ASSISTED RACK & PINION

DESCRIPTION

Power steering is rack and pinion type. Some models use a Volvo cam gear type with aluminum housing. Other models use a ZF model with removable valve housing.

Steering consists of the rack and pinion steering gear and a power-assist pump interconnected with flexible lines. A separate reservoir is attached to the Saginaw pump.

LUBRICATION

CAPACITY

DL, GL, GLT, GLT Turbo, Diesel .8 qts. (.76L)
GLE 1.3 qts. (1.24L)

FLUID TYPE

ATF (Automatic Transmission Fluid)

STEERING GEAR FILLING

Remove inner clamp on right side rubber bellows, and using a suction gun, fill gear with recommended lubricant through side of bellows. Reinstall clamp. Carefully compress bellows so some fluid will flow to other side.

HYDRAULIC FLUID FILLING

Fill the reservoir with approved fluid, start engine and allow to idle, adding fluid as level drops.

ADJUSTMENTS

HYDRAULIC FLUID BLEEDING

1) Fill the reservoir with approved fluid, start engine and allow to idle, adding fluid as level drops. Turn steering wheel from lock-to-lock in a slow even motion to allow the pump to operate at low pressure.

2) Continue turning steering wheel until fluid in reservoir is almost free of air bubbles. Check that fluid is at the level mark. Install reservoir cap.

SERVO BALANCE TESTING & ADJUSTING

Testing

1) Connect a pressure gauge between steering pump and steering gear. See Fig. 1. Make sure fluid in reservoir is at level mark. Place pressure gauge so it can be seen from the driver's seat.

2) Remove steering wheel impact guard by compressing sides slightly. Install a torque wrench on steering wheel nut.

3) With engine at idle, turn steering wheel (using torque wrench) slowly to the right. Read torque when pressure reaches 170 psi (12 kg/cm²) on cam gear type, 285 psi (20 kg/cm²) for ZF steering gear.

4) Repeat operation turning wheel to left. Torque should be 2.5-3.0 ft. lbs. (3.4-4.5 N.m) as gear approaches specified pressure.

5) Difference between both sides must not exceed .7 ft. lbs. (.9 N.m) on cam gear type. Difference must not exceed .36 ft. lbs. (.5 N.m) on ZF steering gear.

6) If difference exceeds this amount, cam gear type can be corrected following adjustment procedure.

Fig. 1: Pressure Gauge Test Set Up

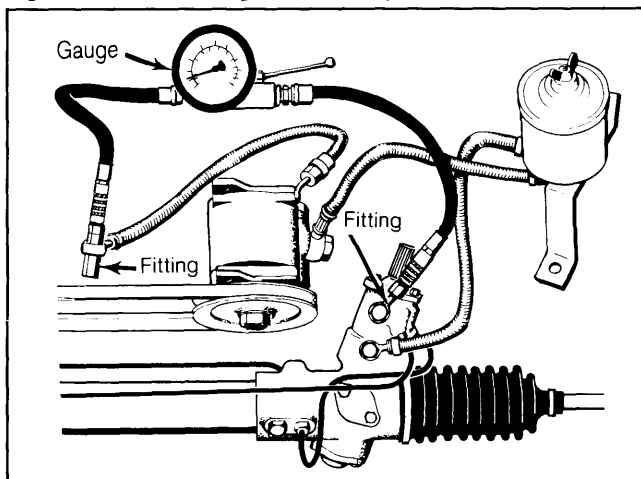

Make sure fluid level is at full mark when testing.

Adjusting (Cam Gear Type)

1) Turn off engine and remove lock nut and washer from lower pinion bearing. Lock washer will have 1 tab bent down to lock adjustment nut (bearing race). See Fig. 2.

Fig. 2: Adjusting Lock Washer on Cam Gear Type Power Steering

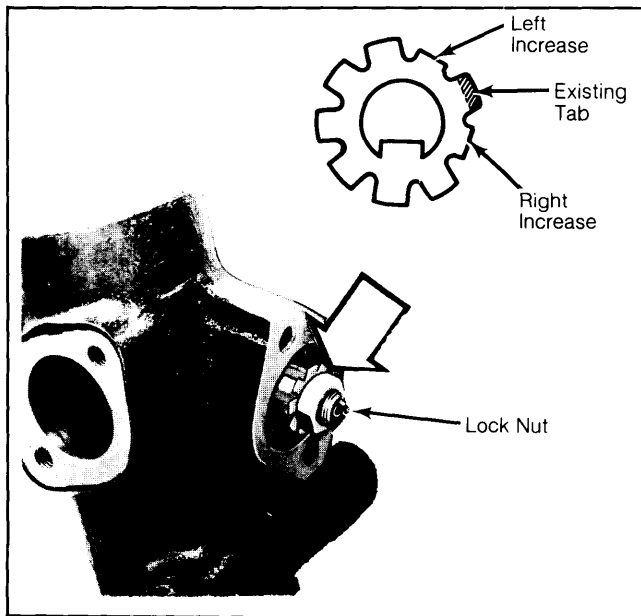

Only 1 tab should be bent down to lock adjustment nut.

2) To increase torque for left side, straighten existing bent tab and bend first tab to left. To increase torque for right side, bend first tab to right.

NOTE: Changing tabs increases the amount of torque for one side and decreases the torque on the other side. The value of torque increase or decrease is 4 INCH lbs. (.45 N.m).

3) After bending tab, use spanner wrench (99 95 049) to turn adjustment nut until groove fits lock washer tab. Reinstall lock washer and lock nut. Install pinion cover and gasket.

Power Steering

VOLVO POWER-ASSISTED RACK & PINION (Cont.)

REMOVAL & INSTALLATION

STEERING GEAR

Removal

1) Remove lock bolt and nut from pinion flange. Bend flange apart slightly. Raise vehicle and support with safety stands. Remove wheel assemblies.

2) Remove tie rod nuts and disconnect ball studs from spindle using ball joint removal tool (5043). Remove splash guard.

3) Disconnect hoses at steering gear and install plugs in hose connections to protect against contamination.

4) Remove bolts retaining steering gear to front axle member. Pull steering gear down until free of steering shaft flange. Remove steering gear on left side of vehicle.

Installation

1) To install, reverse removal procedures. Make sure recess on pinion shaft is aligned toward lock bolt opening in flange.

2) Install right side "U" bolt and flange, but do not tighten. Install and tighten left side bolts. Tighten right side "U" bolt.

3) Connect steering rods. Make sure rods are same length. Difference should not exceed 1/16" (2 mm). Install lock bolt on flange and reconnect hoses.

POWER STEERING PUMP

Removal

Remove pivot bolts on bracket and bolt on belt tensioning bracket. Place a container below pump to receive drained fluid, disconnect hydraulic connections at pump, remove pump.

Installation

To install, reverse removal procedures. Fill and bleed the system.

OVERHAUL

STEERING GEAR

Disassembly (Cam Gear Type)

1) Remove hose clamps holding rubber bellows. Cut clamps and remove equalizer tube and 2 pressure tubes. Attach steering gear to fixture (5046) and fasten with "U" bolt.

2) Drain fluid from rack by slowly turning pinion back and forth in full strokes. Place rack in center position. Check inner and outer ball joints for excessive wear.

3) Remove outer clamp and pull back boot. Clean grease from rack and ball joint areas. Using a spanner and adjustable wrench, remove left steering rod. Loosen right side rod.

Fig. 3: Exploded View of Cam Gear Type Power Steering Assembly

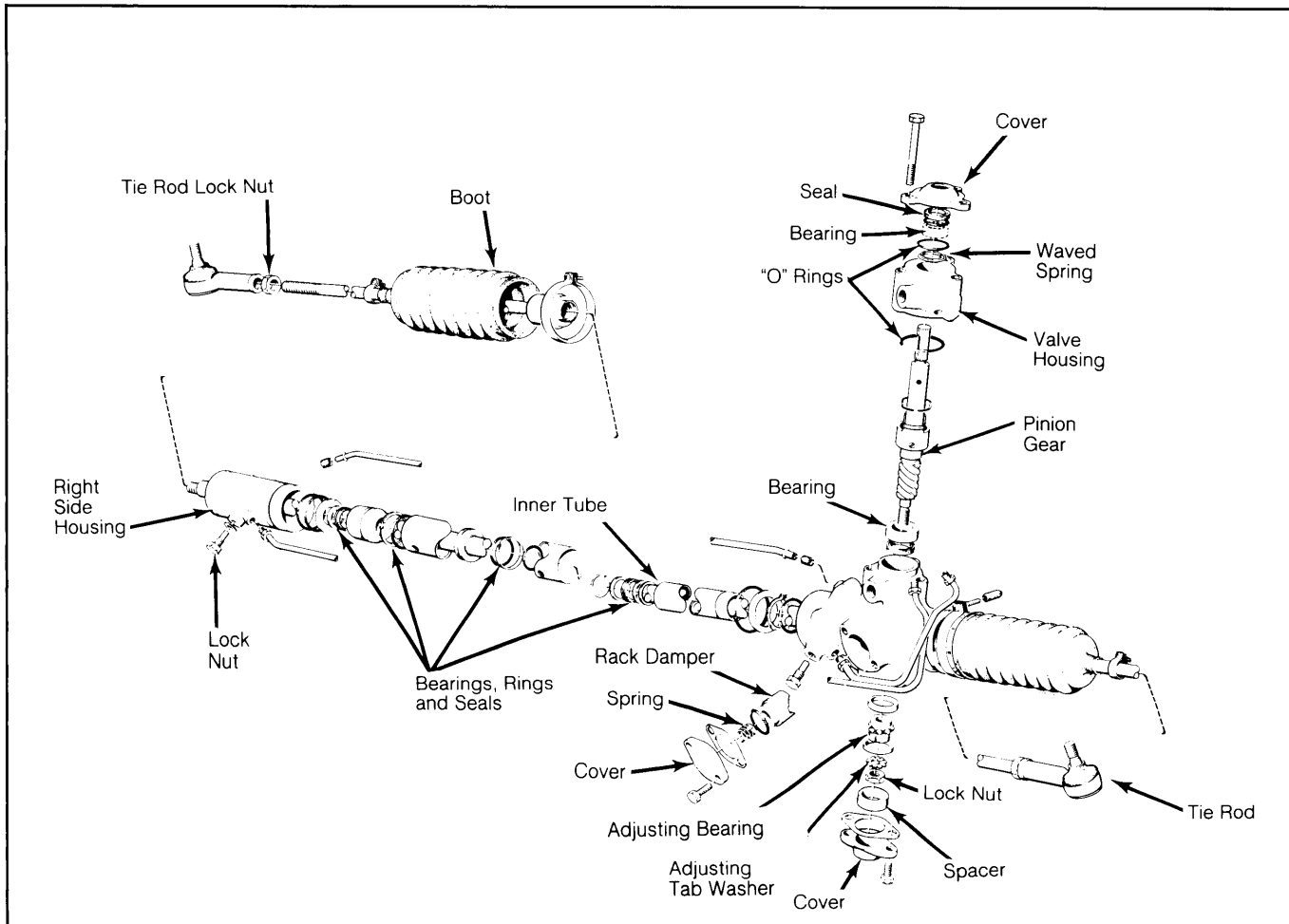

VOLVO POWER-ASSISTED RACK & PINION (Cont.)

4) Remove locking wire for cage on right side. Turn end housing clockwise. Wire will protrude through tube. Hold pinion stationary and apply compressed air to remove end housing and bushing.

5) Remove right steering rod. Remove end housing plastic ring and bushing. Remove cover, shims, spring and piston of pre-tension device. Remove pinion lock cover, lock washer and gaskets.

6) Using a hook spanner, remove spacer (inner) sleeve. Bend back lock washer, hold pinion shaft and remove nut. Valve should not move. Remove inner bearing race, ball cage and lower race using sleeve (5049).

7) Remove dust seal, valve housing cover, and "O" ring. Remove spring, valve housing and pinion gear. Remove "O" ring. Carefully pull out rack on right side. Remove upper bushing and seal for pinion gear using extractor (1819).

8) If damaged, remove inner race for pinion bearing using 2 screwdrivers. Carefully tap out rack rod seal ring and spacer sleeve from steering gear tube.

NOTE: Ensure that inner surface of tube is not damaged by scratches.

9) Use a 1 1/16" (27 mm) socket and 2 long extensions inserted through housing. Place bearing in soft-jawed vise and pry out seal. If damaged, or if vehicle has been driven more than 25,000 miles, remove seal ring.

Inspection

1) Clean all parts. Inspect for wear or damage. If pinion control valves or housing are damaged, parts should be replaced as an assembly.

2) Should right rack bushing require replacement, complete rack sleeve should be replaced. Replace all seals, "O" rings, and valve housing cover when reassembling.

Reassembly

1) Install seal and "O" ring to right side rack sleeve. Seal lips should face down. Lubricate seal lips before installation and use a socket to press in.

2) Install "O" ring and Teflon ring to piston seal. Install seal ring in pinion housing with handle and drift (1801 and 5184). Seal ring lip must face up.

3) Make sure bearing turns freely on pinion shaft. Install to pinion housing with handle and drift. Fit spacer washer from the rack toothed side. Cover rack teeth with tape and lubricate with automatic transmission fluid.

4) Install seal with lips facing inward. Install tapered spacer washer with taper facing seal ring. Install second spacer washer. Remove tape and push 2 spacer washers together.

5) Fill rack teeth with lubricant (Volvo P/N 116 001-1). With teeth facing up, insert rack into tube. As seal ring enters tube, apply pressure on rack.

6) Seal ring and distance washers will lock into position in tube. Looking through inner high pressure hole, line up Teflon ring with center of hole.

7) Pull rack rod back until it is positioned flush with pinion housing left side. DO NOT pull rack further back. Cover threads and edge of rack with tape.

8) Install rack sleeve with seal facing to the right. Take care not to damage sleeve outer "O" ring against lock wire groove. Install plastic spacer in rack with bevelled edge toward seal.

9) Remove tape. Place sleeve on rack with tool recess facing steering rod end. Turn sleeve to line up hole in lock sleeve with elongated hole in tube.

10) Using a new lock wire, install wire in lock wire groove. Slowly turn sleeve counterclockwise until end of locking wire is positioned inside elongated hole in tube.

11) If removed, install inner race for pinion lower bearing. Pack pinion gear with lubricant. Install rack rod in housing.

12) With pinion in place, rack should protrude 2 1/8" (55 mm) from housing when flat of lock bolt is in positions shown. See Fig. 4.

Fig. 4: Positioning Rack Rod Pinion

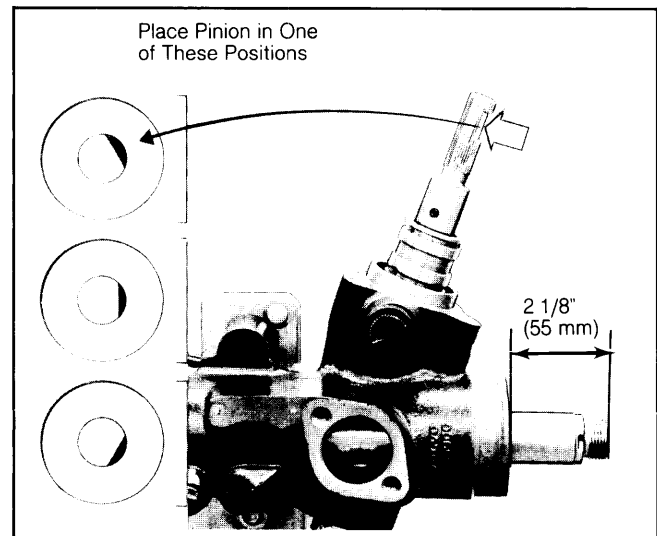

Pinion gear should be filled with grease.

NOTE: Be careful when installing pinion not to damage valve.

13) Use pinion bearing sleeve (5049) to screw on inner bearing. Shaft end should protrude 23/64" (9 mm). Install outer race for lower pinion bearing.

14) Install spacer sleeve on top of bearing race. Screw in sleeve until it bottoms. Place lock washer in position on housing and finger tighten bolts.

15) Bend down lock washer tab which is lined up with one of the recesses on sleeve. Remove bolts and washer. Install "O" ring in lower part of valve housing.

16) Install valve housing, being careful not to damage housing or pinion valve. Install coil spring with large end down. Using cover installing sleeve (5182) place "O" ring in position.

17) As cover is installed, make sure that coil spring is not squeezed under cover. Install dust seal. Install lock washer and nut. Use pinion shaft socket (5179) to hold pinion when tightening nut. Do not lock with washer tab.

18) Measure preload piston clearance. Place piston without "O" ring in housing. Measure clearance between piston and housing. Use a feeler gauge and ruler.

19) Press piston against rack, while sliding rack back and forth. Note maximum clearance. Select shim with thickness .002-.006" (.05-.15 mm) greater than thickness noted in step 18).

20) Place spring in position. Install shims and gasket, with gasket closest to aluminum housing. Install

Power Steering

VOLVO POWER-ASSISTED RACK & PINION (Cont.)

cover and tighten. Measure pinion torque with pinion shaft socket and torque gauge (9177).

21) Crank rack back and forth between rack end positions. Correct torque should be .7-1.3 ft. lbs. (.9-1.7 N.m). If torque in any position is excessive, stop rack in that position and readjust preload.

22) If rack binds with preload removed, rack is warped and must be replaced. Use a spanner on ball joint and support rack end with a large adjustable wrench to install steering rods.

23) Lock steering rods in rack recess using a narrow punch. Remove steering gear from holding fixture. Fill rubber boots with approximately 3/4 ounce of lubricant.

24) Install boots and equalizer tubes at the same time. Install plastic clamps on boots. Secure equalizer tube with strip clamp. Install 2 high pressure lines.

Disassembly (ZF Type)

1) Clean exterior of gear. Cut plastic clamps and remove equalizer tube. Attach steering gear to holding fixture (5046). Install gear and fixture to repair stand (5154).

2) Disconnect rubber boots and remove grease. Check inner and outer ball joints for wear. Unfold lock washer tab. Using a 1 1/16" (27 mm) spanner on ball joint and large adjustable wrench on rack. Remove steering rods.

3) Remove pressure lines and drain fluid. Turn rack in and out with pinion socket (5179) to pump out fluid. Remove preload piston by removing cover, washer, spring and piston. Remove rubber dust cover from pinion shaft.

4) Remove pinion housing cover with seal and "O" ring. Lift out pinion with upper roller bearing. Remove lower washer and needle bearing. Index mark position of center tube on housing. Do not use a punch to mark center tube.

5) Remove "O" ring from center tube. Only remove lock ring, if lock collar is damaged and needs to be replaced. Check rubber seal, replace if necessary.

6) Withdraw bearing from outer (right) tube end. First remove Teflon bushing with a screwdriver. Tap out seal with a 1 1/16" (27 mm) socket and a short extension.

7) Using seal extractor under washer, remove Teflon bushing, seal, and washer from right housing. Remove seal and "O" ring from top cover.

8) Remove depressor and "O" ring from preload piston. Remove Teflon seal rings from pinion valve assembly.

Inspection

Clean all parts and inspect for wear or damage. Replace as necessary.

Reassembly

1) If removed, lubricate needle bearing with lubricant (Volvo P/N 1 161 001-1). Install to pinion housing with drift. Bearing bottom should be flush with housing.

2) Install bearing race (bevelled edge down), needle bearing and bearing race to pinion housing. Do not use lubricant at this time. See Fig. 5.

NOTE: Before installing any seals, preload of pinion bearing must be checked.

3) Install pinion assembly without seals. Install bearing, race and spacer washer to pinion. See Fig. 5.

Fig. 5: Installing Pinion Bearings and Races

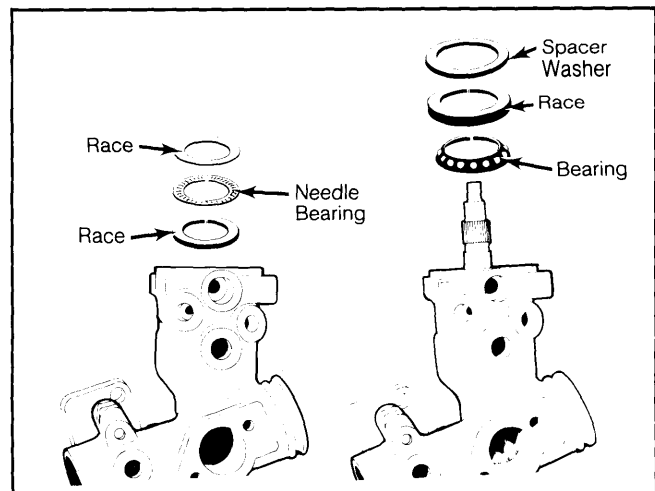

Race is installed with beveled edge down.

Install pinion housing cover. Tighten cover bolts to 7 ft. lbs. (10 N.m).

4) To adjust pinion, tie a string around shaft. Attach a spring gauge and measure turning force. Force should be 3.7-6.4 lbs. (1.7-2.9 kg). Adjust by replacement of spacer washer. See Fig. 5.

5) Washers are available in increments of .0004" (.01 mm) from .075" (1.91 mm) to .10" (2.45 mm). Remove pinion with bearings and spacers.

6) Install 4 rubber "O" rings in valve body grooves. Install 4 Teflon rings over "O" rings.

NOTE: Green Teflon ring must be installed as indicated by arrow in Fig. 6.

7) Install pinion housing seal in housing with lips up. Fill lubricant in space between seal lips. Use drift (5184) and handle (1801) to install.

8) Install spacer ring to housing with cone end in, grooved end out. Install bronze bushing in spacer (inner) tube with chamfered side down.

Fig. 6: Installing Green Teflon Ring to Pinion

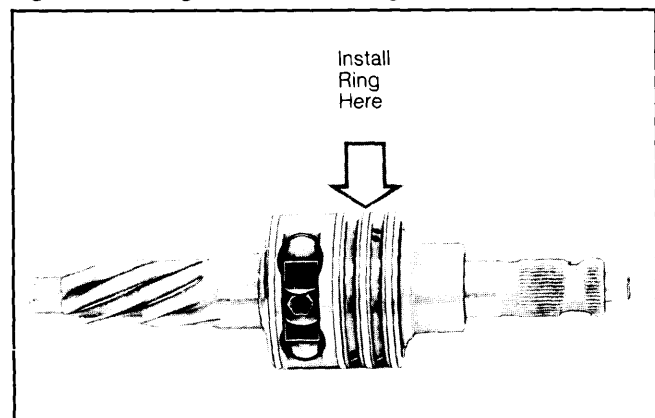

Ring must be installed at arrow

9) Fill lubricant in space between seal lips and install seal in spacer tube with lips up. Use drift and handle. If removed, install replacement spacer washer and lock ring to tube (only if removed).

VOLVO POWER-ASSISTED RACK & PINION (Cont.)

10) Install lock ring with notch (for wrench) facing center of tube. Smear threads and lock ring with lubricant. Install "O" ring. Lubricate Teflon bushing with ATF and install. Install spacer.

11) Grease seal lip and install with lip facing up. Use drift (5184) and adapter (5269) with extension pieces and install. Install Teflon ring and "O" ring to tube. Fill snap ring grooves and coat surrounding area with wheel bearing grease.

12) Slide tube into steering rack from smooth end and pass quickly over snap ring. Install "O" ring and piston ring to piston. Collar threads should be lubricated before installation.

13) Adjust steering rack so it protrudes 2 1/16" (53 mm) from edge of housing. Fill pinion teeth with lubricant. Install bearing washer with bevelled edge down.

14) Attach thrust washer and thrust bearing to valve body with grease. See Fig. 5. Hold pinion with flat surface in line with upper high pressure outlet and insert to housing.

15) As the pinion enters housing, it will turn. When fully seated, the flat surface should be parallel to flat surface of housing. Rack must not have moved. Install bearing, race and spacer washer of predetermined thickness. See Fig. 5.

16) Fill top cover seal lips with lubricant. Install seal on drift (2863) with seal lips toward tool. Remove screw and cone. Tap seal in cover. Oil "O" ring with automatic transmission fluid and install.

17) Install cover on sleeve (5182), with cone attached. Remove cone. Install cover. Tighten bolts. Install dust seal. Insert preload piston without "O" ring.

18) Be sure Teflon insert is on piston. Set up preload measuring fixture (5865) using cover bolt hole and a 8 x45 mm bolt. Assemble tool with the preload spring between bolt head and bolt. Adjust for slight preload.

19) Move gear lock-to-lock and make sure it does not jam. With micrometer measure distance between housing face and piston stop. Check measurement at 3 different points on steering rack. Subtract .004-.006" (0.1-.15 mm) from smallest reading obtained. Select washer of that thickness.

20) Washers are available in thickness of .083-.114" (2.1-2.90 mm) in increments of .0019" (.05 mm). Remove press tool (5865). Lubricate "O" ring and install on preload piston. Install spacer washer and piston spring.

21) Fill space around spring with lubricant. Apply sealant on cover sealing surface. Install and tighten cover. Install and tighten pressure lines. Make sure "O" rings seat correctly. Using spanner and adjustable wrench.

22) Install steering rods. Bend back steering rod locks. Install boots. Fill each boot with approximately 3/4 ounce of lubricant. Install boot clamps. Install equalizer tube and plastic clamps.

TIGHTENING SPECIFICATIONS

Application	Ft. Lbs. (N.m)
Pinion Cover	
Cam Gear	14 (19)
ZF	7 (10)
Preload Device Cover	
Cam Gear	13 (18)
ZF	15 (20)
Line Fitting (ZF)	14 (20)
Valve Housing Cover	14 (19)