

Steering Gears & Linkage

ISUZU & LUV RECIRCULATING BALL

Isuzu & LUV Pickups

DESCRIPTION

STEERING GEAR

Steering gear is a recirculating ball and nut type. A worm gear is incorporated on lower end of steering shaft and is engaged with ball nut through a number of recirculating balls.

Adjustment is provided for backlash between sector gear and ball nut by a tapered sector gear in steering unit. Adjustment screw is on sector shaft.

Fig. 1: Exploded View of Recirculating Ball Steering Gear Assembly

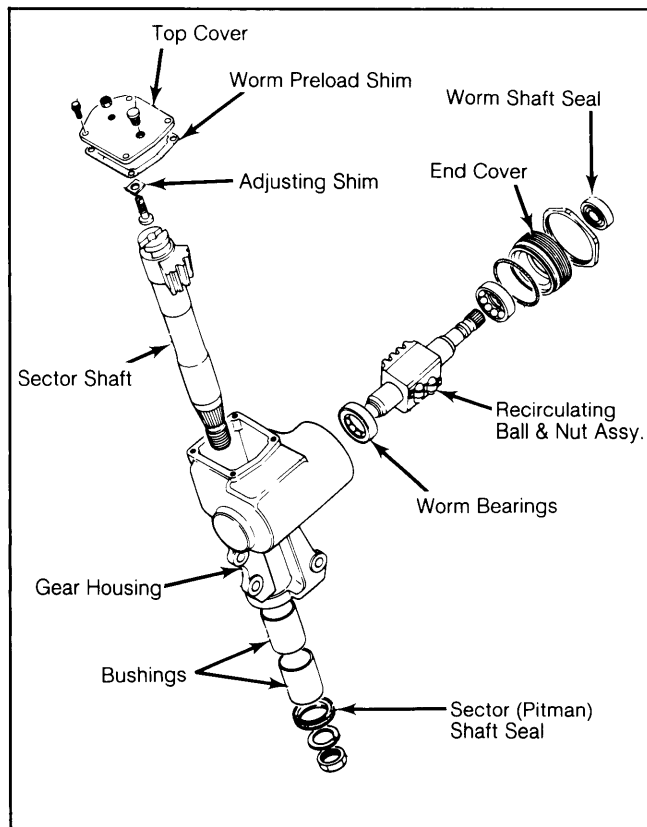

STEERING LINKAGE

1) Linkage consists of splined pitman arm connected to an adjustable center link on 2-WD models or non-adjustable center link on 4-WD models.

2) Center link is attached to an idler arm and then to tie rods. Idler arm is attached to frame by a bracket. Tie rods are non-adjustable on 2-WD models. Tie rods are adjustable on 4-WD models.

ADJUSTMENT

PRELOAD & LASH

1) Disconnect battery ground cable, then raise and support front of vehicle. Remove pitman arm nut and mark position of arm-to-shaft. Remove arm using puller. Remove horn shroud and spring.

CAUTION: Do not turn wheel hard against stops, as damage to ball guides may result.

2) Turn steering wheel in one direction until stopped by gear, then turn back half way. Measure and record "bearing drag" by attaching torque wrench to steering wheel nut and rotating through a 90° arc.

NOTE: Do not use a torque wrench having a maximum reading of more than 50 INCH lbs. (6 N.m).

3) Adjust sector lash by turning steering wheel from one stop to the other. Turn wheel back exactly halfway to obtain center position. Turn sector adjusting screw clockwise to eliminate backlash between ball-nut and sector gear. Tighten lock nut.

Fig. 2: Adjusting Sector Gear Lash

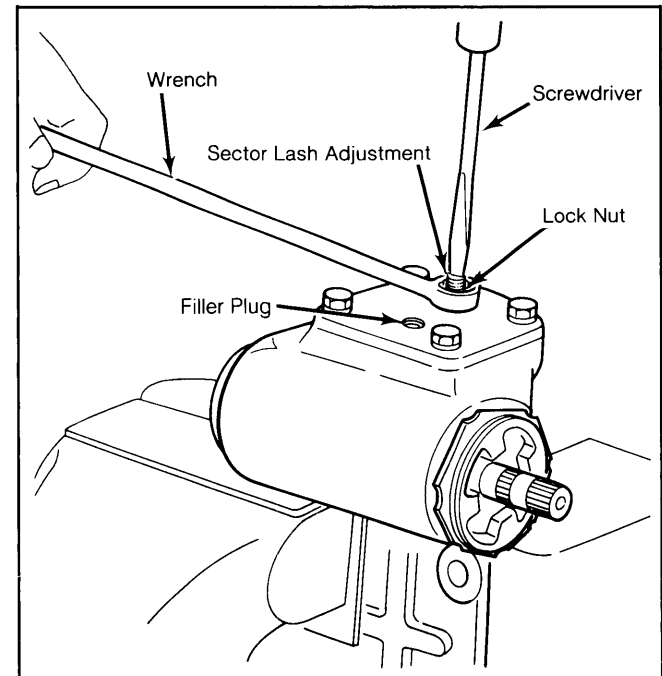

Turn adjusting screw clockwise to remove cover.

4) Check torque at steering wheel nut, taking highest reading as steering wheel turns through center. Torque should be 4.3-8.7 INCH lbs. (.5-1.0 N.m). If not, loosen lock nut and readjust sector screw. Tighten lock nut and recheck torque at steering wheel.

5) If maximum specification is exceeded, turn adjusting screw counterclockwise. Turn adjuster lock nut clockwise. Reassembly pitman arm to shaft, lining up marks made during removal. Tighten pitman shaft nut to specifications. Install horn spring and shroud. Connect battery cable.

REMOVAL & INSTALLATION

STEERING LINKAGE

Removal

1) Raise and support vehicle. Disconnect tie rod ball joints from steering knuckle. Remove pitman arm-to-sector shaft nut and lock washer. Mark relative position

ISUZU & LUV RECIRCULATING BALL (Cont.)

Fig. 3: Exploded View of Steering Linkage

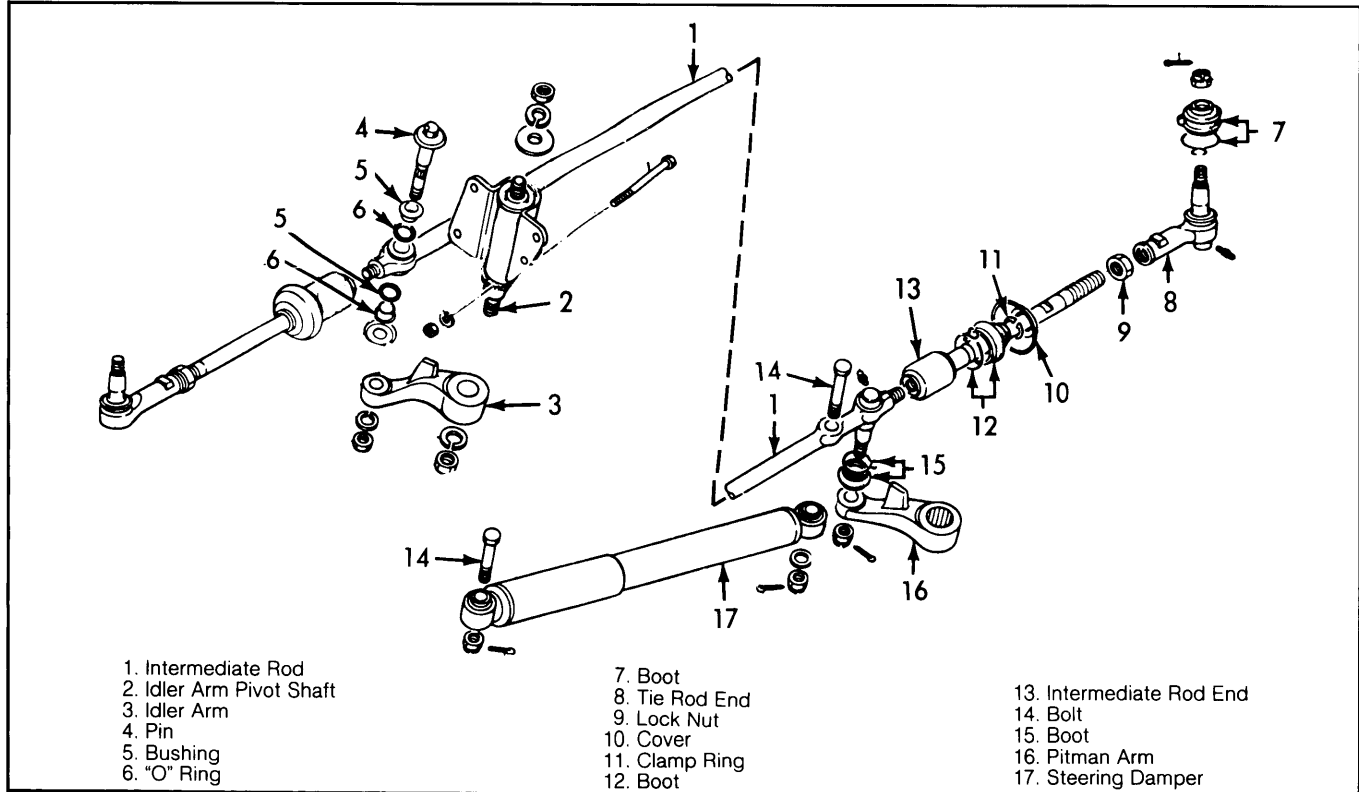

2-WD model is shown.

of pitman arm-to-sector shaft and remove pitman arm from sector shaft.

2) Remove idler arm-to-pivot shaft nut and lock washer. Remove idler arm from pivot shaft. Linkage can now be removed from vehicle. If necessary to remove pivot shaft and bracket, unscrew pivot arm from bracket and remove pivot arm. Remove bolts securing bracket from frame and remove bracket.

Installation

To install steering linkage, reverse removal procedures and note the following. When installing idler arm to pivot shaft, make sure distance from bottom of pivot shaft bracket to bottom of idler arm is 1.280-1.366" (32.5-34.7 mm) after tightening pivot shaft nut. Also make sure marks made on pitman arm and sector shaft are aligned during installation.

STEERING GEAR

Removal

1) Raise and support vehicle. Remove pitman arm nut and mark relative position of pitman arm-to-shaft. Using a puller, remove arm from shaft.

2) Remove engine protection shield. Remove lower clamp-to-flexible coupling bolts. Remove steering gear-to-frame bolts and remove steering gear.

Installation

1) Place gear in position and start (do not torque) gear mounting bolts. Install clamp-to-coupling bolts and torque.

2) Tighten gear mounting bolts. Install pitman arm, aligning index marks and tighten nut. Install engine protection shield.

OVERHAUL

STEERING GEAR

NOTE: Recirculating ball and nut assembly parts are selectively combined. Ball tube clamp plate is sealed with paint to prevent disassembly. Any worn part, therefore, necessitates entire assembly replacement.

Disassembly

1) Remove steering gear as previously described. Disconnect flexible coupling from worm shaft. Drain gear box through filler plug hole. Place sector shaft in straight ahead (center) position.

NOTE: Mark location of coupling on worm shaft before removal.

2) Remove top cover bolts and adjusting screw lock nut. Separate top cover from gear box by turning adjusting screw clockwise. Hold sector shaft in straight-ahead position during removal and DO NOT drive shaft off gear box by impact.

3) Remove adjusting screw and sector shaft from gear case. Remove end cover bolts and shims. Pull worm gear and ball nut assembly from gear box and take out lower bearing.

CAUTION: Keep assembly in horizontal position or ball nut will fall onto end of worm gear, damaging ball tubes.

Steering Gears & Linkage

ISUZU & LUV RECIRCULATING BALL (Cont.)

Inspection

1) Wash all parts in clean solvent. Check steering shaft for bending. Check ball-nut teeth for dents and wear. Check bearings for wear or damage.

2) Check threaded portion of ball-screw for dents or damage. Check ball-nut for smooth operation on worm shaft.

CAUTION: Do not let ball-nut bottom out on worm shaft by its own momentum.

3) Hold worm and ball-nut assembly in vertical position, allowing ball-nut to travel downward on worm shaft. Check sector shaft and shaft teeth for wear or damage.

Reassembly & Adjustment

1) Insert lower bearing into position in gear box. Install worm shaft assembly in box. Check lower end of worm shaft for proper fit in lower bearing.

2) Assemble upper bearing onto worm shaft and install adjusting shims between gear housing and end cover. Install and tighten bolts.

NOTE: Apply liquid gasket to end cover during installation.

3) At this point, measure starting torque of pinion shaft. See Fig. 4. Reading should be 2.6-5.2 lbs. (1.2-2.4 kg) when coupling begins to rotate. If not within limits, add or remove shims as necessary.

Fig. 4: Measuring Steering Gear Starting Torque

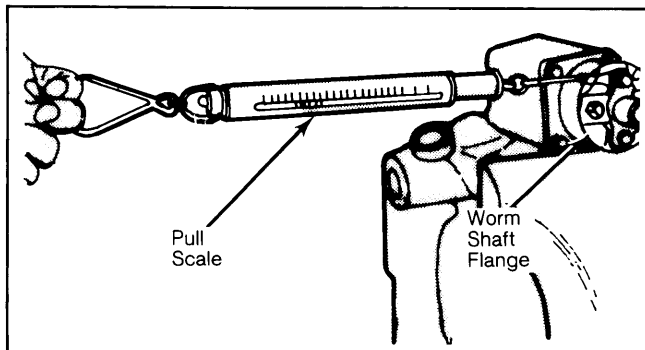

4) Bring ball nut to center of worm and insert sector shaft into gear box. Engage center tooth of shaft with center tooth of worm. Insert adjusting screw in sector shaft slot.

5) Screw should slide freely within slot and have no more than .004" (.10 mm) clearance. If clearance is excessive, insert adjusting shim. Install sector cover while turning adjusting screw out. Tighten lock nut.

6) Check total gear preload (starting torque) using pull scale as shown in Fig. 4. If reading is between 4.3-10.5 lbs. (2.0-4.8 kg), no further adjustments are required.

7) If correct specification is not obtained, turn adjusting screw until preload is within specifications. Tighten lock nut.

8) Connect sector shaft to pitman arm (align marks made during removal) and tighten pitman arm nut. Install and tighten pinch bolt. Fill gear assembly with .5 pts. of lubricant. Do not overfill.

PITMAN SHAFT SEAL REPLACEMENT

NOTE: If replacement has been determined as necessary, it may be done without removing the steering gear.

1) Raise and support vehicle. Remove pitman arm as previously described. Clean area around seal. Pry out old seal, being careful not to damage housing bore.

CAUTION: Check gear lubricant for contamination. If contamination of any kind is detected, gear overhaul is necessary.

2) Coat new seal with gear lubricant and tap into position. Install pitman arm and nut. Lower vehicle and check lubricant level in gear assembly.

TIGHTENING SPECIFICATIONS

Application	Ft. Lbs. (N.m)
Ball Joint Nut	44 (60)
Center Link Lock Nut	89 (121)
Idler Arm Nut	89 (121)
Sector Lash Nut	14-21 (20-30)
Pitman Arm Nut	162 (220)

INCH Lbs. (N.m)

Sector Lash Adjustment	4.3-8.7 (.5-1.0)
Total Steering Gear Preload	4.3-10.5 (.5-1.2)
Worm Bearing Preload	2.6-5.2 (.3-.6)