

Steering Gears & Linkage

DATSUN/NISSAN RECIRCULATING BALL

200SX, 210 & Pickup

DESCRIPTION

The steering gear used on these vehicles is a recirculating ball type. The worm shaft is joined to the steering shaft by a rubber shock-absorbing coupling.

The steering linkage is a relay design, with the steering gear attached by a pitman arm to one end of the center link (cross shaft), while the other end of the center link moves on the idler arm.

REMOVAL & INSTALLATION

STEERING GEAR

Removal

1) On 210 models, remove clutch operating cylinder (if equipped). Do not remove clutch hose. Disconnect exhaust pipe from manifold. Disconnect any brackets holding exhaust pipe in place.

2) On all models, remove bolt holding worm shaft to rubber coupling. Remove nut holding gear arm to sector shaft and remove steering gear arm from sector shaft.

3) Remove bolts securing steering gear housing to body side member. Remove steering gear housing from vehicle.

Installation

To install, reverse removal procedure, aligning markings on pitman arm with markings on sector shaft.

Fig. 1: Datsun Steering Gear Linkage (210 Shown, Others Similar)

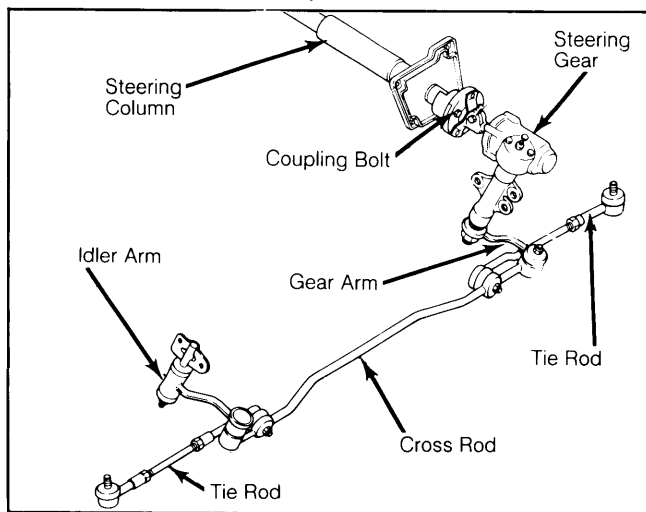

STEERING LINKAGE

Removal

1) Jack up front of vehicle and support with stands. Detach both outer tie rod ends from steering knuckles.

2) Separate cross shaft from idler arm and pitman arm, then remove cross shaft and tie rods as an assembly. Idler assembly may be removed from side member, if necessary to replace bushing.

Installation

To install, reverse removal procedure, noting the following: Set tie rod end length to the prescribed

setting, then check wheel alignment. See Datsun in *WHEEL ALIGNMENT* section.

TIE ROD SETTINGS

Application	In. (mm)
200SX ¹	2.80 (71.0)
210 ²	12.40 (315.0)
Pickup ²	
2WD	13.07 (332.0)
4WD	10.83 (275.0)

¹ — Measured between lock nuts.

² — Measured from center-to-center of tie rod ball studs.

ADJUSTMENT

NOTE: Steering gear adjustments are performed during reassembly. See Overhaul as outlined below.

OVERHAUL

DISASSEMBLY

Steering Gear

1) Drain gear box of oil, then place unit in padded vise or on holding fixture mounted in a vise.

2) On 210 models, loosen adjusting screw lock nut and remove sector shaft cover screws. Turn adjusting screw a few turns clockwise and withdraw sector shaft. Remove rear cover. Withdraw bearing shims and worm assembly. Remove oil seal if necessary.

3) On 200SX and Pickup models, place worn gear in straight ahead position and remove sector shaft cover with sector shaft. Separate cover from sector shaft and remove oil seal if necessary. Remove adjusting plug lock nut and adjusting plug. Withdraw worm assembly out of gear box. Remove oil seal from adjusting plug.

NOTE: Do not remove sector shaft bearings or bushings from housing. If defective, replace housing assembly. Do not disassemble ball nut; replace, if necessary, with worm shaft assembly. Do not let ball nut bottom out on either end of worm shaft, or damage to ball guides will result.

INSPECTION

Inspect gear teeth on sector shaft and ball nut for wear or damage; replace as necessary. Check bearings for wear or roughness during rotation. Ensure ball nut moves smoothly over its entire length of travel.

REASSEMBLY & ADJUSTMENT

Steering Gear

1) On 210 models, lubricate bearings, gear and all moving parts with gear oil. Apply grease to oil seal lip and press seal into rear cover. Install worm assembly, with bearings, into housing. Install shims (thicker shim to housing side) and rear cover.

DATSUN/NISSAN RECIRCULATING BALL (Cont.)

NOTE: Standard shim thickness for 210 models is .059" (1.5 mm) for large housing models and .020" (.5 mm) for small housing models. See Worm Bearing Shim Chart for available sizes.

Fig. 2: Exploded View of Recirculating Ball Steering Gear Assembly (200SX & Pickup Models)

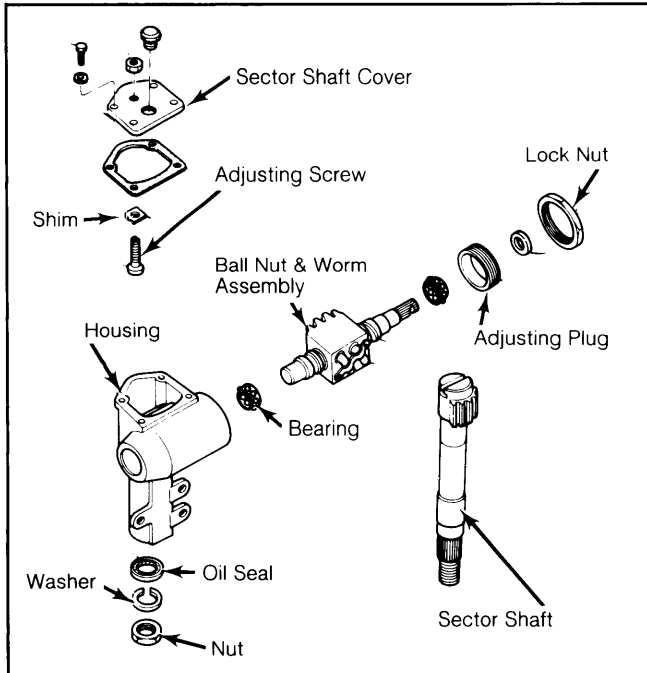
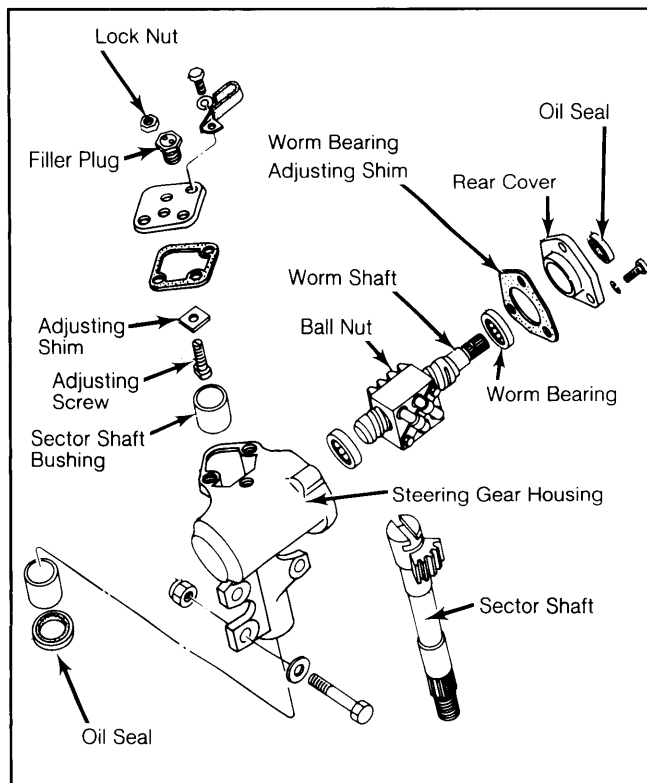

Fig. 3: Exploded View of Recirculating Ball Steering Gear Assembly (210 Model)



WORM BEARING SHIMS

Shim No.	In. (mm)
210 (Large Housing)	
1	.030 (.762)
2	.010 (.254)
3	.005 (.127)
4	.002 (.050)
210 (Small Housing)	
1	.0020 (.050)
2	.0027 (.070)
3	.0031 (.080)
4	.0040 (.100)
5	.0080 (.200)

2) On 200SX, and Pickup models, lubricate bearings, gear and all other moving parts with gear oil. Apply grease to oil seal lip and press seal into adjusting plug.

Worm Bearing Preload

1) On all models, rotate worm shaft a few times to settle assembly. Attach torque wrench to worm shaft and measure bearing preload (initial turning torque). Add or subtract shims on 210 models or tighten adjusting plug on all other models until specified preload is obtained.

WORM BEARING PRELOAD SPECIFICATIONS

Application	INCH Lbs. (N.m)
210	
Small Housing	1.7-4.3 (2-5)
Large Housing	3.5-5.2 (4-6)
All Other Models	3.5-5.2 (4-6)

Fig. 4: Measuring Steering Gear Initial Turning Torque to Check Worm Gear Preload

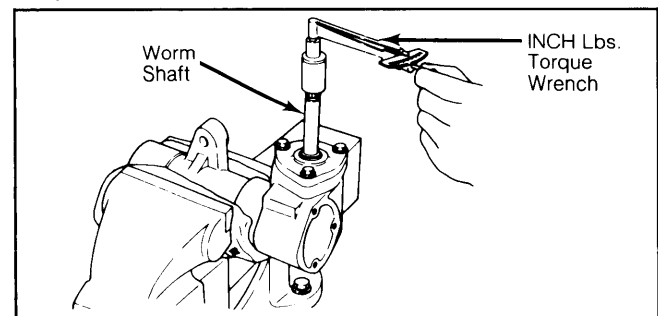

2) With preload adjusted, apply sealer to lock nut on 200SX and Pickup models, then tighten lock nut. On 210 models, remove rear cover and shims; apply sealer to shims and rear cover, then reinstall shims and rear cover.

Sector Shaft End Play

1) Insert adjusting screw into "T" groove of sector shaft and adjust end play between shaft and screw head to less than .002" (.05 mm) on 210 models with small gear housing, or to .0004-.0012" (.01-.03 mm) on all other models.

2) On 210 models, rotate worm shaft until ball nut is in center of travel. Install sector shaft and adjusting screw in gear housing. Ensure center tooth of sector shaft is engaged with center of ball nut. Apply sealer and gasket material to sector shaft attaching face.

Steering Gears & Linkage

DATSUN/NISSAN RECIRCULATING BALL (Cont.)

Fig. 5: Insert Feeler Gauge into Sector Shaft to Measure Sector Shaft-to-Adjusting Screw End Play

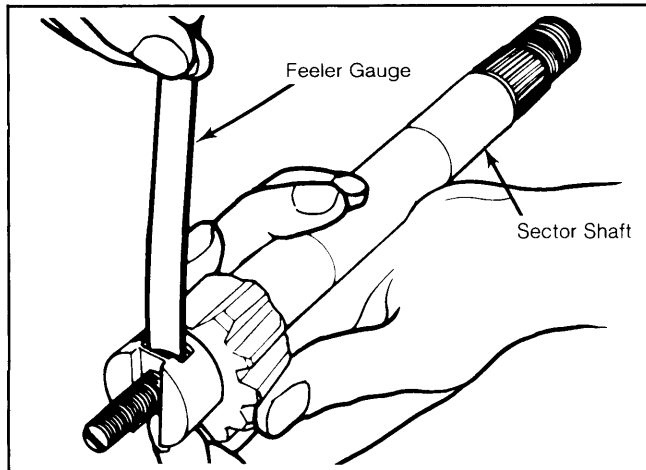

End play is decreased by installing shims.

3) Turn adjusting screw counterclockwise to set cover on gear housing. Temporarily install retaining bolts. Turn adjusting screw further counterclockwise until sector shaft is drawn upward about .08-.12" (2-3 mm). Fully tighten bolts.

4) Push sector shaft against ball nut by gradually turning adjusting screw until sector shaft gear lightly meshes with ball nut gear, and temporarily secure adjusting screw with lock nut.

Steering Gear Preload

1) Install pitman arm to sector shaft and move it side-to-side several times to ensure smooth operation. See pitman arm at center point and adjust backlash (by turning adjusting screw) such that free movement at top of pitman arm is .004" (.1 mm). Tighten lock nut and fill gear box with gear oil.

2) On 200SX and Pickup models, install cover to sector shaft (with adjusting screw). Place worm gear in center position, then install sector gear to gear housing (with gasket) and tighten bolts. Fill gear box with gear oil.

3) Install torque wrench to worm shaft. Tighten sector shaft adjusting screw while measuring total gear turning torque (preload). Total preload should be less than 10.9 INCH Lbs. (1.2 N.m).

NOTE: Always adjust preload by tightening adjusting screw, never by loosening.

TIGHTENING SPECIFICATIONS

Application	Ft. Lbs. (N.m)
Adjusting Plug Lock Nut	
200SX & Pickup	181-231 (246-314)
Ball Stud Nuts	
200SX & 210	22-51 (30-69)
Pickup	40-72 (54-98)
Gear-to-Frame	
200SX	38-46 (52-63)
210	51-58 (69-79)
Pickup	33-38 (45-52)
Pitman Arm-to-Gear	94-108 (128-147)
Tie Rod Lock Nuts	
Pickup	8-12 (11-16)
200SX & 210	58-72 (79-98)