

DATSUN/NISSAN RACK & PINION

280ZX, 310, Maxima, Sentra, Stanza

DESCRIPTION

Steering assembly is a direct-acting rack and pinion system. Unit consists of a rack bar and toothed pinion, both working in the plain bearing of the rack housing.

Backlash is held to zero by the retainer and retainer spring.

REMOVAL & INSTALLATION

Removal

1) Raise and support front of vehicle. Remove tie rod from steering knuckle. Loosen steering gear mounting bolts.

2) On 280ZX and Maxima models, loosen bolt attaching lower joint shaft to rubber coupling.

3) Remove bolts attaching steering column to lower joint. Remove steering gear and linkage assembly.

NOTE: On 280ZX models, raise front engine mount approximately 1/2" (with jack) before trying to remove steering gear.

Installation

Install in reverse order of removal procedure.

Check wheel alignment. For wheel alignment procedures, see Datsun in WHEEL ALIGNMENT section.

ADJUSTMENT

NOTE: Adjustments are performed during gear assembly process. See Overhaul as outlined.

OVERHAUL

DISASSEMBLY

Steering Gear

1) Clamp steering gear and linkage in a padded vise. Remove both dust boot clamps. Flatten lock plate. Loosen inner joint lock nut and remove tie rod from rack.

NOTE: Do not disassemble inner joint assembly and tie rod socket assembly.

2) Loosen adjuster lock nut and remove retainer adjust screw. Remove retainer spring and steering gear retainer out of steering gear housing.

3) Remove oil seal and pry off snap ring from steering gear housing. Remove steering pinion assembly and rack from steering gear housing.

Pinion Gear

1) Pry off snap ring securing pinion bearing from pinion gear. Press bearing from pinion gear, then remove inner snap ring from pinion gear.

2) On 310 models, remove steering gear rubber mount bushing by striking with rubber mallet. Remove snap ring and bushing from gear housing.

Fig. 1: Exploded View of Datsun Rack and Pinion Steering Gear Assembly

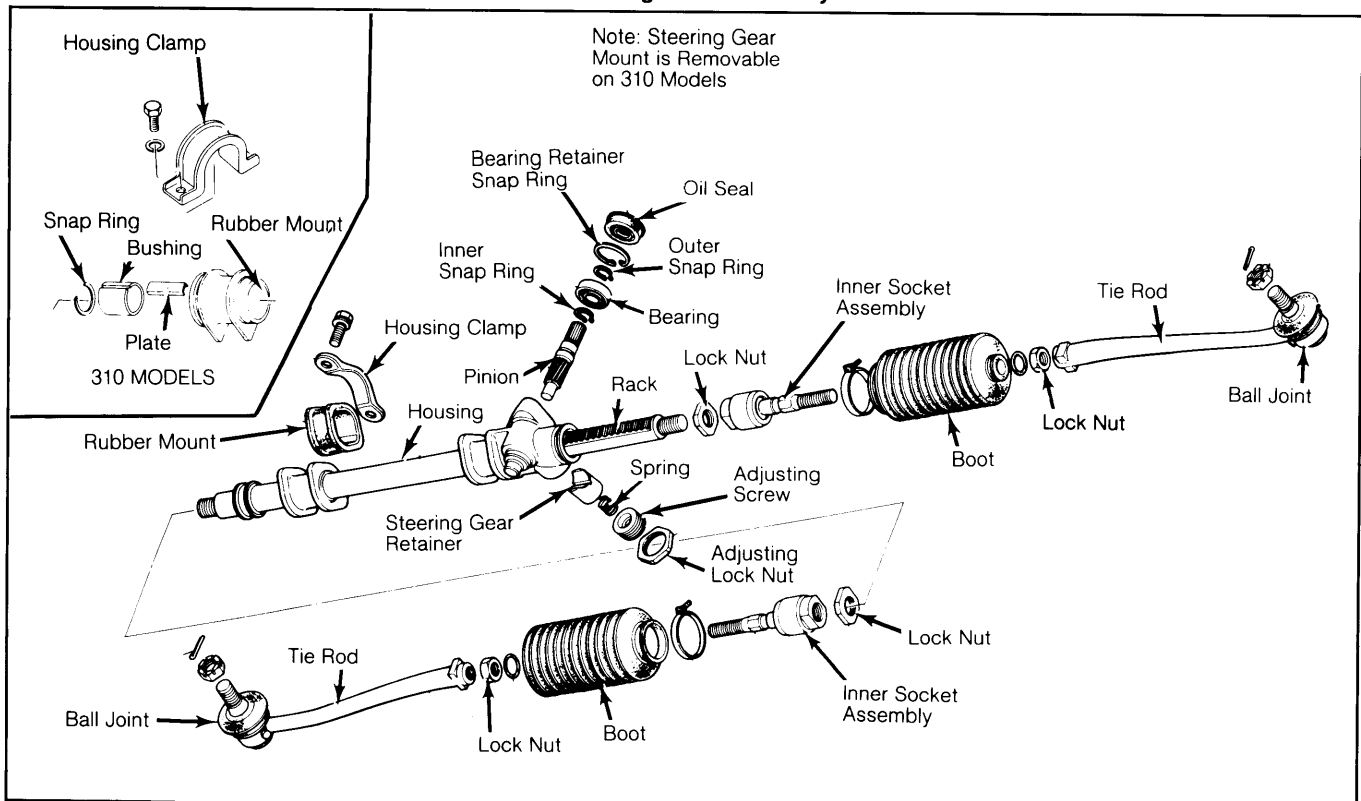

Steering Gears & Linkage

DATSUN/NISSAN RACK & PINION (Cont.)

INSPECTION

1) Check rack and pinion gear for wear or damage, replace if necessary. Inspect tie rod inner socket for smooth operation and for excessive looseness, replace if necessary. Replace all oil seals.

2) On 310 models, check rack bushing (in gear housing) for wear by measuring amount of play of rack when moved up and down then sideways.

3) Play for up and down movement should be less than .020" (.5 mm) and less than .028" (.7 mm) for sideways movement.

REASSEMBLY AND ADJUSTMENT

Pinion Gear

1) Install inner snap ring to pinion gear and then press bearing onto pinion gear. Install outer snap ring onto pinion gear.

2) Outer snap ring thickness should be selected so that bearing play is less than .004" (.1 mm).

Steering Gear Mount (310 Models)

1) Install rubber mount bushing to housing and secure with snap ring. Install rubber mount with plate onto end of housing.

2) Make sure cut out section of rubber mount is aligned with hole in housing and that ventilation hole is not clogged with grease.

Steering Gear

1) On all models, clamp steering gear in padded vise. Coat rack teeth and friction surfaces of rack with grease. Install rack into housing from pinion gear side and make sure rack teeth are facing correct direction.

2) Install pinion gear (coated with grease), make sure pinion gear teeth and rack teeth mesh properly. Make sure rack protrudes same amount from each end of housing.

3) Install snap ring to steering gear housing (snap ring retains pinion bearing in place). Snap ring thickness should be selected so that pinion gear movement is less than .004" (.1 mm). Pack grease seal with grease and install. Make sure pinion assembly rotates smoothly.

4) Apply grease to steering gear retainer and insert gear retainer and retainer spring into housing. Turn adjusting screw in and install lock nut.

5) Fully tighten adjusting screw then back off approximately 20-25°. Apply liquid sealant around lock nut and tighten lock nut.

Pinion Shaft Rotating Torque

1) With steering gear assembled, measure torque required to keep pinion and rack in motion.

2) Install steering gear in padded vise and attach torque wrench to bar and spring gauge. See Fig. 2. Torque should be as shown in Pinion Shaft Rotating Torque table.

Fig. 2: Measuring Pinion Shaft Rotating Torque

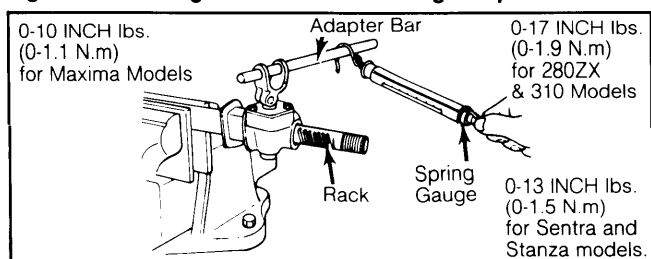

PINION SHAFT ROTATING TORQUE

Application	INCH Lbs. (N.m)
280ZX & 310	0-17 (1.9)
Maxima	0-10 (0-1.1)
Sentra & Stanza	0-13 (0-1.5)

Measuring Rack Pulling Force

1) Measure force required to pull rack from neutral (center) position. See Fig. 3. Force should be as shown in Rack Pulling Force table.

RACK PULLING FORCE

Application	Lbs. (kg)
280ZX & 310	0-22 (0-10)
Maxima	0-29 (0-13)
Sentra	22-31 (10-14)
Stanza	13-29 (5.8-13.1)

Fig. 3: Measuring Steering Gear Rack Pulling Force

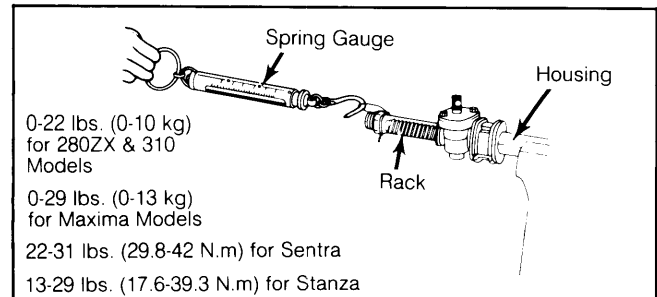

2) Install rubber boot and clamp onto tie rod. Thread lock nut over threaded portion of rack. Apply grease to sliding surfaces of tie rod inner socket and spring seat.

3) Install tie rod assembly to rack end, together with inner spring and spring seat. Screw inner socket portion until ball seat reaches rack end and then tighten lock nut.

NOTE: On 280ZX models, tie rod for left side is marked with an "L". No mark is used for right side tie rod.

Measuring Ball Joint Swinging Torque and Axial Play

Upon completion of tie rod assembly, measure swinging torque and axial play of tie rod inner socket. Swinging torque (measured at outer end of tie rod) should be as shown in Ball Joint Swinging Torque table. No axial play should exist.

BALL JOINT SWINGING TORQUE

Application	INCH Lbs. (N.m)
280ZX	0-43 (0-4.7)
310	13-61 (1.4-6.7)
Maxima	.9-69.4 (.10-7.8)
Sentra & Stanza	4.3-65.1 (.48-7.3)

Measuring Steering Gear Rack Stroke

1) Measure rack protrusion on both sides of housing. See Fig. 4. Measurement should be as shown in Steering Gear Rack Protrusion table.

Steering Gears & Linkage

DATSUN/NISSAN RACK & PINION (Cont.)

STEERING GEAR RACK PROTRUSION

Application	In. (mm)
280ZX	2.614 (66.4)
310	2.68 (68)
Maxima	2.99 (76)
Stanza	2.795 (71)
Sentra	2.894 (73.5)

Fig. 4: Measuring Steering Gear Rack Stroke

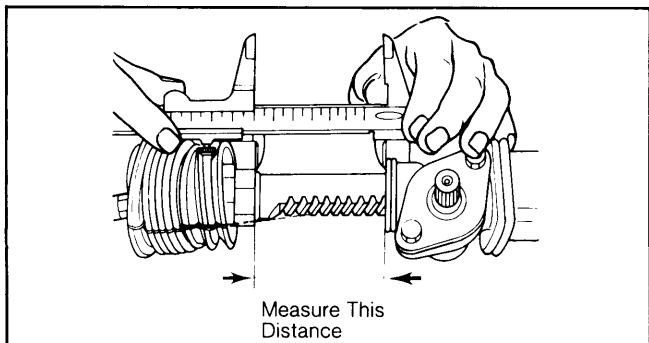

2) Attach boot and clamps. Insert grease nipples at both ends of housing and lubricate gear assembly until a small amount of grease appears at boot outlet hole.

Tie Rod Length

Adjust tie rod length so that distance from outer side of lock nut to end of boot mounting groove is as shown in Tie Rod Length table. See Fig. 5.

TIE ROD LENGTH

Application	In. (mm)
280ZX	1.161 (29.5)
310	5.24 (133)
Maxima	1.421 (36)
Sentra	6.93 (176)
Stanza	1.68 (42.6)

Fig. 5: Adjusting Steering Gear Tie Rod Length

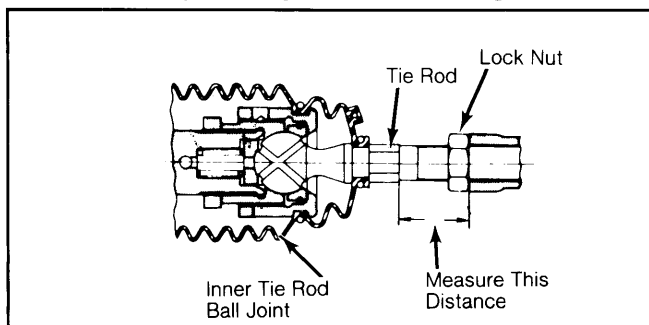

TIGHTENING SPECIFICATIONS

Application	Ft. Lbs. (N.m)
Inner Socket Lock Nut	58-72 (79-98)
Tie Rod Ball Joint Nut	40-47 (54-64)
Tie Rod-to-Socket Lock Nut	
280ZX & Maxima	58-72 (79-98)
310	27-34 (36-46)