

Steering Columns

SUBARU 1600 & 1800

DESCRIPTION

Steering column assembly consists of a steering wheel incorporating a horn control, a combination turn signal, hazard warning, and headlight dimmer switch assembly, and an energy absorbing steering shaft.

The steering column is connected to the steering gear through a universal joint coupling. The energy absorbing steering shaft is designed to collapse during a front end collision. An anti-theft locking mechanism is used to prevent steering shaft from turning when key is removed.

Fig. 1: Subaru Steering Column Assembly

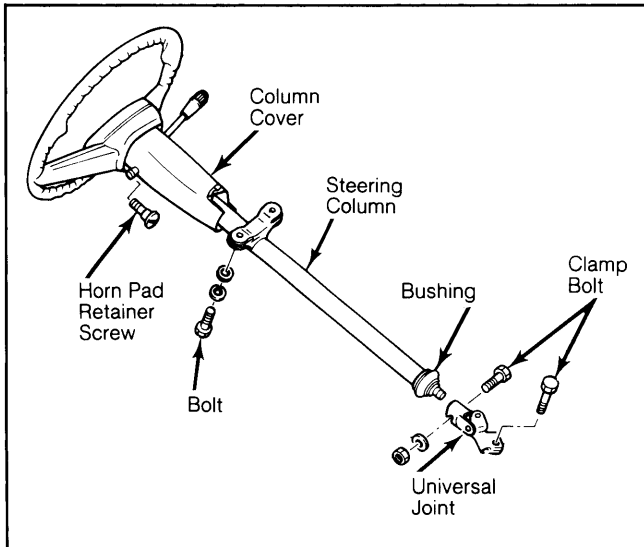

REMOVAL & INSTALLATION

STEERING COLUMN

Removal

1) Disconnect battery ground cable. Loosen the universal joint clamp bolt and separate shaft from joint.

2) Remove trim panel and unplug all wiring connectors to steering column switches. Remove steering shaft bolt from instrument panel and pull steering column from floorboard.

Installation

Insert column through floorboard into universal joint. Install column bolt into dashboard and tighten. Connect all electrical connections. Tighten universal joint bolt.

OVERHAUL

STEERING COLUMN

Disassembly

1) Clamp steering column carefully in a vise. On 2 spoke steering wheels, remove single screw retaining horn pad. On 4 spoke steering wheels, remove horn pad retaining screws from back of wheel.

2) On all models, remove horn pad. Remove steering wheel nut. Remove steering wheel. Remove column covers, combination switch and horn brush.

3) Remove screws retaining bearing to steering column. Pull out shaft from the bottom of cover. Remove snap ring, washer, "O" ring and bearing.

Inspection

1) Universal joint should have no play in any direction. Replace if any play exists. Flex universal joint and check for binding. Replace if torque required to flex joint exceeds 0.43 ft. lbs. (.58 N.m).

Fig. 2: View of Steering Shaft Lower Components

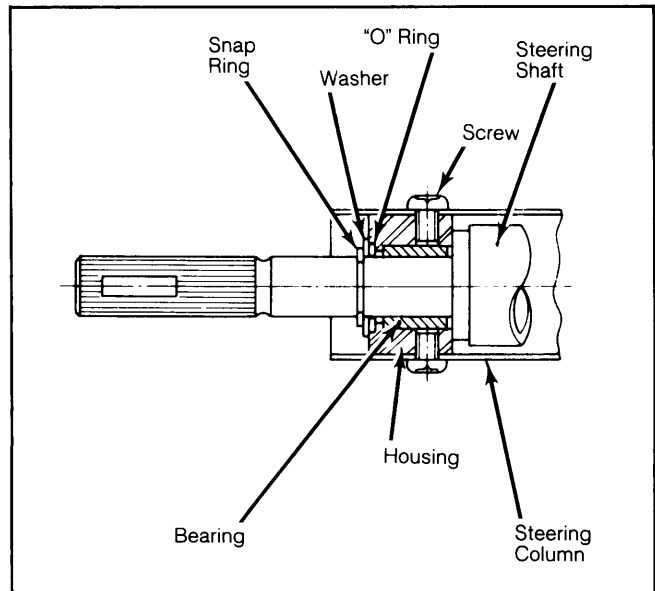

2) Check plastic washer for damage, and serration for wear. Check steering shaft for runout and length. Length should be 33.78" (857.9 mm). Runout for elliptical part of shaft should be less than 1.28" (32.6 mm).

3) Runout for collar part of shaft should be less than .024" (.6 mm). Runout for upper end of shaft should be less than .047" (1.2 mm). Replace steering shaft if not to specifications. Check bearings for wear or damage, replace if necessary.

Reassembly

To reassemble, reverse disassembly procedures. With steering wheel in place, check clearance between wheel and cover. If clearance exceeds .04-.12" (1.0-3.0 mm), loosen column cover screws and adjust cover.

TIGHTENING SPECIFICATIONS

| Application | Ft. Lbs. (N.m) |
|----------------------------|----------------|
| Column Bracket Bolt | 14-23 (19-31) |
| Steering Wheel Nut | 22-29 (30-39) |
| Universal Joint Bolt | 16-19 (22-26) |