

CHRYSLER CORP. IMPORTS RWD MODELS

Arrow Pickup, Challenger,
Ram-50 Pickup, Sapporo

DESCRIPTION

Collapsible steering column is comprised of a 2-piece column shaft, joined by a collapsible section. This section contracts under impact without affecting turning motion. The upper column cover incorporates slits that allow it to collapse under impact.

REMOVAL & INSTALLATION

STEERING COLUMN

NOTE: During any service operations of collapsible columns or components, avoid jarring or leaning on any portion of column.

Removal

1) Remove air cleaner and unbolt clamp connecting shaft to gear box. If vehicle is equipped with air conditioning, perform this step from underneath vehicle.

2) Remove horn pad, steering wheel nut, and pull steering wheel off. Loosen tilt lock lever or knob and lower wheel. Remove column cover and floor dust cover.

3) Unplug column switch connections and pull out switch. Remove tilt bracket bolts. Remove column as an assembly. Cut slot in head of bolt of wheel lock bracket. Remove wheel lock bracket and tilt bracket.

Installation

1) Connect shaft to steering gear housing mainshaft with bolt hole facing downward. Tighten the clamp bolt. Install tilt bracket to pedal support member.

2) Connect gear housing mainshaft with hole down and gear housing mainshaft in neutral position. Tighten tilt bracket-to-body.

3) Apply sealer to bolt holes of dust cover. Install dust cover to body. Install retaining bolts and tighten. To complete installation, reverse removal procedure.

OVERHAUL

STEERING COLUMN

Disassembly

1) Remove snap ring. Remove steering shaft together with dust seal and bushing from column tube. Remove yoke and coupling from lower end of steering shaft.

2) Remove snap ring. Using a soft mallet, lightly tap upper end of steering shaft. Remove shaft from column tube.

Fig. 1: Exploded View of Challenger & Sapporo Steering Column Components

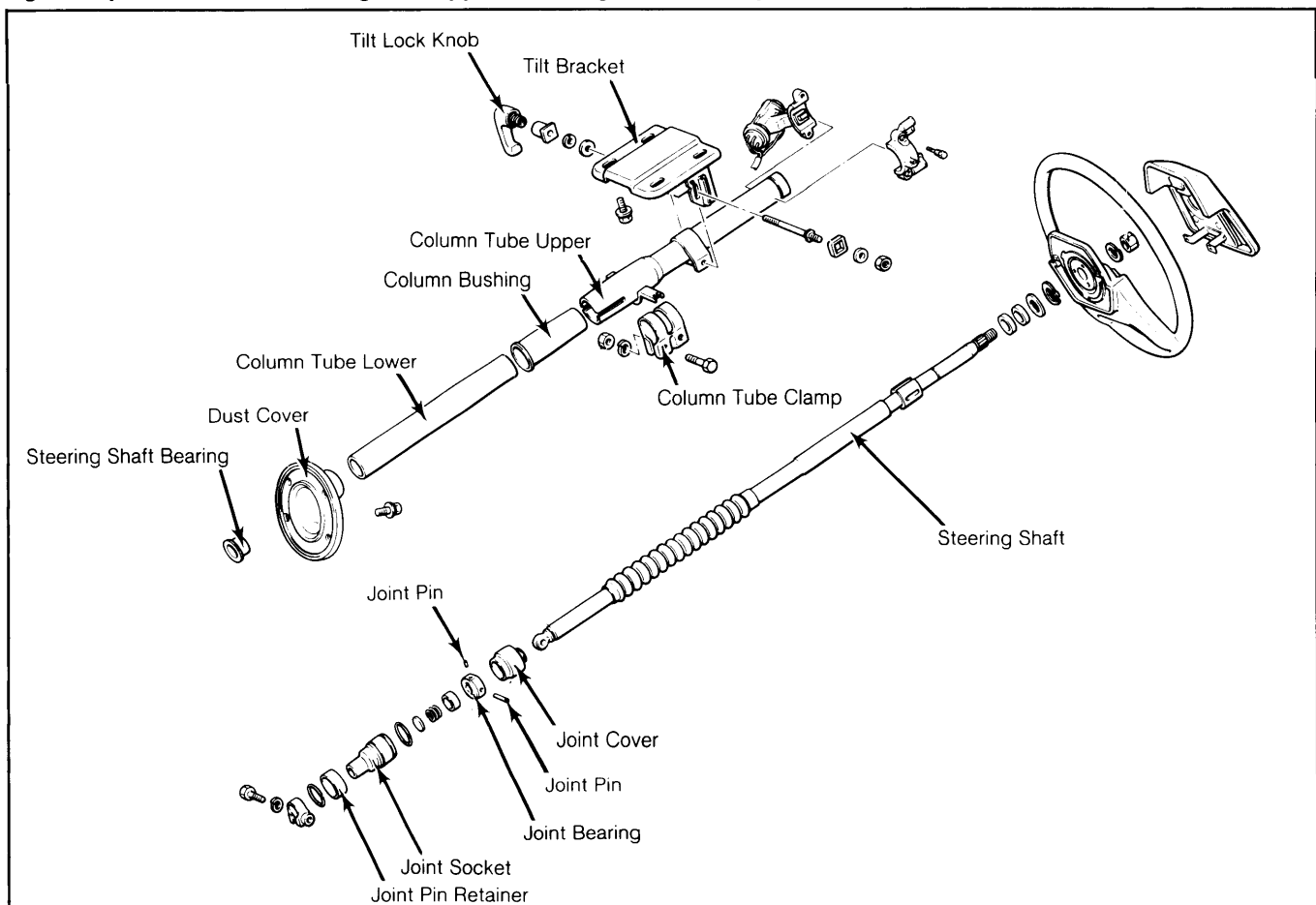

Steering Columns

CHRYSLER CORP. IMPORTS RWD MODELS (Cont.)

3) Slide dust cover off joint socket toward steering shaft side. Remove the stopper. Remove joint retainer. Set steering shaft in upright position.

4) Press down on shaft and remove small retaining pin with a magnet. Do not drive pin out. Remove joint socket.

5) Remove big joint retaining pin only if necessary, using a hand press. Loosen column tube clamp. Draw out lower column tube and remove column bushing.

6) When removing tilt bracket, cut a slot in head of retaining studs. Unscrew studs and remove steering lock. Lightly tap tilt bracket with a soft mallet to drive bracket assembly from upper end of column tube.

Fig. 2: Exploded View of Steering Column

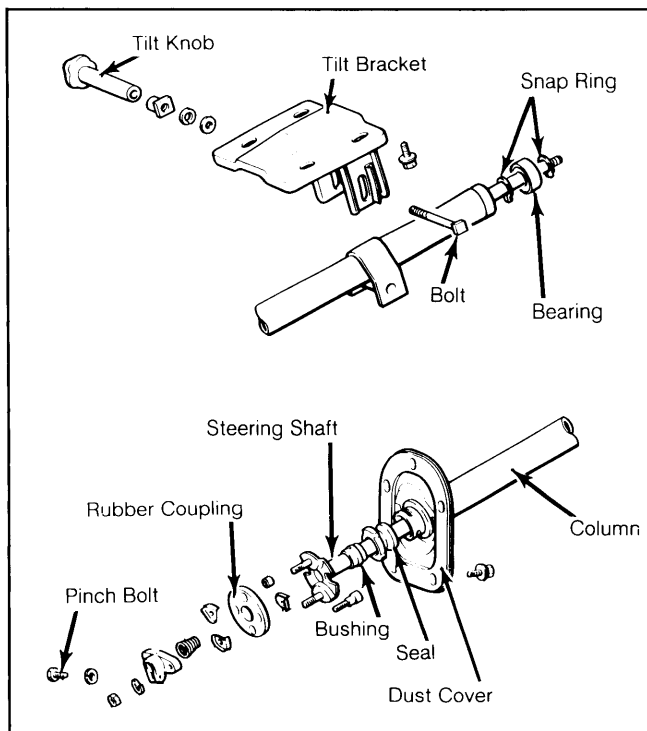

Inspection

1) Check joint cover for cracks or damage. Check steering shaft length. On Pickup models, length should be 29.45-29.53" (748-750 mm). On Challenger and Sapporo models, the shaft length should be 28.62" (726.9 mm).

2) On Pickup models, check steering shaft-to-column bearing clearance. Clearance should be .0004-.0020" (.010-.050 mm). On all models, check steering shaft bend using a dial indicator. Distortion should not exceed .020" (.50 mm).

3) On Pickup models, check steering coupling for damage. Check tilt bracket for wear or cracks. On all other models, check collapsible tube for damage.

4) Hold lower end of steering shaft and move upper shaft to see if there is free play between splines of upper and lower shaft. Check upper and lower column bearings for wear or damage.

5) Check column tube bushing stop for wear or damage. Replace bushing if wear is excessive or if bushing is damaged. Check tilt bracket for wear or cracks.

Reassembly

1) On Challenger and Sapporo models, install column tube bushings onto upper and lower column tubes until bushing stop seats in column tube end. Tighten column tube clamp bolt.

2) Align column tube hole with wheel lock guide dowel. Install steering wheel lock. Insert key and check for proper operation of steering lock. Tighten shear bolts until bolt heads twist off.

3) Coat inside of steering shaft bearing with grease. Install bearing onto steering shaft lower end with flanged surface facing upward. Insert big joint retaining pin and press into place using a hand press.

CAUTION: Make sure that bearing is installed in correct position. Check joint pin for correct installation and check to see that bearing rotates freely.

4) Apply grease to joint socket. Insert spring seats and spring. Hold steering shaft upright. Press down on shaft and insert small joint retaining pin by hand.

NOTE: Check for free play when steering shaft and socket are turned in direction of rotation.

5) Position joint pin retainer on joint socket. Install the stoppers. Install joint cover. Insert steering shaft into column tube.

6) Wipe off grease from outer surface of bearing retainer (rubber) and inner surface of column. Install bearing. Apply a thin coat of adhesive to end of column.

NOTE: Do not allow adhesive to contaminate bearing journal.

7) Position spacer and stopper on steering shaft and insert snap ring. Insert tilt lever screw into tilt lever. Turn tilt lever screw until there is a distance of 1.9-2.1" (50-53 mm) between tilt lever and tilt screw. See Fig. 3.

Fig. 3: Setting Distance Between Tilt Lever Screw and Tilt Lever

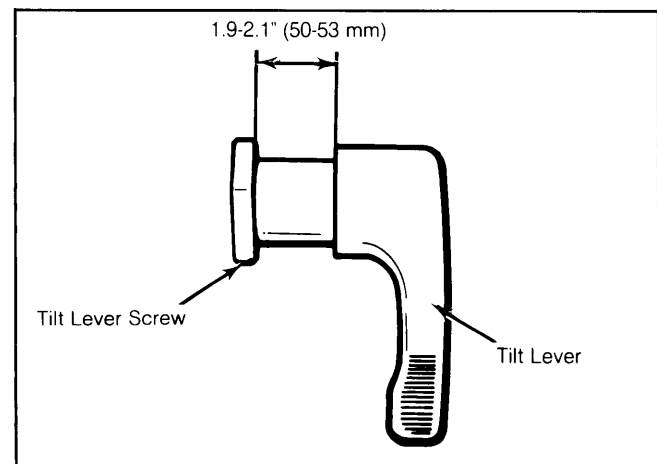

8) Mount tilt bracket on column tube. Insert tilt bolt and lock tilt lever into position as shown in Fig. 4. Place block onto tilt bolt in order to lock the bolt. Insert washer and nut on tilt bolt and tighten.

CHRYSLER CORP. IMPORTS RWD MODELS (Cont.)

Fig. 4: Installing Tilt Bolt and Lock Tilt Lever into Tilt Bracket

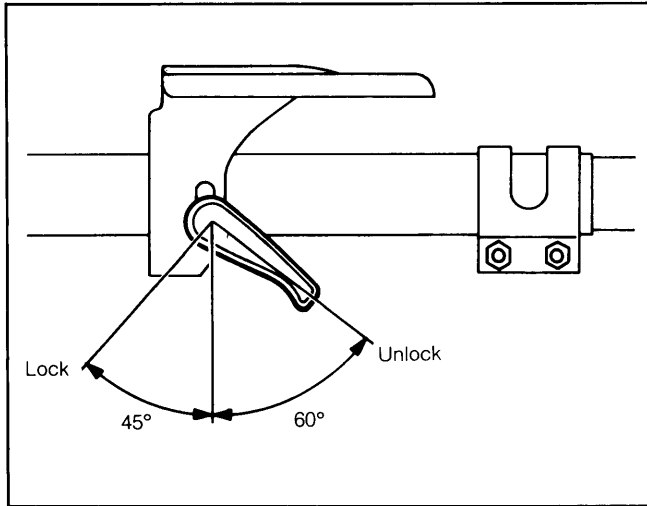

9) On Pickup models, apply grease to shaft bearing, sliding surface of dust seal and bushing. Attach coupling and yoke to lower end of steering shaft.

10) Align tab on dust seal with groove on column tube. Insert steering shaft into column tube. Install snap ring into groove on steering shaft.

11) Position tilt bracket on column tube. Insert spacers between column tube and tilt bracket. Insert bolt through tilt bracket and spacer. Install plain washer, spring washer, plain washer and tilt lock knob. Tighten tilt lock knob.

12) Align column tube with lock guide dowel. Install steering wheel lock temporarily. Insert ignition key and check for proper operation of steering lock.

CAUTION: Securely tighten steering lock retaining bolts after steering shaft is installed.

TIGHTENING SPECIFICATIONS

Application	Ft. Lbs. (N.m)
Steering Shaft Clamp	
Pickup	11-14 (15-19)
All Others	15-18 (20-24)
Steering Wheel Nut	25-33 (34-45)
Column Tube Clamp Bolt	4-6 (5-8)
Tilt Bracket Mounting Bolt	
Pickups	6-9 (8-12)
All Others	4-6 (5-8)