

VOLKSWAGEN

Dasher
Jetta
Rabbit

Rabbit Pickup
Scirocco
Vanagon

DESCRIPTION

Brake systems are hydraulically actuated using a tandem master cylinder and optional power brake unit. All models are equipped with front disc brakes and self-adjusting rear drum brakes. Jetta, Rabbit and Rabbit Pickup models are equipped with a brake proportional valve and all other models are equipped with a pressure regulator in rear brake circuit to avoid rear wheel lock-up. All models are equipped with cable actuated parking brake which operates on rear brakes.

ADJUSTMENT

PEDAL HEIGHT

Dasher — Pedal height is measured from center of brake pedal pad to bottom of steering wheel. To adjust, loosen clevis lock nut and turn push rod until distance is 23.8" (605 mm). Tighten lock nut.

PEDAL FREE PLAY

NOTE — Pedal free play is adjusted at the power brake unit on all models except Dasher. Power brake unit (if equipped) must be removed to adjust free play.

STOP LIGHT SWITCH

Jetta, Rabbit & Rabbit Pickup — Stop light switch is located under dash, above brake pedal. To adjust, loosen lock nuts and adjust switch so distance between brake pedal arm and switch body is .20-.24" (5-6 mm). Tighten lock nuts. See Fig. 1.

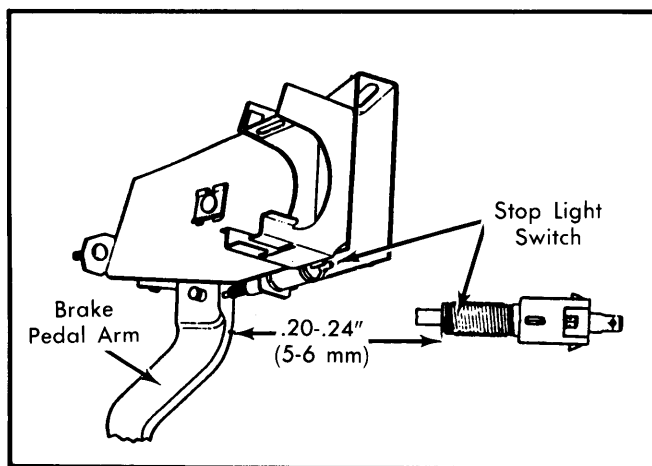

Fig. 1 Adjusting Stop Light Switch on Jetta, Rabbit and Rabbit Pickup Models

PARKING BRAKE

Dasher & Vanagon — Raise and support vehicle and ensure rear brakes are properly adjusted. From under vehicle, loosen parking brake cable lock nut(s). Pull parking brake handle up 2 notches (2-4 notches on Vanagon) and tighten cable adjusting nut(s) until rear wheels lock. Tighten lock nut(s) and ensure rear wheels rotate freely with parking brake fully released.

All Others — Raise and support vehicle and ensure rear brakes are properly adjusted. Pull back rubber (plastic) boot at base of parking brake handle and loosen parking brake cable lock nuts. Pull handle up 2 notches and tighten each adjusting nut until rear wheels lock. Tighten lock nuts and refit boot. Ensure rear wheels rotate freely with parking brake fully released.

BRAKE WARNING LIGHT

A dual warning light is mounted on dash. Light should glow when parking brake lever is pulled 1 notch and go off when lever is fully released (ignition on). To check circuit warning operation, release parking brake (ignition on) and ensure light is off. Open bleed screw on 1 wheel and depress brake pedal; light should glow. Close bleed screw, replenish brake fluid and bleed hydraulic system.

NOTE — Jetta, Rabbit and Rabbit Pickup models are equipped with warning sensor which is connected to brake proportioning valve. This sensor DOES NOT indicate fluid level in master cylinder. All other models are equipped with sensor which indicates fluid level in reservoir.

BRAKE PROPORTIONING VALVE

Jetta, Rabbit & Rabbit Pickup - 1) Valve is located below master cylinder. Connect a 1500 psi (110 kg/cm²) gauge to left front caliper and another gauge to right rear wheel cylinder. Bleed gauges and depress brake pedal several times.

2) Apply brake pedal until front gauge reads indicated pressure for first reading in Brake Pressure Chart. Record rear gauge reading. Increase pedal pressure until front gauge reads indicated pressure for second reading. Record rear gauge reading. Remove gauges and bleed hydraulic system. If pressures do not meet specifications, replace proportioning valve.

BRAKE PRESSURE REGULATOR

Dasher & Scirocco - 1) Regulator is located on right rear frame on Dasher and left rear frame on Scirocco. Empty vehicle, fill fuel tank and load driver's seat to 165 lbs. Bounce car several times and allow vehicle to settle normally.

2) Measure distance from top of tire rim to lower edge of fender lip (both sides). Attach spring tensioners to hold vehicle in settled position. See Fig. 2. Raise and support vehicle, check measurement and adjust tensioners if required. Connect a 1500 psi (110 kg/cm²) gauge to left front caliper and another gauge to right rear wheel cylinder. Bleed gauges.

3) Pump pedal several times. Depress brake pedal until front gauge reads indicated pressure for first reading in Brake Pressure Chart. Record rear gauge reading. Increase pedal pressure until front gauge reads indicated pressure for second reading. Record rear gauge reading.

4) If both pressures were high on rear wheel, loosen regulator clamp bolt and REDUCE spring tension. INCREASE spring tension if pressures were too low. Replace pressure regulator if spring adjustment does not correct pressures.

NOTE — Do NOT adjust spring tension with brake pedal depressed.

VOLKSWAGEN (Cont.)

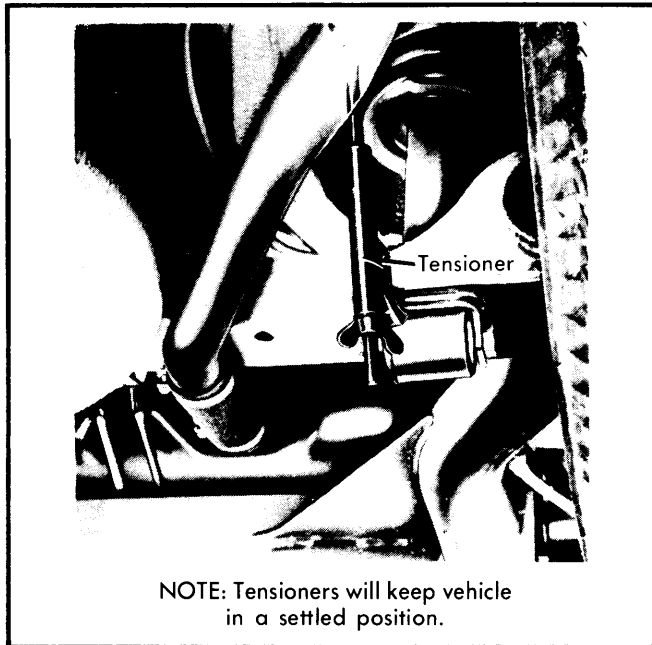

NOTE: Tensioners will keep vehicle in a settled position.

Fig. 2 Tensioner Installed to Shock Absorber Mount

Vanagon - 1) Regulator is mounted on right rear frame. Raise and support vehicle and connect a 1500 psi (110 kg/cm²) gauge to left front caliper and another gauge to left rear wheel cylinder. Bleed gauges and depress brake pedal several times.

2) Remove regulator attaching nuts, then remove regulator from mounting studs. Depress brake pedal until front gauge reads indicated pressure for first reading in Brake Pressure Chart. Maintain pressure and tilt front of regulator down at a 30° angle. Increase pedal pressure until front gauge reads indicated pressure for second reading. Record rear gauge reading.

NOTE - Do not damage brake lines when tilting regulator.

3) If pressures are as specified in Brake Pressure Chart, return and secure regulator to proper position. Remove gauges and bleed hydraulic system. If pressures are not as specified, replace regulator.

Brake Pressure Chart

Application	Front Gauge psi (kg/cm ²)	Rear Gauge psi (kg/cm ²)
Dasher		
1st Reading	710 (50)	440-497 (31-35)
2nd Reading	1422 (100)	753-810 (53-57)
Rabbit Pickup		
1st Reading	725 (51)	478-594 (34-42)
2nd Reading	1450 (102)	739-884 (52-62)
Vanagon		
1st Reading	725 (51)	725 (51)
2nd Reading	1450 (102)	798-943 (56-66)
All Other Models		
1st Reading	725 (51)	420-536 (30-38)
2nd Reading	1450 (102)	681-884 (48-62)

REMOVAL & INSTALLATION

FRONT DISC BRAKE PADS

NOTE - ATE, Girling or Kelsey-Hayes calipers may be used on front disc brakes. Dasher is equipped with new type Girling calipers. Disc pads are interchangeable between ATE and Girling calipers only.

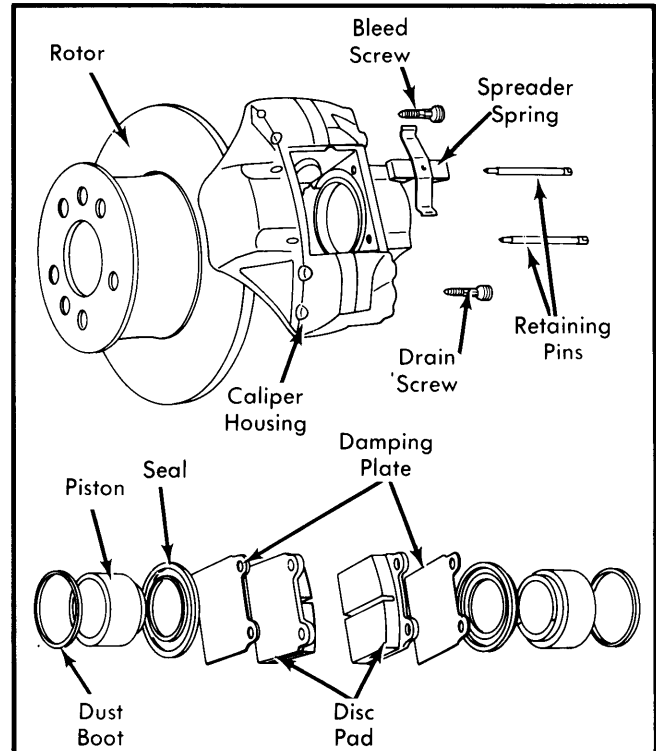

Fig. 3 ATE Disc Brake Assembly - Vanagon

Removal (ATE) - 1) Raise and support vehicle; remove tire and wheel. Remove retaining clip (if equipped) and remove retaining pins and spreader spring. Using a disc pad extractor (US 1023/3), remove inner brake pad.

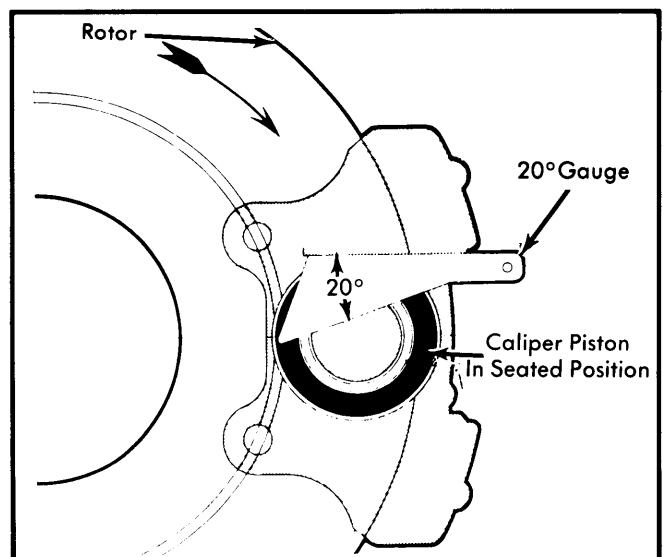

Fig. 4 Using a 20° Gauge to Position Piston in ATE Caliper Bore (Except Vanagon)

VOLKSWAGEN (Cont.)

2) Separate outer pad from notch in piston, then extract outer brake pad. Remove damping plates. Replace brake pads if thickness is less than .08" (2 mm) on Vanagon or .25" (6 mm) on all other models.

Installation — 1) Siphon small amount of brake fluid from master cylinder reservoir. Seat piston in bore with compressor (US 1023/4). Check position of piston. On Vanagon, notches in piston must face bottom of caliper; rotate with pliers (US 1023/2) if required. On all others, use 20° gauge to position piston. See Fig. 4.

2) Install noise damping plates with lugs engaged in piston recesses. Install brake pads and new spreader spring. Install retaining pins and clips (if equipped). Depress brake pedal several times to set pad-to-rotor clearance.

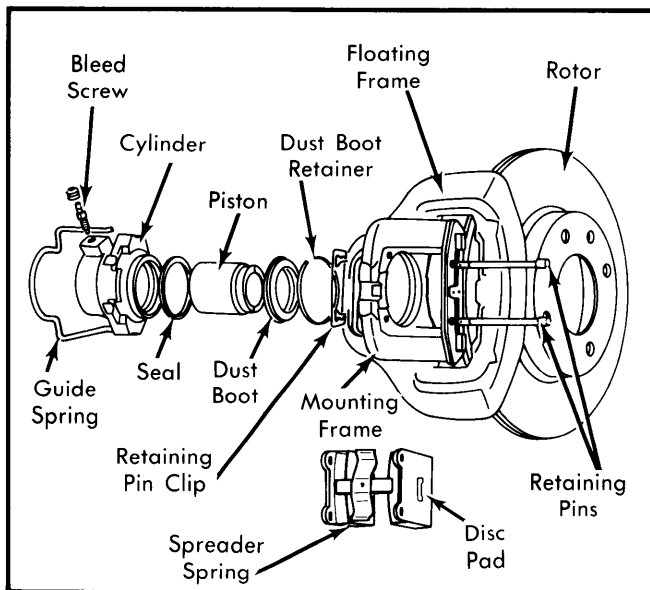

Fig. 5 ATE Disc Brake Assembly — Except Vanagon

Removal (Girling; Exc. Dasher) — 1) Raise and support vehicle; remove tire and wheel. Remove spreader spring. Remove pin retaining bolt (pin clips) and remove pad pins.

2) Using extractor tool (US 1023/3), remove pads and damping plates (if equipped). Replace brake pads if thickness or friction material is less than .08" (2 mm).

Installation — 1) Remove small amount of brake fluid from reservoir. Seat pistons in caliper bore with suitable tool. Install pads and damping plates (if equipped). Damping plates must be installed with arrows pointing in forward wheel rotation.

2) Attach spreader spring (if stamped with an arrow, install with arrow pointing down). Install pad pins and pin retaining bolt (pin clips). Depress brake pedal several times to adjust pad-to-rotor clearance.

Removal (Girling; Dasher) — 1) Raise and support vehicle on safety stands; remove tire and wheel. Remove small amount of brake fluid from reservoir. Using hand pressure, seat piston in housing by pushing caliper toward outer bearing.

2) Remove lower caliper mounting bolt while holding guide pin head with open end wrench. Rotate caliper body upward and remove pads. Replace pads if lining is less than .28" (7 mm).

Installation — To install, reverse removal procedure and install new lower mounting bolt. Depress brake pedal several times to adjust pad-to-rotor clearance.

Removal (Kelsey-Hayes) — Raise and support vehicle on safety stands; remove tire and wheel. Remove anti-rattle springs and guide pins. Remove and suspend caliper with wire. DO NOT allow caliper to hang from hydraulic line. Remove pads.

Installation — Insert pads in caliper support (inner pad is identified by chamfered ends). Remove brake fluid from reservoir and seat piston with suitable tool. Position caliper on support. Lube guide pins with silicone grease and install (long pin on top). Install anti-rattle springs. Depress brake pedal several times to adjust pad-to-rotor clearance.

DISC BRAKE CALIPER

Removal — Raise and support vehicle and remove wheel. Disconnect brake line from caliper and plug opening to prevent entry of dirt and foreign matter. Bend back locking tabs (if equipped) on mounting bolts. Remove caliper mounting bolts and take off caliper assembly.

Installation — To install, reverse removal procedure, using new lock plates and mounting bolts.

DISC BRAKE ROTOR

Removal (Vanagon) — Remove grease cap, cotter pin and loosen adjusting nut. Raise and support vehicle on safety stands. Remove wheel and tire. Remove wheel bearing hardware. Remove and suspend brake caliper. Pull hub and rotor from spindle without dropping bearing.

Removal (All Other Models) — Raise and support vehicle on safety stands. Remove wheel and tire. Remove and suspend brake caliper. Remove countersunk screw from between 2 wheel bolt holes. Pull rotor off hub.

Installation (All Models) — To install, reverse removal procedure. On Vanagon, adjust wheel bearings. See *Wheel Bearing Adjustment* in SUSPENSION Section.

REAR BRAKE DRUM

CAUTION — Loosen and tighten spindle nut only with wheels on the ground.

Removal (Vanagon) — Remove dust cap, cotter pin and loosen castellated nut. Raise and support vehicle; remove tire and wheel. Release parking brake at equalizer and back off adjuster. Remove drum retaining screws. Install puller and remove drum.

NOTE — Drum must rotate freely during removal.

Installation — To install, reverse removal procedure and ensure drum retaining screws are tight. Adjust parking brake and depress brake pedal several times to set self-adjusting mechanism.

VOLKSWAGEN (Cont.)

Removal (All Others) — Raise and support vehicle. Remove 1 wheel bolt and push adjusting wedge upward with a screwdriver. Reinstall wheel bolt, remove wheel bearing hardware and remove drum assembly from spindle without dropping thrust washer or outer bearing.

Installation — To install, reverse removal procedure and adjust wheel bearings. See *Wheel Bearing Adjustment in SUSPENSION Section*. Apply brake pedal firmly several times to set self-adjusting mechanism.

BRAKE SHOES

Removal (Vanagon) — 1) With wheel and drum removed, remove hold down springs and pins. Disconnect parking brake cable from lever on brake shoe. Remove lower return spring and adjuster spring.

2) Move brake shoes out of lower support and remove return springs. Remove brake shoes as an assembly from backing plate without pulling pistons out of wheel cylinder. Separate brake shoes and disconnect parking brake lever from brake shoe. Remove lower support bolts and support.

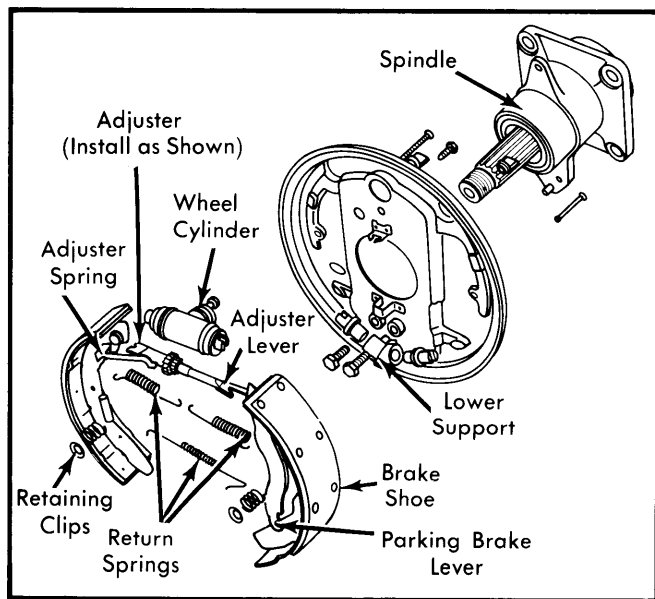

Fig. 6 Vanagon Rear Brake Assembly

Installation — 1) To install, reverse removal procedure and note the following: After installing brake shoes, adjust brake shoes by setting distance (measured from outer surface of each brake lining) to 9.87" (250.7 mm).

2) Adjust parking brake at equalizer (there must not be any free play between parking brake lever on brake shoe and adjusting rod). Install brake drum and depress brake pedal several times to set self-adjusting mechanism.

Removal (All Others) — 1) With drum removed, remove hold down springs and pins. Remove brake shoes from anchor pins and remove return spring.

2) Disconnect parking brake cable from lever. Disconnect adjusting wedge spring and upper return spring. Remove brake shoes. Place adjuster strut and shoe in vise; remove tension spring. Separate shoe and components.

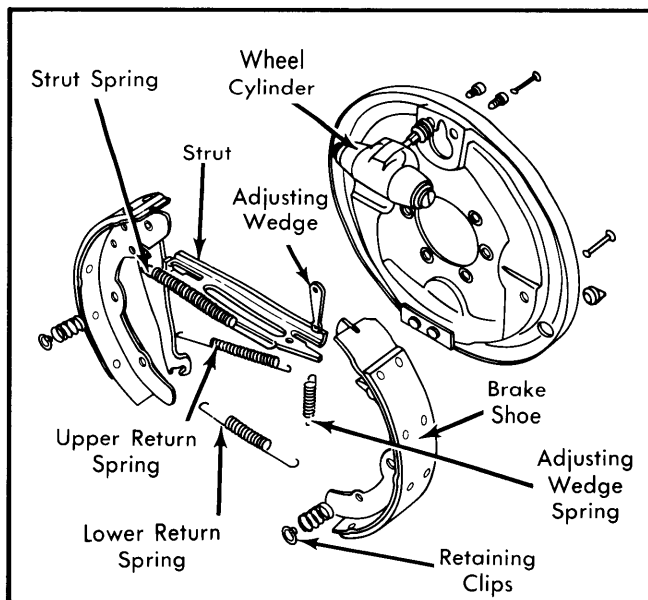

Fig. 7 Rear Brake Assembly (Except Vanagon)

Installation — To install, reverse removal procedures. Lug on adjusting wedge faces backing plate. Adjust wheel bearings. See *Wheel Bearing Adjustment in SUSPENSION Section*. Apply brake firmly to set self adjusting mechanism.

MASTER CYLINDER

NOTE — Removal and installation of all master cylinders is basically the same. The following variations may apply: Location of cylinder, removal of wheel for accessibility, number of fluid connections, and number of electrical connections.

Removal (Vanagon) — 1) Remove instrument panel, then drain or siphon fluid from master cylinder reservoir. Disconnect fluid lines and electrical connections from master cylinder. Remove vacuum lines from power brake unit. Remove pedal and bracket assembly.

2) Disconnect brake push rod from brake pedal. Remove power brake unit and master cylinder assembly from pedal bracket. Remove master cylinder-to-power brake unit attaching bolts and remove master cylinder.

Installation — To install, reverse removal procedure and note the following: Install a new "O" ring between master cylinder and power brake unit. Adjust brake push rod length. See *POWER BRAKE UNIT*. Bleed hydraulic system.

Removal (All Others) — Drain or siphon fluid from reservoir. Raise and support vehicle and remove cover plate (if equipped). Disconnect fluid lines and electrical connections at master cylinder. On models without power unit, remove brake push rod from brake pedal. Remove master cylinder-to-power brake unit attaching bolts and remove master cylinder.

NOTE — If spacers are used on attaching bolts, do not drop or lose spacers.

VOLKSWAGEN (Cont.)

Installation — To install, reverse removal procedure. Install a new "O" ring between master cylinder and power brake unit. Adjust brake pedal height on Dasher. After installation, bleed hydraulic system.

POWER BRAKE UNIT

Function Test — Depress and release brake pedal several times (engine off) to exhaust vacuum. Depress and hold pedal; start engine. Pedal should fall slightly then hold. Replace booster assembly if check valve is operative and no defects or leaks are present in vacuum or hydraulic systems.

Removal (Vanagon) — Remove instrument panel and separate power brake unit from master cylinder as previously described.

Installation — 1) To install, reverse removal procedure and note the following: Before installing brake push rod to brake pedal, adjust push rod length.

2) To adjust push rod length (measured from power unit flange to centerline of push rod clevis), loosen lock nut and turn push rod until distance is 4.39" (111.5 mm). Tighten lock nut. Complete installation and bleed hydraulic system.

Removal (All Others) — Remove master cylinder from power brake unit as previously described. Disconnect brake push rod from brake pedal. Disconnect vacuum lines from power brake unit. Remove mounting nuts from firewall and remove power brake unit.

Installation — To install, reverse removal procedure. Always replace damping ring, washer, filter and "O" ring. Slots in damping washer and filter must be offset 180°.

CHECK VALVE

Function Test — Check valve is located in vacuum line between power brake unit and intake manifold. Blowing into large diameter side must unseat valve; valve must seat when test is performed on opposite side. Replace defective valve.

**VACUUM BOOSTER
(CIS FUEL INJECTED MODELS ONLY)**

1) An adjustable or non-adjustable vacuum booster is installed to increase vacuum to power brake unit. To check booster, warm engine until oil reaches 140°F. Install "T" connector between distributor vacuum unit and intake manifold. Gauge should read 7.4" (188 mm) vacuum with engine idling. If not, check vacuum lines for leaks.

2) If vacuum is as specified in step 1), check booster as follows: Remove and plug hose from right side of booster. Loosen lock nut (if equipped) and install vacuum gauge and hose. Gauge should read 11.8" (300 mm) vacuum with engine idling. Adjust screw in or out to obtain correct reading (if equipped). Replace defective booster.

**VACUUM PUMP
(DIESEL ONLY)**

Removal & Installation — Remove vacuum lines from upper housing. Remove unit from engine block. To install, reverse removal procedure and replace "O" ring at mounting base.

OVERHAUL**DISC BRAKE CALIPER**

Disassembly (ATE & Girling; Vanagon) — 1) Remove disc pads and damping plates as previously described. Clamp mounting flange in a soft-jawed vise and remove dust boot retainer (if equipped) and dust boot.

2) Install piston retainer tool (US 1023/5) on 1 piston. Insert wooden block in caliper and remove piston with compressed air. Repeat procedure for opposite piston. Remove piston seals without damaging bore.

Cleaning & Inspection — Clean all parts in brake fluid. Check piston and caliper bore for wear or damage; replace as necessary. DO NOT split caliper housings; assembly must be replaced if split. Replace all parts included in repair kit.

Reassembly — Apply light coat of brake paste to piston and seal. Fit seal in groove, install piston in bore and press into bore using retainer (US 1023/5). Lightly coat inside of dust boot with brake paste and fit to piston. Using press clamp (VW 442), press dust cap onto bore groove and seat piston. Install dust boot retainer (if equipped). Install damping plates. Repeat procedure for other piston.

NOTE — Ensure pistons are properly seated and piston damping plates are properly installed on ATE calipers.

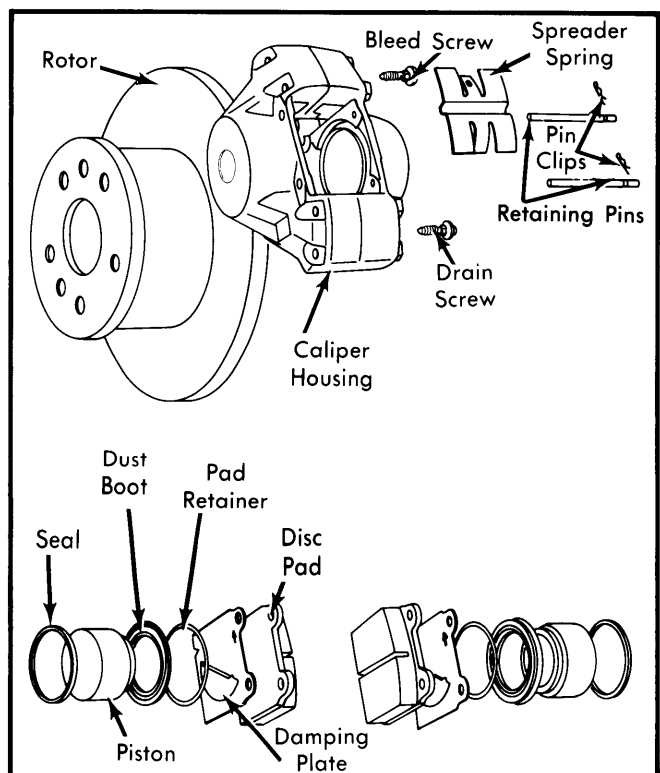

Fig. 8 Girling Disc Brake Assembly — Vanagon

VOLKSWAGEN (Cont.)

Disassembly (ATE; All Others) – 1) Remove disc pads as previously described. Press caliper frame off floating frame. Insert wooden block in floating frame and drive cylinder and guide spring off with brass drift.

2) Remove piston retaining ring and dust seal. Protect piston with wooden block and force piston out with compressed air. Remove piston seal without damaging bore.

Cleaning & Inspection – Clean all parts in brake fluid. Check piston and bore for wear or damage; replace as necessary. Replace all parts included in repair kit.

Reassembly – Reverse disassembly procedure and note the following: Coat piston with brake paste. Use a vise to seat piston. Use a brass drift to fit brake cylinder to floating frame. Make sure both grooves in mounting frame are pushed over ribs on floating frame. Make sure piston is properly positioned. See Fig. 4.

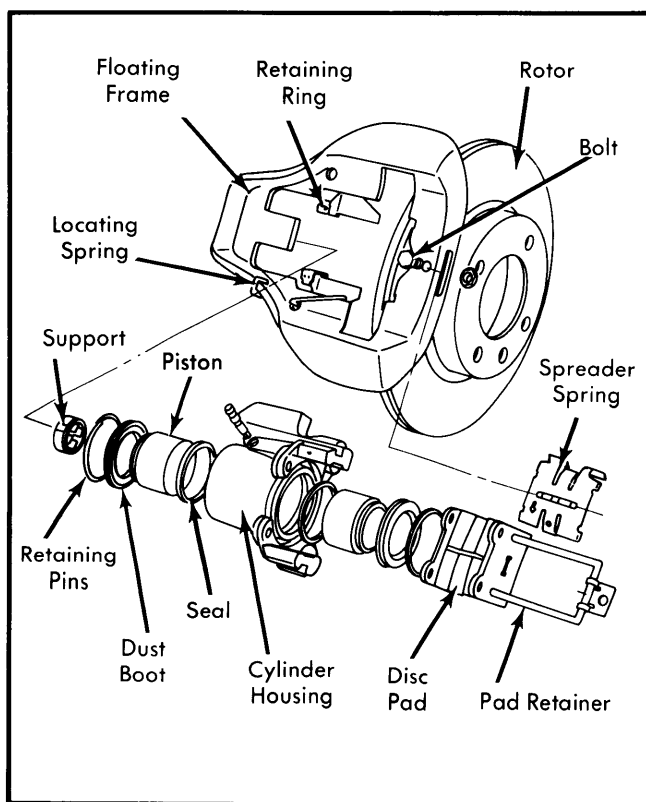

Fig. 9 Girling Disc Brake Assembly (Except Dasher and Vanagon)

Disassembly (Girling; Except Dasher) – Press cylinder out of frame. Remove dust boot and retaining ring from each piston. Hold piston between padded jaws of vise and blow pistons out of bore with compressed air. Remove piston seals without damaging bore.

Cleaning & Inspection – Clean all parts in brake fluid. Check piston and caliper bore for wear or damage; replace as necessary. Replace all parts included in repair kit.

Reassembly – To reassemble, reverse disassembly procedure and note: Coat pistons and seals with brake paste before refitting.

Disassembly (Girling; Dasher) – Separate cylinder housing from pad carrier. Remove dust cap. Insert wooden block in housing and blow out piston with compressed air. Remove piston seal without damaging bore.

Cleaning & Inspection – Clean all parts in brake fluid. Check piston and bore; if corroded, pitted or scored, replace defective part. DO NOT use abrasives. Replace all parts included in repair kit.

Reassembly – Coat piston, cylinder bore and new seal with brake paste. Fit seal into cylinder. Slide dust seal onto piston, then slowly insert piston into cylinder, fitting inner lips of dust seal on housing groove. Fully seat piston into cylinder. Engage outer lip of dust seal on groove of piston.

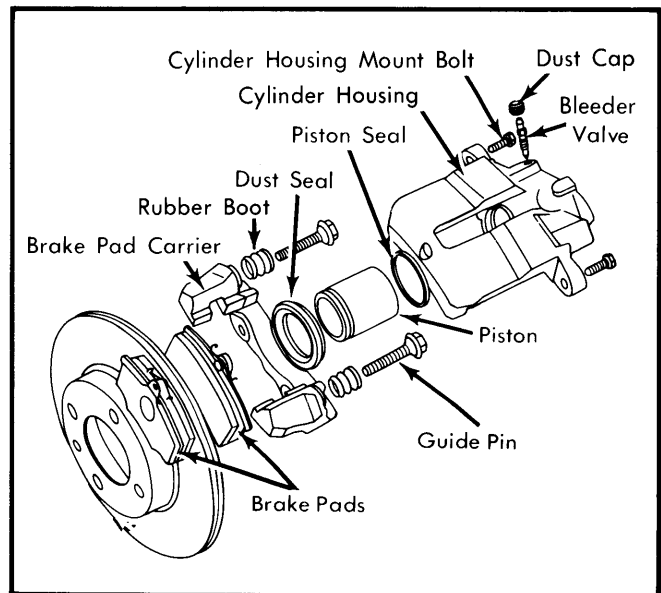

Fig. 10 Girling Disc Assembly Used on Dasher Kelsey-Hayes Disc Assembly is Similar

Disassembly (Kelsey-Hayes) – Disconnect brake hose from caliper. Remove caliper from support assembly. Remove anti-rattle springs and guide pins. Remove support from spindle. Remove dust boot from piston. Place wooden block in caliper housing and blow piston out with compressed air. Remove piston seal without damaging bore. Remove guide pins and bushings, if required.

Cleaning & Inspection – Clean all parts in brake fluid. Check cylinder bore and piston for wear or corrosion; replace defective part. Replace all parts included in repair kit.

Reassembly – Coat seals, dust boot, cylinder bore and piston with brake paste. Coat guide pins with silicone grease. Reverse disassembly procedure and note the following: Seat dust boot with brass drift. Long guide pin is installed in top hole of caliper housing.

VOLKSWAGEN (Cont.)

MASTER CYLINDER

NOTE — Master cylinders differ in external design and primary piston configuration between power assist and non-power assist models. Disassembly procedures are the same.

Disassembly — Remove dust boot (if equipped) and piston stop screw. Remove circlip and washer. Tap open end of cylinder and remove piston assemblies. Remove all external mountings and hardware from cylinder.

Cleaning & Inspection — Clean all parts with brake fluid or denatured alcohol. Check cylinder bore and pistons for wear; replace as complete assembly if defective. Replace all rubber parts during overhaul and use all parts included in repair kit.

Reassembly — Reverse disassembly procedure and note the following: Coat primary piston shaft with lubricant supplied in repair kit. Coat pistons and cups with brake paste. DO NOT interchange return springs or piston cups. (ATE secondary cups are identified by chamfer and groove.)

POWER BRAKE UNIT
PRESSURE REGULATING VALVE
& PROPORTIONING VALVE

NOTE — Manufacturer recommends replacing each unit as complete assembly. DO NOT disassemble.

VACUUM PUMP
(DIESEL ONLY)

Disassembly — 1) Remove cover from upper housing and separate components. Remove upper housing retaining screws and separate housings. Remove diaphragm retaining nut and separate diaphragm and plates.

2) Remove drive shaft cover and gasket. Remove retainer and washer from drive shaft. Push drive shaft back until push rod is free. Remove push rod.

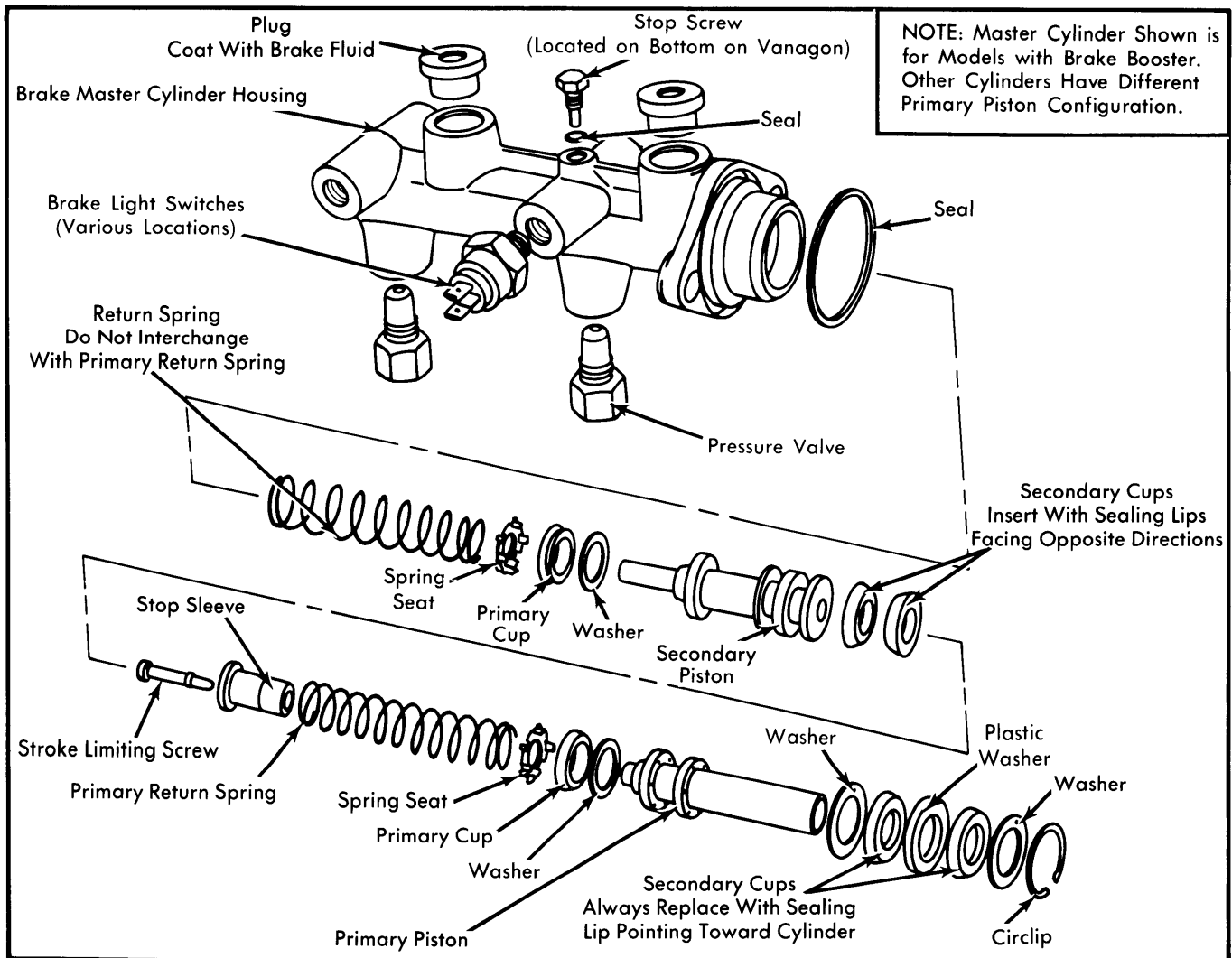

Fig. 11 Exploded View of Master Cylinder

VOLKSWAGEN (Cont.)

Cleaning & Inspection — Clean all parts in denatured alcohol and inspect body for cracks. Inspect diaphragm for cracks and deformation. Replace defective parts as required. Replace diaphragm retaining nut and all rubber parts during overhaul. Use all parts included in repair kit.

Reassembly — **1)** Reassemble diaphragm assembly with diaphragm molded center facing up. Coat new retaining nut with sealing compound and tighten to 60 INCH lbs. (7 N.m). Install upper housing plate with brake booster connection pointing straight up. Loosely install retaining screws.

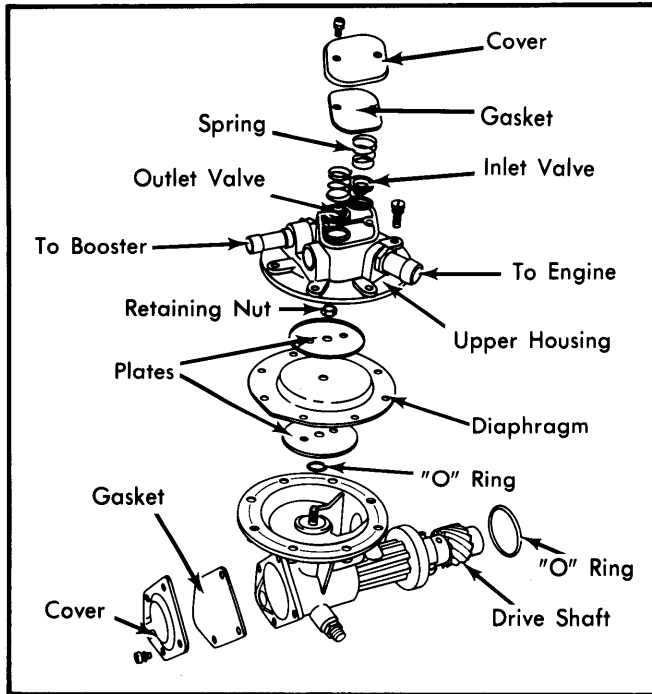

Fig. 12 Exploded View of Diesel Engine Vacuum Pump Assembly

2) Press and hold push rod into position. Tighten upper housing retaining screws. Push drive shaft into position and secure with washer and retainer. Replace spring sealing washers and install valves with spring seat toward housing. Replace gaskets and install covers.

TIGHTENING SPECIFICATIONS

Application	Ft. Lbs. (N·m)
Caliper Mounting Bolts [Ⓛ]	
Dasher (Support Bolt)	43 (58)
Dasher (Caliper-to-Support Bolt)	25 (34)
Vanagon	118 (160)
All Others	36 (49)
Girling Caliper Pad Retainer Bolt	14 (19)
Kelsey-Hayes Guide Pins	30 (41)
Vanagon Rear Brake Shoe Support	48 (65)

[Ⓛ] — New self locking bolts may be used in some cases. Tighten to 50 ft. lbs. (68 N·m).

DISC BRAKE SPECIFICATIONS

Application	Caliper Bore Diameter In. (mm)	Lateral Runout In. (mm)	Parallelism In. (mm)	Original Thickness In. (mm)	Minimum Refinish Thickness In. (mm)	Discard Thickness In. (mm)
Vanagon004 (0.10)512 (13)	.453 (11.5)	.433 (11)
All Others004 (0.10)	.0008 (.02)	.472 (12)	.413 (10.5)	.393 (10)

DRUM BRAKE SPECIFICATIONS

Application	Wheel Cyl. Bore Diameter In. (mm)	Drum Diameter In. (mm)	Original Diameter In. (mm)	Maximum Refinish Diameter In. (mm)	Discard Diameter In. (mm)
Dasher & Rabbit Pickup	7.87 (200)	7.87 (200)	7.90 (200.5)	7.91 (201)
Vanagon	9.92 (252)	9.92 (252)	9.96 [Ⓛ] (253)	9.98 (253.5)
All Others	7.08 (180)	7.08 (180)	7.10 (180.5)	7.13 (181)

[Ⓛ] — Use oversize linings after turning drum .020" (0.50 mm).