

RENAULT

Le Car
18i

DESCRIPTION

Brake system is hydraulically operated using a tandem master cylinder and optional power brake unit. All models are equipped with front disc brakes and rear drum brakes. A pressure limiter valve is installed in rear brake circuit to prevent premature rear wheel lock-up. Parking brake is cable actuated on rear wheels.

ADJUSTMENT

REAR DRUM BRAKE SHOES

Le Car — Two adjusting lugs are located on backing plate. Using a wrench, turn front lug counterclockwise and rear lug clockwise until shoes just contact drum. Then back off adjustment until drum rotates freely.

18i — Adjust brake shoes by pressing down on brake pedal repeatedly.

BRAKE PEDAL FREE PLAY

Le Car — Brake pedal free play (measured at pedal pad center) should be .203" (5 mm). To adjust free play, loosen operating rod lock nut and rotate operating rod until specified free play is obtained. Tighten lock nut.

PARKING BRAKE

Le Car — Adjust service brakes, then fully release parking brake. Loosen lock nut on adjustment rod. Tighten adjustment nut until lining just meets drum. At this point, parking brake lever travel should be about 6 notches. Tighten lock nut and check operation.

18i — Place vehicle on a lift with parking brake handle released. Screw on equalizer nut until cable deflection between secondary cable and vehicle chassis is about .74" (20 mm). Check parking brake lever travel. It should move a minimum of 12 notches.

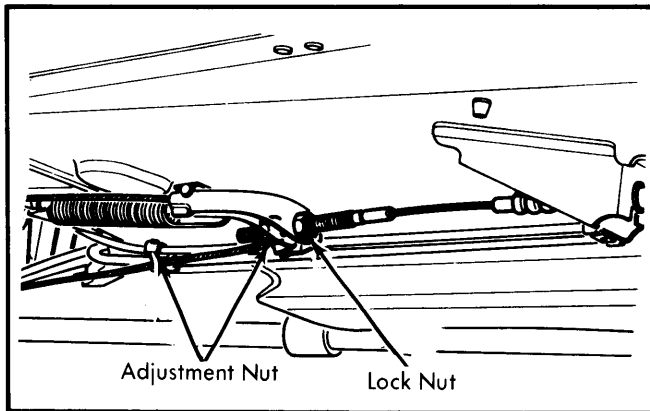

Fig. 1 Le Car Parking Brake Adjustment Points

BRAKE WARNING LIGHT

A dual warning light is mounted on instrument panel. Light should glow when parking brake lever is pulled 1 notch and go off when lever is fully released (ignition on). To check circuit warning sensor, release parking brake (ignition on) and ensure

light is off. Raise master cylinder reservoir cap; light should glow. If not, check bulb or circuit connections.

REAR BRAKE PRESSURE LIMITER

NOTE — Limiter must always be checked and adjusted with vehicle on level ground, fuel tank full, trunk empty and driver's seat occupied.

1) To check limiter, remove 1 rear wheel cylinder bleeder screw and install a pressure gauge (Fre. 214-02 on Le Car, Fre. 214-04 on 18i) into vacant hole. Bleed system through screw on gauge. Depress brake pedal and check pressure at wheel cylinder.

2) Pressure on Le Car should be 405-465 psi (28.5-32.5 kg/cm²) and pressure on 18i should be 435-490 psi (30.6-34.5 kg/cm²). Release lock nut and tighten adjustment nut to increase pressure or loosen it to reduce pressure. Apply brake pedal several times and recheck adjustment. Remove pressure gauge and bleed system.

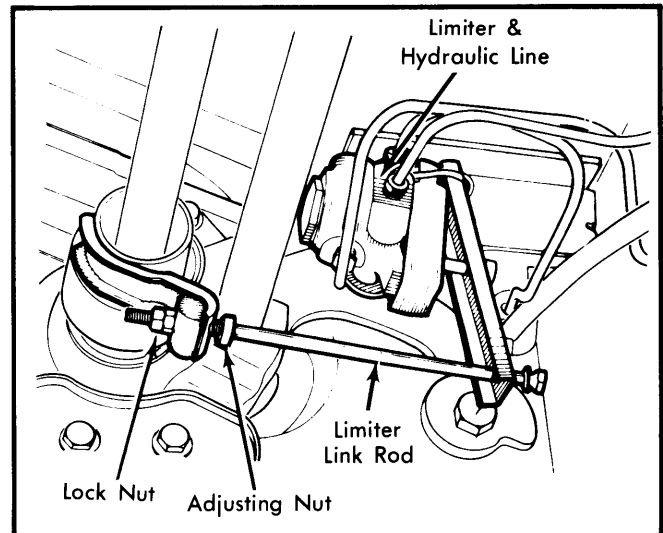

Fig. 2 Pressure Limiter Adjustment Points (Le Car Shown, 18i Similar)

REMOVAL & INSTALLATION

FRONT DISC PADS

Removal & Installation (Le Car) — Caliper must be removed to remove brake pads. See Disc Brake Caliper Removal & Installation.

Removal (18i) — Raise and support vehicle. Disconnect pad wear warning light wires. Take out retaining clip and remove key. With a screwdriver, gently pry between rotor and caliper at outer pad to push caliper piston back slightly. Remove pads.

Installation — Push caliper piston back with clamp (Fre.823). Put the 2 anti-squeal pins in place on new pads. Position pads in caliper bracket and engage key after having chamfered entry end of key. Put clip on key. Reconnect wear-warning light wires. Press down brake pedal several times to seat pads.

RENAULT (Cont.)

FRONT DISC CALIPER

Removal (Le Car) — Raise and support vehicle and remove front wheels. Remove spring clips and slide keys out of caliper and mounting bracket. Disconnect brake line fitting from flexible hose and remove hose retaining clip from body. Remove caliper from mounting bracket and disconnect flexible hose from caliper. Remove brake pads and pad spring from caliper.

Installation — To install, reverse removal procedure and note the following: Install longest pad spring on outside of caliper. Tighten all fittings and bleed hydraulic system.

Removal (18i) — Raise and support vehicle and remove wheel and tire. Remove brake pads. Disconnect hydraulic line. Remove 2 caliper bolts remove caliper.

Installation — To install, reverse removal procedure and bleed brake system.

FRONT DISC ROTOR

Removal (Le Car) — Remove caliper as previously described and remove caliper mounting bracket. Attach holding tool (Rou. 604 or Rou. 436-01) to wheel studs and remove axle shaft nut. Attach slide hammer to hub and remove hub and rotor assembly. Remove hub-to-rotor bolts and remove rotor from hub.

Installation — To install, reverse removal procedure and tighten hub-to-rotor bolts evenly. Bleed hydraulic system if required.

Removal (18i) — Raise and support vehicle and remove brake pads and caliper. Remove inset bolts and remove disc.

NOTE — In some cases it may be necessary to slightly loosen drive shaft nut in order to remove disc.

Installation — Put the new disc in place on hub and attach with bolts. If necessary, torque drive shaft nut while holding hub with hub locking tool (Rou. 604). Install the caliper and tighten bolts. Install brake pads.

REAR BRAKE DRUM

Removal (Le Car) — Raise and support vehicle. Remove hub grease cap, cotter pin, nut and washer. Back off brake shoe adjuster. Attach slide hammer and remove drum.

Installation — To install, reverse removal procedure. Lubricate wheel bearings and adjust. See *Wheel Bearing Adjustment in SUSPENSION Section*.

Removal (18i) — Loosen parking brake. Remove dust plug from backing plate. Put a screwdriver against parking brake lever and push to free its peg from brake shoe. Loosen lever by pushing toward rear. Remove grease cap, cotter pin, lock nut, drum hub nut and washer. Remove drum and outer wheel bearing.

Installation — 1) Grease bearings and place drum in place with outer bearing, drum hub and nut. Adjust bearings. See *Wheel Bearing Adjustment in SUSPENSION Section*.

2) Install castle lock nut and cotter pin. Put on grease cap filled with grease. Adjust brake shoes by pressing down on the brake pedal repeatedly. Adjust parking brake. Reinstall dust plug on backing plate.

REAR BRAKE SHOES

Removal & Installation — Remove wheel and brake drum from vehicle. Install wheel cylinder clamp, then remove upper brake shoe return spring. Disconnect parking brake cable from actuator lever. Remove parking brake actuator link and lower return spring. Unhook shoe hold-down springs and remove brake shoes. To install, reverse removal procedure.

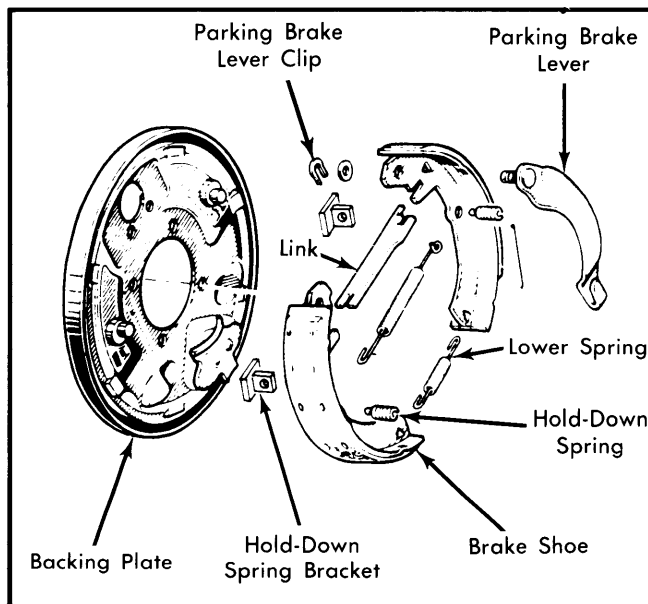

Fig. 3 Exploded View of Brake Shoe Assembly (Le Car Shown, 18i Similar)

MASTER CYLINDER

Removal (Le Car) — Drain fluid from master cylinder and disconnect and plug hydraulic lines. Remove pressure loss indicator bolt (if equipped). Disconnect push rod from brake pedal (without power brake unit). Remove mounting hardware and remove master cylinder.

Installation — To install, reverse removal procedure and adjust brake pedal free play. Bleed and adjust hydraulic system.

Removal (18i) — Drain fluid reservoir and remove the reservoir along with rubber hose rings. Unscrew brake lines and mark their positions on master cylinder. Remove 2 attaching nuts on brake booster. Remove master cylinder.

Installation — Check master cylinder operating clearance. The piston rod projection length should be .354" (9 mm). Attach master cylinder to brake booster. Attach hydraulic lines in the following order: right front wheel, left front wheel, left rear wheel and right rear wheel. Bleed brake system.

POWER BRAKE UNIT

NOTE — Power brake unit is not serviceable, only the air filter and check valve can be serviced.

Removal (Le Car) — Disconnect battery and remove fluid from master cylinder. Remove engine air cleaner (if necessary). Disconnect hydraulic lines at master cylinder, and remove pressure loss indicator valve bolt (if equipped). Disconnect vacuum hose and remove clevis from brake pedal. Remove power brake unit attaching nuts from pedal side of firewall. Remove master cylinder and power cylinder as an assembly. Separate master cylinder from power brake unit.

RENAULT (Cont.)

Removal (18i) — Remove master cylinder from vehicle. Remove brake pedal push rod adjuster link pin. Remove brake booster attaching nuts on firewall. Remove brake booster from vehicle, saving support spacer.

Installation (All Models) — To install reverse removal procedure and adjust push rod-to-master cylinder clearance. Clearance should be .36" (9.13 mm) on Le Car and .35" (9.0 mm) on 18i. On all models, bleed hydraulic system.

Check Valve Replacement — Check valve is located on power brake unit. To replace, remove vacuum input line and pull and turn check valve out of power unit. Install new check valve by pushing and turning to seat valve. Reconnect vacuum line.

OVERHAUL

NOTE — Master Cylinder, Power Brake Unit, and Brake Pressure Limiter cannot be Overhauled.

FRONT CALIPER

Disassembly — Remove caliper from vehicle and remove piston dust cover. Using compressed air introduced through caliper fluid inlet, carefully remove piston from caliper assembly. Remove piston seal from cylinder. On Le Car, use a wedge to slightly spread legs of caliper piston bracket a small amount. Remove caliper stop peg from piston bracket. Slide cylinder assembly from bracket.

Cleaning & Inspection — Clean all parts in denatured alcohol and inspect for piston and cylinder wear. Replace worn parts as required. Replace all rubber seals during overhaul.

Reassembly — Lubricate cylinder bore, piston, and seals with brake fluid prior to reassembly. To reassemble, reverse disassembly procedure.

WHEEL CYLINDER

Disassembly & Reassembly — Remove dust boots, pistons, cups and spring. Examine components for damage or excessive

wear. Replace worn parts as required. Before reassembly, dip pistons and cups in clean brake fluid.

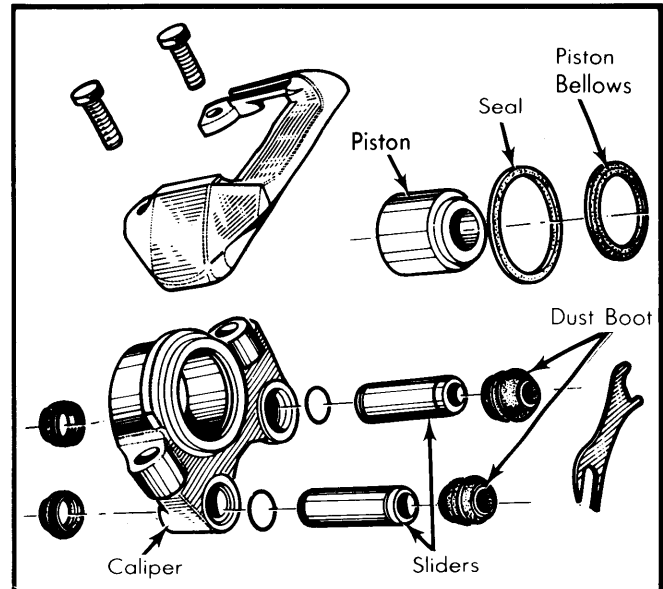

Fig. 4 Exploded View 18i Caliper Assembly

TIGHTENING SPECIFICATIONS

Application	Ft. Lbs. (N.m)
Caliper Bracket Bolts	
Le Car	50 (68)
18i	74 (101)
Caliper Attaching Bolts	
18i	44 (60)
Rotor-to-Hub	
Le Car	20 (27)
Drive Shaft Nut	
Le Car	90 (122)
18i	185 (252)

DRUM BRAKE SPECIFICATIONS

Application	Wheel Cyl. Bore Diameter In. (mm)	Drum Diameter In. (mm)	Original Diameter In. (mm)	Maximum Refinish Diameter In. (mm)	Discard Diameter In. (mm)
Le Car	.866 (22)	7.10 (180)	7.10 (180)	7.136 (181)
18i	.866 (22)	8.996 (228.5)	8.996 (228.5)	9.035 (229.5)

DISC BRAKE SPECIFICATIONS

Application	Disc Diameter	Lateral Runout	Parallelism	Original Thickness	Minimum Refinish Thickness	Discard Thickness
Le Car	1.772 (45)	.004 (.10)395 (10)	⊙	.354 (9)
18i	1.890 (48)	.003 (.08)472 (12)354 (9)

⊙ — Rotor cannot be machined; it must be replaced.