

## MAZDA

**GLC  
626  
RX7  
B2000 Pickup**

### DESCRIPTION

Brake system is hydraulically operated using a tandem master cylinder and power brake unit. Front brakes are floating caliper disc. Rear brakes on most models are leading/trailing drums. Floating caliper rear disc brakes are available on RX7 as an option. On all models, a combination valve is used to prevent premature lockup of rear wheels.

### ADJUSTMENT

#### REAR DRUM BRAKE SHOES

**GLC (RWD)** - 1) Raise and support rear of vehicle. Release parking brake. Loosen the anchor pin lock nut and hold in position while turning anchor pin in proper direction until wheel is locked. See Fig. 1.

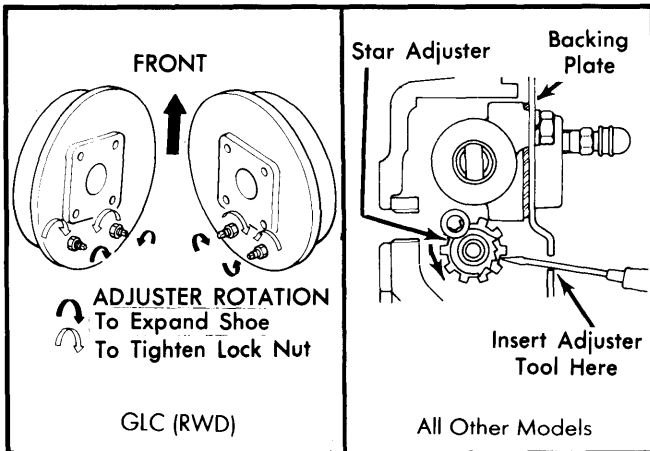

**Fig. 1 Rear Brake Shoe-to-Drum Adjustment**

2) Back off anchor pin until wheel just turns freely. Hold the anchor in position and tighten lock nut. Repeat the procedure for each shoe and ensure adjustment is equal on both wheels.

**All Other Models** - Raise and support rear of vehicle. Release parking brake. Remove adjusting hole plugs from backing plate. Using a brake adjusting tool, rotate star wheel adjuster (direction marked on backing plate) until wheel locks. Back off adjuster 3-4 notches, until wheel rotates freely. Install adjusting hole plugs.

#### PEDAL HEIGHT & FREE PLAY

1) Pedal height (measured from fire wall to pedal pad center) should be as shown in chart. To adjust, disconnect negative battery cable and stop light switch connector. Loosen stop light switch lock nut and turn switch until correct pedal height is obtained. Tighten lock nut and connect electrical leads.

2) Pedal free play should be .28-.35" (7-9 mm). To adjust, loosen push rod lock nut and turn push rod until correct free play is obtained. Tighten lock nut.

#### Brake Pedal Height Adjustment

Application	Height In. (mm)
GLC (FWD)	8.4-8.6 (210-220)
GLC (RWD)	
Man. Trans.	7.5-7.7 (190-195)
Auto. Trans.	7.7-7.9 (195-200)
626	7.2-8.2 (193-198)
RX7	7.5-7.7 (190-195)
B2000	8.1-8.3 (205-210)

#### STOP LIGHT SWITCH

Stop light switch is located under dash, above brake pedal. To adjust, disconnect battery ground cable and switch electrical lead. Turn switch until it contacts brake pedal arm. Check and adjust brake pedal height. Tighten lock nut and connect electrical connection and battery cable.

#### PARKING BRAKE

With service brakes properly adjusted, raise and support vehicle. On all models except B2000, remove parking brake lever boot and turn adjusting screw to lock rear wheels. Lever should be pulled 3-7 notches on GLC RWD, 5-9 notches on GLC FWD, 6-8 notches on RX7 and 5-7 notches on 626. Replace brake lever boot. On B2000, turn adjusting nut at equalizer (under vehicle) so rear wheels are locked when brake lever is pulled 5-10 notches. On all models, apply and release parking brake several times and make sure rear wheels rotate freely.

#### BRAKE WARNING LIGHT

**B2000** - Light indicates parking brake is engaged and warns of brake system malfunction. To adjust light operation with parking brake applied, bend switch plate down until light comes on when brake lever is pulled 1 notch and goes out when lever is released (ignition on). To check warning light operation, release parking brake and ensure light is off (ignition on). Open bleeder screw on wheel and depress brake pedal; light should glow. Close bleeder screw and replenish brake fluid in master cylinder reservoir. With ignition on, depress brake pedal firmly to center combination valve piston. Light should go off; turn ignition off.

**NOTE** - Brake warning light on B2000 will glow whenever any repairs are made to service brake system. Combination valve piston must be centered using this procedure.

**Except B2000** - Light indicates parking brake is engaged and also warns of low fluid level. Light should glow when parking brake lever is pulled 1 notch and go off when lever is fully released (ignition on). To check warning light operation, release parking brake lever and ensure light is off. Raise master cylinder reservoir cap and light should glow (ignition on). If not, check switch and wire connector.

### REMOVAL & INSTALLATION

#### FRONT DISC BRAKE PADS

**Removal** - Raise and support vehicle. Remove wheel and tire. Disconnect pad wear indicator (if equipped). Detach brake hose from shock absorber (if necessary). On RX7 and

## MAZDA (Cont.)

GLC FWD, remove lower caliper guide pin and pivot caliper body up out of way. On GLC RWD, 626 and B2000, remove spring clips and guide plates. Remove caliper body and hang from frame with wire. DO NOT disconnect hydraulic lines. On all models, remove anti-rattle springs (clips), pads and shims (if equipped).

**Installation** — To install, reverse removal procedure and note the following: Before mounting caliper, loosen bleed screw and seat piston. Tighten bleed screw. After pad installation, depress brake pedal several times to seat pads and bleed hydraulic system, if required.

**NOTE** — Grease pad mounting support, caliper contact area, and shims with special grease (NLGI No. 2 or equivalent).

### REAR DISC BRAKE PADS

**Removal** — Raise and support rear of vehicle. Remove wheel and tire. Disconnect parking brake cable from caliper. Remove lower caliper attaching bolt. Lift up lower side of caliper. Remove anti-rattle spring. Remove disc brake pads and shims.

**Installation** — Using brake piston wrench (49 FA18 602), turn piston clockwise until piston is inserted into caliper fully. Position piston so that dowel on pad will seat in piston stopper groove. To complete installation, reverse removal procedure.

### FRONT DISC BRAKE CALIPER

**Removal** — Raise and support vehicle. Remove wheel and tire. Disconnect and plug fluid line at caliper. On RX7, remove caliper guide pins and remove caliper. On all other models, remove spring clips and guide plates, then remove caliper. Remove disc pads as previously described and remove caliper mounting bracket.

**Installation** — To install, reverse removal procedure and bleed hydraulic system.

### REAR BRAKE CALIPER

**Removal** — Raise the rear of vehicle and support with safety stands. Remove tire and wheel. Disconnect parking brake cable from caliper. Disconnect brake hose. Remove caliper attaching bolt (lower side). Lift up caliper. Slide caliper toward inside of vehicle and remove caliper.

**Installation** — To install caliper reverse removal procedure and bleed hydraulic system.

### FRONT DISC BRAKE ROTOR

**Removal (Except GLC FWD)** — With caliper assembly removed, remove wheel hub grease cap, cotter pin, lock plate and ring adjusting lock nut. Remove thrust washer and outer bearing from hub, then slide hub and rotor assembly from spindle. On B2000, remove hub-to-rotor bolts and separate rotor from hub.

**Installation** — To install, reverse removal procedure and tighten hub-to-rotor bolts evenly (B2000). Adjust wheel bearings. See *Wheel Bearing Adjustment* in *SUSPENSION* Section.

**Removal (GLC FWD)** — 1) Raise and support front of vehicle. Remove wheel and tire. Raise lock nut tab. Apply

brakes to lock hub and remove drive shaft lock nut. Separate tie rod end from knuckle. Disconnect brake line from shock absorber.

2) Remove brake caliper assembly from knuckle and hang out of way. Remove ball joint and knuckle bolts and remove ball joint and knuckle from drive shafts as an assembly. Separate ball joints from knuckle. Remove wheel hub to rotor attaching bolts and using puller, remove rotor.

**Installation** — To install, reverse removal procedure.

### REAR DISC BRAKE ROTOR

**NOTE** — Removal and Installation procedures were not available.

### REAR BRAKE DRUM

**Removal (Except GLC FWD)** — Raise and support vehicle. Remove tire and wheel. Remove brake drum retaining screws and insert into tapped holes of brake drum. Turn screws evenly and force brake drum off flange.

**Removal (GLC FWD)** — Raise and support vehicle. Remove wheel and tire. Remove grease cap, nut and washer. Remove brake drum.

**NOTE** — If it is difficult to remove drum, widen the shoe clearance by removing the lever stop. If necessary, disconnect the parking brake cable from lever and move lever to touch backing plate.

**Installation (All Models)** — To install, reverse removal procedure. Tighten retaining screws evenly (if equipped). On GLC FWD, adjust wheel bearings. See *Wheel Bearing Adjustment* in *SUSPENSION* Section.

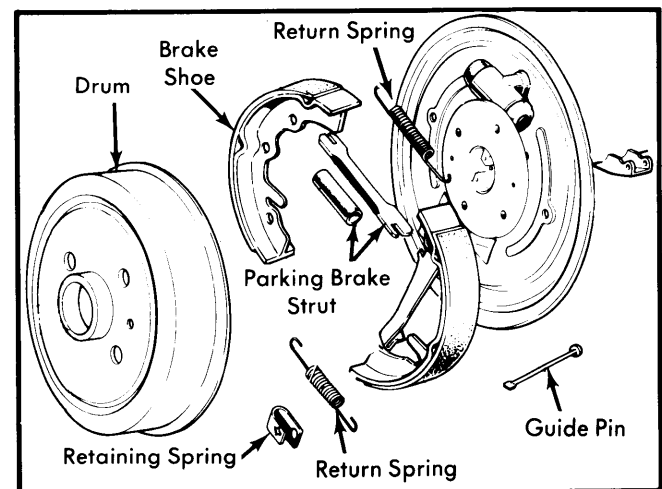

**Fig. 2 Disassembled View of GLC (RWD) Rear Brakes. Other Models Similar.**

### REAR BRAKE SHOES

**Removal (Except GLC FWD)** — With brake drum removed, remove brake shoe return springs, retaining springs and guide pins. Remove brake shoes. Remove parking brake strut and disconnect parking brake cable from operating lever of secondary shoe.

**Installation** — 1) Lubricate adjusting screw threads and contact surfaces of shoes and backing plate with brake grease. In-

## MAZDA (Cont.)

stall parking brake operating lever to secondary shoe and secure with clip. Engage lever in parking brake cable.

2) Position operating strut between slots of shoes. Mount assembly to backing plate so slots in shoes are toward adjusting screws. Install return springs and retainer springs.

**Removal (GLC FWD)** — Remove brake drum. Remove trailing shoe hold-down spring and pin. Remove trailing shoe assembly. Remove return spring, anti-rattle spring and leading shoe hold down spring and pin. Remove leading shoe assembly.

**Installation** — Install in reverse order of removal. Be careful to move quadrant until it touches backing plate. Grease contact areas of brake shoes and backing plate. Adjust wheel bearings. See *Wheel Bearing Adjustment in SUSPENSION Section*.

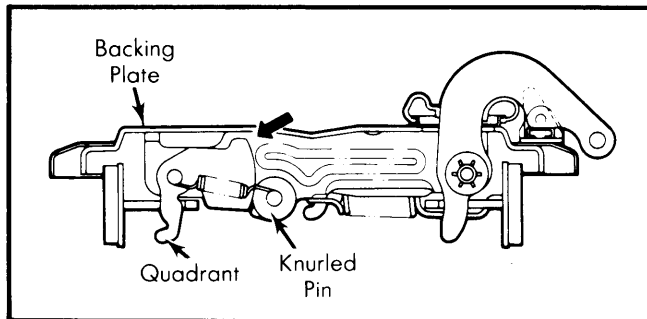

**Fig. 3 GLC FWD Brake Quadrant**

**NOTE** — To move the quadrant, insert a screwdriver between knurled pin and quadrant and twist in direction of arrow.

## MASTER CYLINDER

**Removal** — Disconnect oil level sensor coupler (if equipped). Disconnect hydraulic lines at master cylinder and plug to prevent entry of dirt and loss of fluid. Remove nuts attaching master cylinder to firewall or power brake unit and remove master cylinder from vehicle.

**Installation** — To install reverse removal procedure and bleed hydraulic system.

## POWER BRAKE UNIT

**Removal** — Disconnect hydraulic lines at master cylinder, and vacuum line at power brake unit. From inside vehicle, remove cotter pin and clevis pin retaining push rod to brake pedal, and separate. Remove nuts retaining power unit to firewall, then remove power brake unit and master cylinder as an assembly. Separate master cylinder from power brake unit.

**NOTE** — On GLC FWD and RX7, remove master cylinder from power brake unit before removing power brake unit.

**Installation** — To install, reverse removal procedure and bleed hydraulic system.

## OVERHAUL

## FRONT DISC BRAKE CALIPER

**Disassembly** — Thoroughly clean exterior of caliper and remove retainer and dust boot. Place a piece of wood in front

of piston, apply compressed air to fluid inlet and remove piston (tapping caliper with plastic hammer, if required). Remove piston seal without damaging caliper bore.

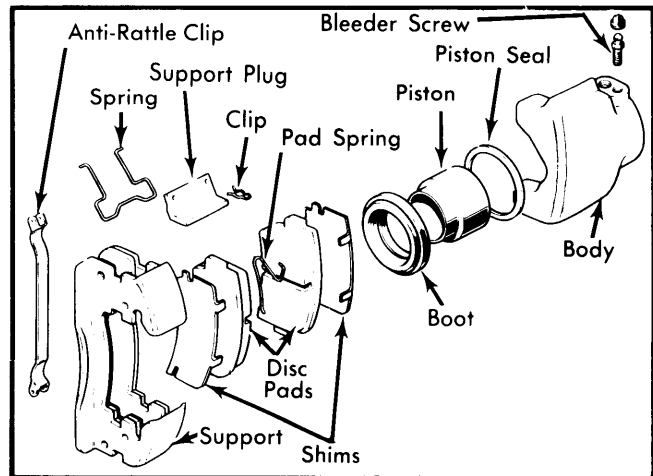

**Fig. 4 Exploded View of B2000 Front Disc Brake Caliper**

**Cleaning & Inspection** — Wash all parts in alcohol or brake fluid and air dry. Inspect cylinder bore and piston for scoring, scratches or rust. Replace defective parts. Minor damage may be removed with crocus cloth. Always replace dust boot and piston seal when caliper is disassembled.

**Reassembly** — Apply clean brake fluid to cylinder bore, piston and piston seal, then seat piston seal in caliper bore. Install piston carefully into cylinder bore and install dust boot and retainer.

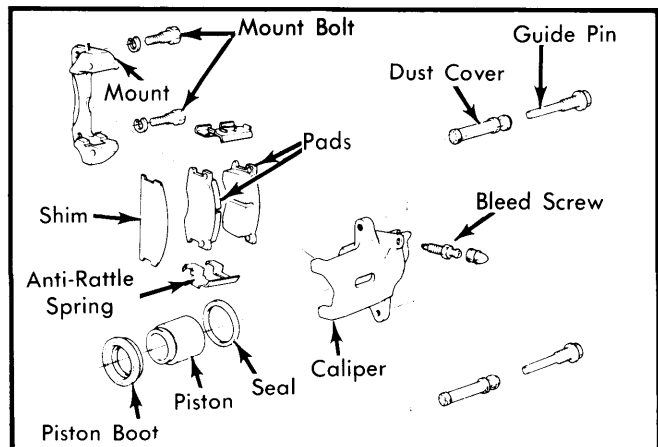

**Fig. 5 Exploded View of RX7 Front Brake Caliper. GLC & 626 Similar. Pads, Shims & Mounts May Differ.**

## REAR DISC BRAKE CALIPER

**Disassembly** — Remove dust boot retainer and boot. Turn piston counterclockwise with disc brake piston wrench (49 FA18 602) and screw out piston. Remove piston seal. Remove boot retainer. Slip off boot. Remove snap ring. Compress conical spring in caliper with spring compressor (49 FA18 601), valve spring lifter arm, (49 FA18 601) and removing plate (49 E301 144). Remove parking brake crank, torsion spring and strut. Remove adjusting bolt and conical spring assembly. Press out needle roller bearings.

## MAZDA (Cont.)

**Inspection** — Clean all parts in brake fluid or alcohol. Blow parts dry. Inspect caliper bore for scratches, scoring or rust. Minor damage can be eliminated by polishing with crocus cloth. Inspect needle roller bearing, strut, adjusting bolt and parking brake crank for corrosion, wear or damage. Check torsion spring and conical spring for corrosion, weakness and damage. Check piston and sleeve nut for excessive play. It should be within .012-.020" (.3-.5 mm).

**Reassembly** — 1) Assemble the caliper in the reverse order of disassembly. Use new piston seals and dust seals. Three kinds of grease contained in seal kit must be used. White grease is for caliper slide bolts and mounting bolts. Orange grease is for bearings, adjusting bolt, strut and piston boot. Pink grease is for piston seal.

2) Lubricate the piston and caliper bore with clean brake fluid. Press in needle roller bearing so that arrow on bearing faces outward. Assemble conical spring and adjusting bolt. See Fig. 6. Install adjusting bolt assembly, strut and torsion spring in the caliper. Install piston using disc brake wrench as described under Disc Brake Pad Installation.

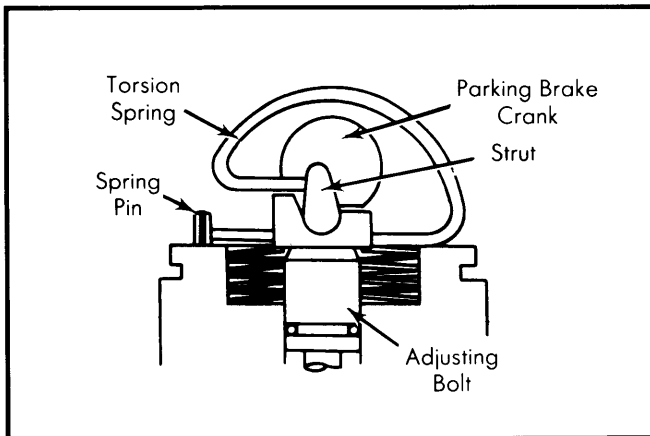
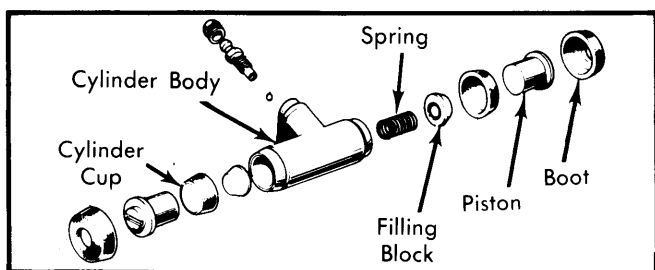

**Fig. 6 Proper Installation of Conical Spring and Adjusting Bolt**

### WHEEL CYLINDERS

**Disassembly** — Remove dust boots. Remove pistons with adjuster assemblies. Press on 1 cylinder cup to force out filling blocks and return spring.

**Cleaning & Inspection** — Clean all parts in alcohol or brake fluid. Check cylinder bore and pistons for scores, roughness or wear. Check clearance between cylinder bore and pistons; replace if clearance exceeds .006" (.15 mm). Check cups for deformation; replace as necessary.

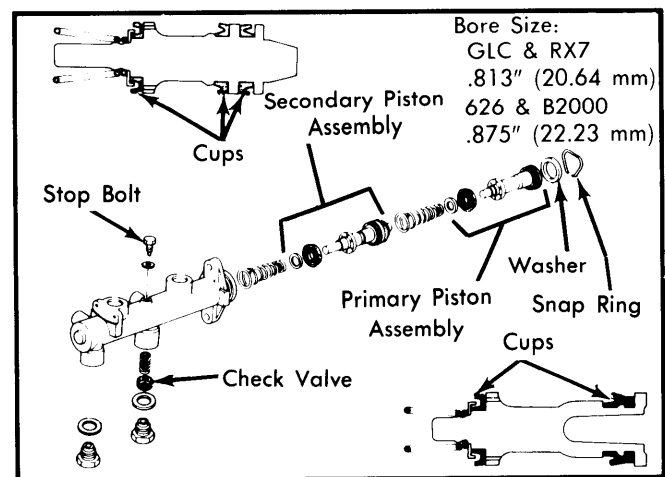

**Fig. 7 Exploded View Wheel Cylinder**

**Reassembly** — Reverse disassembly procedure and note the following: Coat all parts with clean brake fluid before reassembly. When installing cylinder cups, make sure flat side of cup faces outward.

### MASTER CYLINDER

**Disassembly** — Thoroughly clean outside of master cylinder and pour out any remaining brake fluid. If equipped, remove reservoir and dust boot. Depress primary piston assembly. Remove retaining ring from rear of cylinder bore, and remove washer, primary piston assembly and return spring. Depress secondary piston, remove stop bolt (if equipped) and insert guide pin to prevent damage to secondary piston cup. Carefully withdraw secondary piston assembly and return spring. Remove fittings, check valves and springs.



**Fig. 8 Exploded View of Typical Master Cylinder. Some Models May Vary Slightly.**

**Cleaning & Inspection** — Clean all parts in alcohol or brake fluid. Check all parts for scoring, roughness or wear. Check piston-to-cylinder clearance. If clearance exceeds .006" (.15 mm), replace parts as necessary. Remove all foreign matter from internal passages and recesses with compressed air. Check cylinder cups for deformation and replace as required.

**Reassembly** — Reverse disassembly procedure and note the following: Coat all parts with clean brake fluid before reassembly. Use new gaskets at all hydraulic unions. When assembled, make sure piston cups do not cover compensating ports. Make sure valve with hole in center faces front side outlet hole.

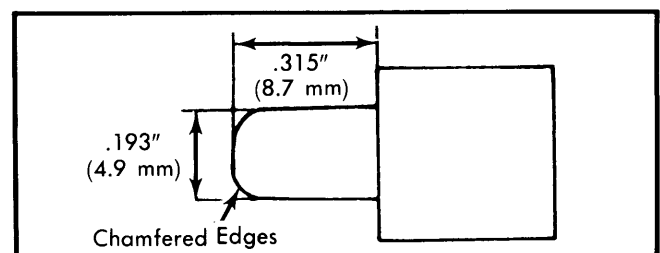

**Fig. 9 Dimensions for Fabricating Guide Pin**

# Brakes

## MAZDA (Cont.)

### POWER BRAKE UNIT

**NOTE** — Power brake units vary slightly between model application. The following overhaul procedures are general instructions which can be used if attention is paid to specific order of components.

**Disassembly** — 1) Remove master cylinder and check valve from power unit, then place power unit in a vise with push rod up. Scribe alignment marks on front and rear shells to assure reassembly in original position. Remove clevis, lock nut and dust boot from rear shell.

**CAUTION** — Separate front and rear shells carefully; spring tension may cause rear shell to release quickly.

2) Attach removal tool to rear shell mounting studs, then press down on tool while rotating clockwise to unlock rear shell. Lift rear shell assembly from power unit, then separate diaphragm and power piston assembly, valve rod and plunger assembly from rear shell. Remove return spring from power unit.

3) Remove diaphragm from power piston, then lift air silencer and filter from piston. Press in on valve rod and remove retainer key, then remove valve rod and plunger assembly. Press reaction disc from power piston. Remove push rod from front shell and if necessary, remove front seal.

**Cleaning & Inspection** — Clean all parts and blow dry with compressed air. Inspect all rubber parts for cuts, nicks, deterioration or other damage. Check power piston for cracks, distortion, chipping and damaged seats. Inspect front and rear shells for scratches, scores, pits, dents or other damage. Replace any defective parts.

**Reassembly** — Reverse disassembly procedure. Apply clean brake fluid to parts before reassembly. When assembling rear shell to front shell, make sure index marks are aligned. Before installing master cylinder to power unit,

measure clearance between primary piston and power unit push rod. Clearance on RX7 should be .004-.012" (.1-.3 mm). On all other models, clearance should be .004-.020" (.1-.5 mm). If clearance is not to specifications, correct by adjusting push rod length.

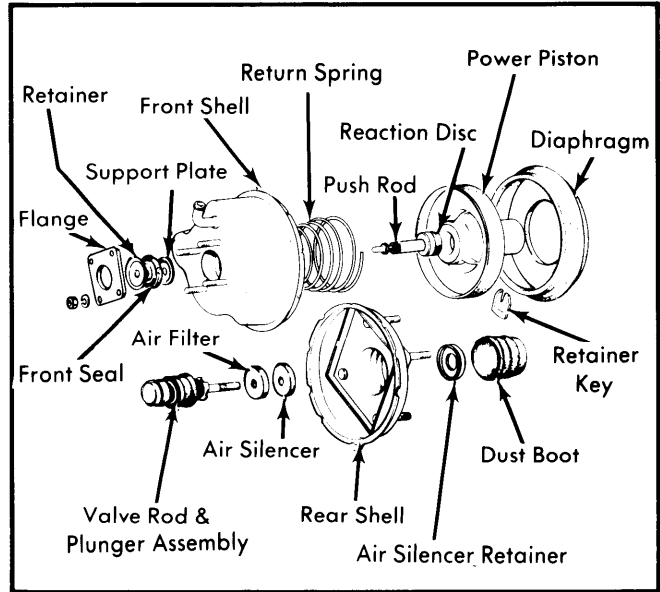

**Fig. 10 Exploded View of Typical Power Brake Unit**

### TIGHTENING SPECIFICATIONS

Application	Ft. Lbs. (N.m)
Caliper Mounting Bracket	
B2000 .....	40-47 (54-64)
GLC RWD .....	33-40 (45-54)
Caliper Guide Pin (626) .....	33-40 (45-54)

### DISC BRAKE SPECIFICATIONS

Application	Disc Diameter	Lateral Runout	Parallelism	Original Thickness	Minimum Refinish Thickness	Discard Thickness
GLC FWD	2.125 (54)	.004 (.10)	.....	.433 (11)	.394 (10)	.....
RWD	2.0 (51)	.0024 (.06)	.....	.512 (13)	.472 (12)	.....
626	2.125 (54)	.004 (.10)	.....	.512 (13)	.472 (12)	.....
B2000	2.125 (54)	.004 (.10)	.....	.472 (12)	.433 (11)	.....
RX7 Front	2.0 (51)	.004 (.10)	.....	.709 (18)	.669 (17)	.....
Rear	1.375 (35)	.004 (.10)	.....	.394 (10)	.354 (9)	.....

# Brakes

8-61

BRAKES

## MAZDA (Cont.)

DRUM BRAKE SPECIFICATIONS					
Application	Wheel Cyl. Bore Diameter In. (mm)	Drum Diameter In. (mm)	Original Diameter In. (mm)	Maximum Refinish Diameter In. (mm)	Discard Diameter In. (mm)
GLC FWD	.688 (17.5)	7.09 (180)	7.09 (180)	7.13 (181)	.....
RWD	.750 (19)	7.87 (200)	7.87 (200)	7.91 (201)	.....
626	.813 (20.6)	9.00 (229)	9.00 (229)	9.04 (230)	.....
B2000	.875 (22)	10.24 (260)	10.24 (260)	10.28 (261)	.....
RX7	.750 (19)	7.87 (200)	7.87 (200)	7.91 (201)	.....