

MERCEDES-BENZ POWER-ASSISTED RECIRCULATING BALL

240D
280 Series
300 Series
380 Series

DESCRIPTION

Power steering system is composed of power steering pump, steering gear and connecting hoses. All pumps have integral reservoirs. Both ZF and VT49 type pumps are used; some of these pumps are made of a light alloy material. The light alloy pumps are interchangeable with the cast iron type.

All power steering pumps are engine driven vane type with a control valve. The purpose of the power steering gear pump is to supply fluid (under pressure) to the steering gear.

Steering gear has integral piston/steering nut. Fluid pressure to each side of piston/steering nut is controlled by a control valve which is moved by a lever from steering column shaft. Steering system has a digressive action. Boost is relatively weak in the central range, and increases as steering resistance increases.

LUBRICATION

Capacity – 2.6 pts. automatic transmission fluid.

REMOVAL & INSTALLATION

POWER STEERING PUMP

Removal – 1) Remove power steering tank cover, spring and damping plate. Drain tank with a syringe. Disconnect and plug high pressure and return hoses.

2) Loosen fastening bolts and push pump towards engine, remove "V" belts from pulley. Remove remaining bolts and remove pressure pump with carrier.

Installation – To install power steering pump, reverse removal procedures. Fill system with recommended fluid.

POWER STEERING GEAR

NOTE – All models are equipped with a modified power steering gear. The stop for the full lock position is incorporated into the housing itself, not on the steering arms as before. When replacing steering gears, install only the newer type gear. This gear can be recognized by an "A" * stamped on the housing.

Removal — 1) Drain fluid from power steering pump. Disconnect and plug pressure line and return line from steering gear. Remove bolts from steering coupling. Remove rear exhaust system and left hand exhaust pipe at manifold (all 380 models). Disconnect center link and tie rod from pitman arm. Remove bolts securing steering gear to frame. Force steering gear from steering column shaft, in a downward direction.

2) Drain fluid from steering gear, remove steering coupling and pitman arm from gear (be sure to mark pitman shaft-to-pitman arm position for proper assembly).

Installation – To install steering gear, reverse removal procedure. Replace locking nuts and bolts, tighten to specifications. Fill system with recommended fluid.

OVERHAUL

POWER STEERING PUMP

Disassembly (VT49 Pump) – 1) Remove wing nut and cover from reservoir. Remove compression spring, 2 damping plates and filter ring. Remove Woodruff key from input shaft.

2) Install puller 1104-7251 on input shaft. Screw bolt back on puller enough to install clamping shoes 11004-6304 between puller and seal. Turn clamping cone of puller to the right up to stop and remove seal ring out of housing.

3) On rear of housing, push in cover and insert a punch through hole in housing. See Fig. 1. Push in on punch and remove circlip and cover. Remove spring and "O" ring from housing. Push input shaft with pressure plate at cover end, rotor, cam ring and pressure plate at input end out of housing in rearward direction.

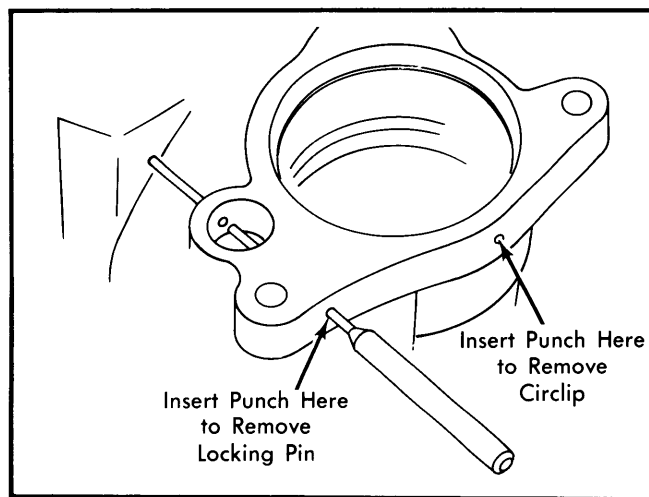

Fig. 1 Circlip Punch Hole Location and Removing Locking Pin on VT49 Pump

4) Remove pressure plate, cam ring and blades. Remove locking clip from input shaft, then remove rotor and pressure plate. Remove cylinder pins from housing. Using a punch, knock out locking pins in housing. See Fig. 1.

5) Remove closing plug, volume control valve and compression spring from housing. Clamp volume control valve in vise and disassemble valve. Check spacer washer, valve cone and compression spring.

Inspection – Check pressure plates, input shaft, and bearing bushing for wear. Check blades for easy sliding in rotor. Check surfaces of volume control valve and bore in pump housing for wear or damage.

NOTE – Never replace volume control valve only, replace power steering pump.

Reassembly – To install power steering pump, reverse removal procedure. Fill system with recommended fluid.

Disassembly (ZF Pump) – 1) Remove Woodruff key from input shaft. Install puller (1104-7251) on shaft. Screw bolt back on puller enough to install clamping shoes (1104-6304) between puller and seal.

MERCEDES-BENZ POWER-ASSISTED RECIRCULATING BALL (Cont.)

2) Turn clamping core of puller to the right up to stop, remove tool, seal and washer from housing. Remove knurled nut and cover from housing. Remove retaining and compression springs. Remove upper damping plate, filter ring, and lower damping plate.

3) On rear of housing, push in cover plate and using a screwdriver remove circlip and cover. Remove "O" ring, compression spring, and pressure plate. Remove rotor with blades from input shaft and "O" ring and cam ring.

4) Remove lock ring from forward end of shaft. Press out input shaft from rear of housing. Remove circlip from shaft and remove bearing by pressing off toward rear of shaft. Remove needle bearing from housing.

5) Remove closing plug from housing. Remove compression spring and volume control valve. Clamp volume control valve in vise, disassemble and check spacer washers, ball, and compression spring.

Inspection — Check pressure plates, input shaft, bearing housing, and bushing for wear. Check blades for easy sliding in rotor. Check surfaces of volume control valve and bore in pump housing for wear or damage.

NOTE — Never replace volume control valve only, replace power steering pump.

Reassembly — To install power steering pump, reverse removal procedure. Fill system with recommended fluid.

POWER STEERING GEAR

Disassembly — 1) Attach steering gear to a suitable assembly plate (116 589 01 59 00). Remove lock nut from adjusting screw and remove copper seal ring. Remove bolts attaching pitman shaft cover to steering case.

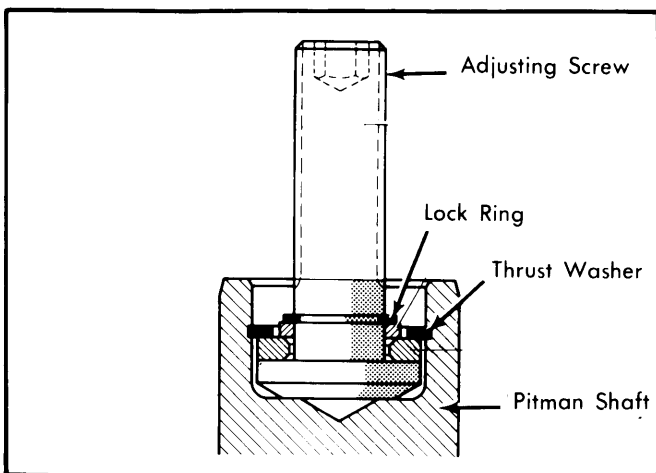

Fig. 2 Sectional View of Adjusting Screw

2) With steering in center position, turn adjusting screw clockwise. This forces pitman shaft, with housing, from steering gear case. Remove pitman shaft with cover. Remove "O" rings from cover. Remove lock ring and seal ring. Remove lock ring from pitman shaft and remove adjusting screw with thrust washers See Fig. 2.

3) Remove bolts securing bearing cap to steering gear case. Turn worm gear counterclockwise until bearing cap is forced out of steering gear case.

NOTE — Balls will fall out of ball guide if worm gear is turned too far.

4) Remove bearing cap and worm gear with piston/steering nut from steering gear case.

5) Unscrew worm gear with bearing cap from piston/steering nut.

CAUTION — Do not lose circulator balls.

6) Remove "O" ring from bearing cap and attach bearing cap to a suitable assembly fixture.

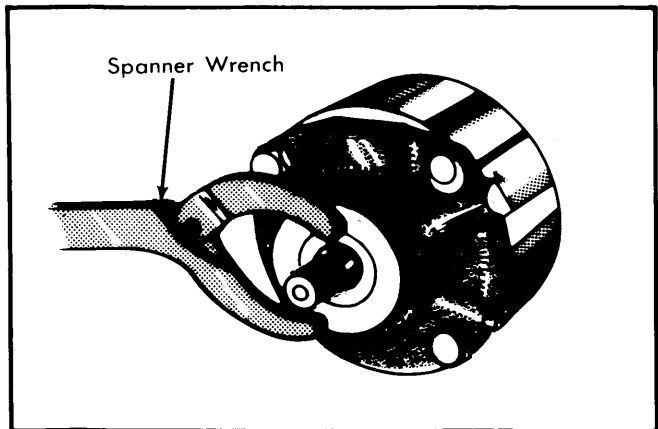

Fig. 3 Removing Bearing Insert from Bearing Cap

7) Unscrew slotted nut, using hook wrench, from bearing insert.

8) Remove bearing insert from bearing cap using spanner wrench. See Fig. 3. Remove steering worm and washer from bearing cap. Remove roller cage from steering worm, along with seal and "O" rings.

9) Remove bearing and disc from bearing cap. Remove bolts, clamp, and both ball guide halves from piston/steering nut.

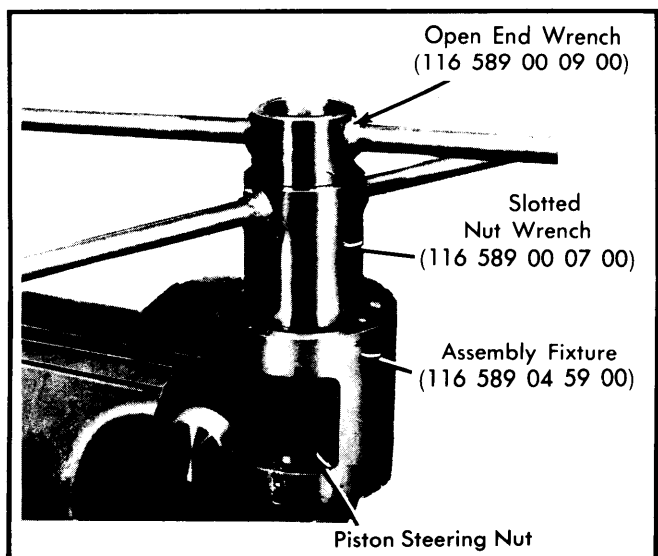

Fig. 4 Removing Worm Gear Nut from Piston Steering Nut

MERCEDES-BENZ POWER-ASSISTED RECIRCULATING BALL (Cont.)

10) Using suitable clamp and tools, remove worm gear nut from piston/steering nut. See Fig. 4. Remove seal ring and "O" ring from worm gear nut.

11) Remove bearings from piston/steering nut, then remove lock ring, cover and control valve from steering gear case. See Fig. 5.

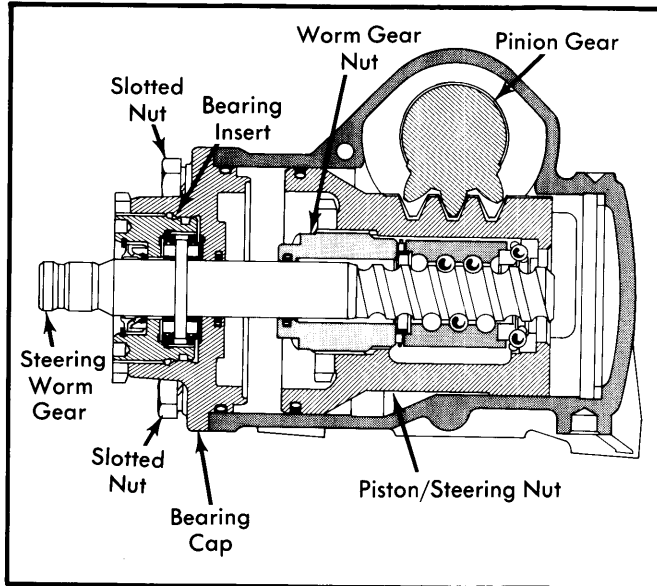

Fig. 5 Cross Sectional View of Steering Gear

Inspection - 1) On worm gear, check ball paths and bearings surfaces for wear and damage, replace if necessary.

2) On piston/steering nut, remove seal rings, "O" rings, bearings and races, and worm gear nut. Inspect for wear or damage and replace as necessary.

3) Check pitman shaft for wear or damage on bearing surfaces, check for bent or warped shaft and replace as necessary. Check steering case, cover, and bearing insert for wear or damage and replace as necessary.

4) On control valve, check reaction piston in control valve for free movement. If necessary remove pistons from control valve by removing lock rings.

Reassembly - To reassemble steering gear, reverse disassembly procedure. Replace all "O" rings and sealing rings with new ones. Adjust gear to specifications.

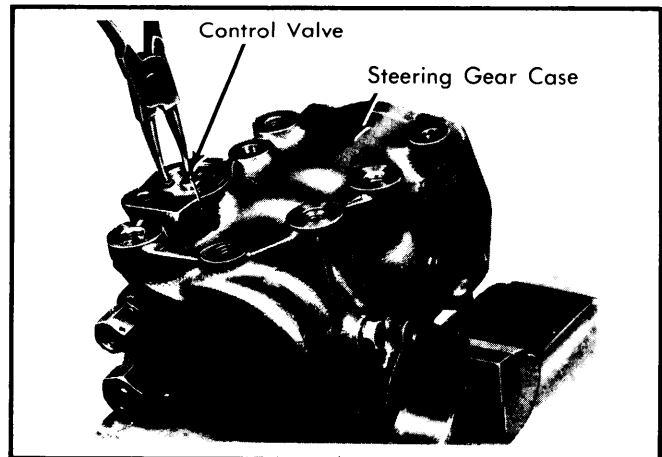

Fig. 6 Removing Control Valve from Steering Gear Case

STEERING SPECIFICATIONS

Application

Dimensions

Steering Wheel Free Play	1" (25 mm) Maximum
Pump Circulation Pressure ...	28.4-71.0 psi (2.0-5.0 kg/cm ²)
Number of Balls in Ball Circuit	24
End Play of Pump Shaft	
New028" (.71 mm) Maximum
Used039" (.99 mm) Maximum

TIGHTENING SPECIFICATIONS

Application

Ft. Lbs. (N.m)

Steering Gear-to-Frame	50-57 (68-78)
Pitman Arm-to-Pitman Shaft	116-145 (158-197)
Slotted Nut-to-Bearing Cap	101-115 (137-156)
Adjusting Screw Nut	22-25 (30-34)
Pump Housing Bolts	25-29 (30-39)