

CHRYSLER CORP. IMPORTS POWER-ASSISTED RECIRCULATING BALL

Arrow Pickup
Challenger
Ram-50 Pickup
Sapporo

DESCRIPTION

POWER STEERING GEAR BOX

The power steering gear box displaces fluid to provide hydraulic pressure assist when turning. A torsion bar transmits road feel to the driver. A one piece rack-piston nut is geared to the sector shaft. An adjusting screw on the shaft maintains backlash between the shaft and the rack-piston.

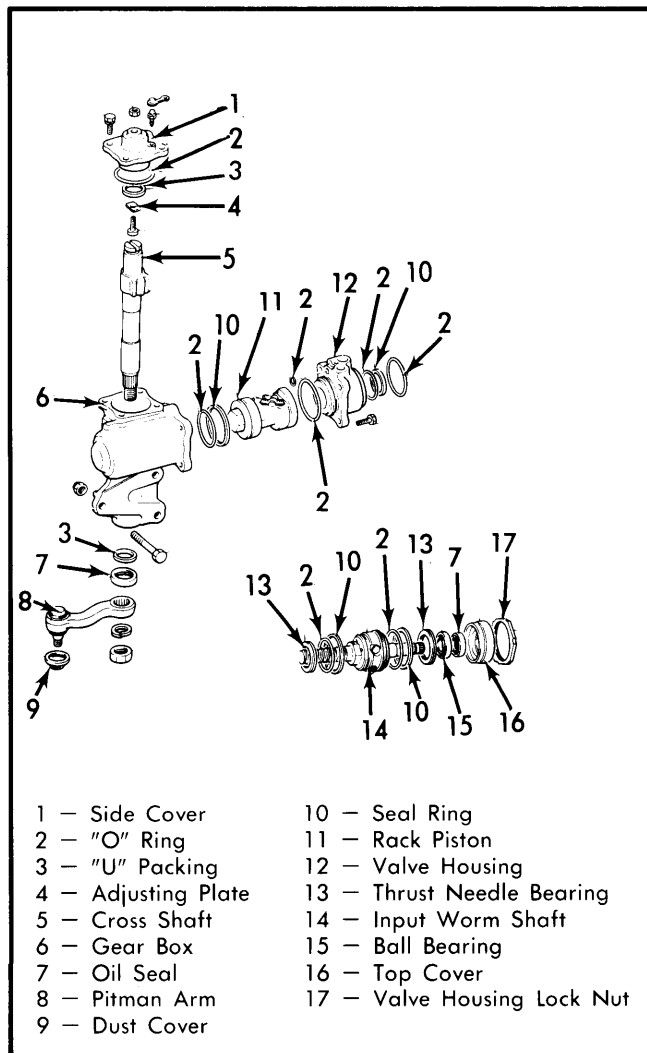

Fig. 1 Exploded View of Chrysler Corp. Power Steering Gear

POWER STEERING PUMP

Chrysler Corp. uses 2 different types of pumps depending on model. Arrow and Ram-50 use a type "A" pump with retaining ring holding pump end plate to body. Pump has a separate reservoir. Challenger and Sapporo use a type "B" pump with oval fill neck. Pulley is held to drive shaft with bolts.

LUBRICATION

Capacity - 2.2 pints.

Type - ATF Dexron II

ADJUSTMENT

BELT TENSION ADJUSTMENT

With 22 lbs. (10 kg) applied to belt, deflection at center should be .28-.37" (7-10 mm).

STEERING WHEEL PLAY

Raise front of vehicle. Start engine and idle at 1000 RPM. With steering wheel in center position check that free play is within 1" (25 mm). If necessary, adjustment can be made at the steering gear housing adjusting bolt.

FLUID REPLACEMENT

1) Disconnect suction hose at reservoir and drain fluid. Disconnect pressure hose at pump and drain fluid. Disconnect coil high tension wire.

2) Raise and support vehicle. Turn steering wheel lock to lock several times while cranking engine to drain fluid from gear box. Reconnect all hoses and fill power steering system with fluid. Bleed system.

NOTE - Do not crank engine for more than 15 seconds.

AIR BLEEDING

NOTE - Make sure reservoir is filled before bleeding. Add fluid as needed during bleeding.

1) Raise and support front of vehicle. Disconnect coil high tension wire. Turn steering wheel lock to lock, 5 or 6 times, while cranking engine.

2) Lower vehicle and install a 20" (500 mm) hose to bleeder screw of gear box. Place other end of hose in a container. Connect coil wire.

3) Start engine and idle. Turn steering wheel to left lock and loosen bleeder screw. Repeat this until no more bubbles appear in container (from hose). Remove hose and tighten bleeder screw. Check fluid level, add fluid if necessary. Turn steering wheel lock to lock and note that fluid level in reservoir does not change more than .12-.16" (3-4 mm).

NOTE - Do not crank engine for more than 15 seconds.

CAUTION - Abrupt rising of fluid level after engine is shut off signals incomplete bleeding. Repeat procedure as needed.

FLUID PRESSURE TESTING

1) Remove pressure hose from oil pump and attach adapter for pressure gauge (C3309E). Tighten to 22-29 ft. lbs. (30-39

CHRYSLER CORP. IMPORTS POWER-ASSISTED RECIRCULATING BALL (Cont.)

N.m). Start engine and place thermometer in reservoir. Close the gauge valve fully 3 times to bleed air from gauge. Check fluid level and add if necessary.

2) When oil temperature reaches 170°F (76.6°C) for type "A" pumps, or 122°F (50°C) for type "B" pumps, check pressure. With valve closed, type "A" pumps should read 1066-1210 psi (75-85 kg/cm²). Type "B" pumps should have a pressure of 925-1066 psi (65-75 kg/cm²).

3) Valve open pressure for both types of pumps should be 142 psi (10 kg/cm²). Reinstall pressure hose, taking care not to twist hose or interfere with adjacent parts.

CAUTION — Do not keep shut-off valve closed more than 3 seconds at a time. Do not keep steering wheel turned more than 10 seconds at a time.

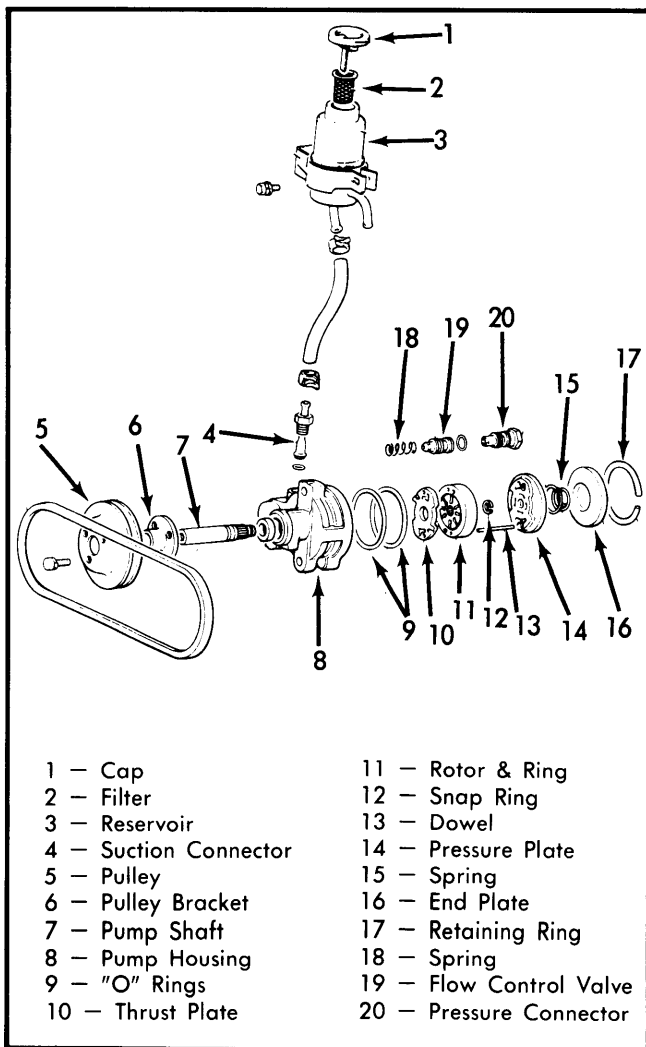

Fig. 2 Exploded View of Power Steering Pump (Type "A", Arrow and Ram-50)

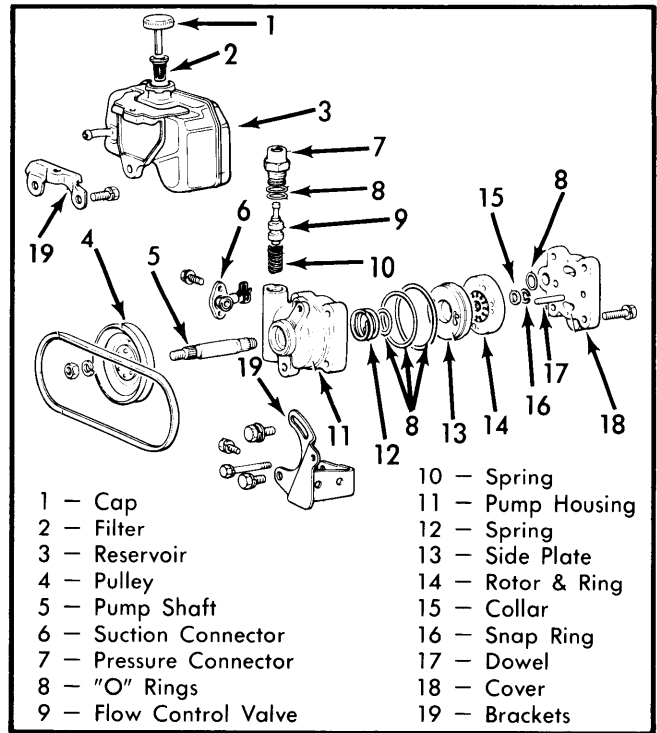

Fig. 3 Exploded View of Power Steering Pump (Type "B", Challenger and Sapporo)

REMOVAL & INSTALLATION

POWER STEERING GEAR BOX

Removal — 1) Disconnect steering shaft from gear box. Disconnect tie rod from relay rod and the pitman arm from relay rod. On pickup models, remove air cleaner and under cover. On all models, disconnect pressure and suction hoses from gear box.

2) Loosen gear box mounting bolts. On pickup models with automatic transmission, remove throttle linkage and shield. On pickup models with manual transmission, remove starter from transmission. On all models, remove gear box. Remove pitman arm from gear box.

Installation — Install in reverse of removal procedures, noting the following: When connecting cross shaft to pitman arm, align slit of cross shaft tip to marking of pitman arm. Insure that clearance between bolt hole at bottom of gear box and pitman arm is within tolerance. Standard value is .77" (19.6 mm).

POWER STEERING OIL PUMP

Removal — On power steering pump type "B", loosen pulley nut before removing belt. On all pumps, remove pulley and belt. Disconnect pressure and suction hoses and cap openings. Remove oil pump attaching bolts and remove pump.

Installation — Install in reverse of removal procedures, noting the following: Check oil pump bracket for slack and tighten if

CHRYSLER CORP. IMPORTS POWER-ASSISTED RECIRCULATING BALL (Cont.)

necessary. Start engine after reinstallation and run at 2000 RPM for 5 minutes to check for fluid leaks.

OVERHAUL

POWER STEERING GEAR BOX

Disassembly – 1) Loosen adjusting lock nut and remove. Remove side cover bolts and screw in the adjusting bolt 2 or 3 turns. With gear in neutral position, tap bottom of cross shaft with plastic hammer and remove.

2) Remove valve housing locknut with spanner (MB990852 or equivalent).

3) Place valve housing in vise and move rack-piston up and down to check backlash between circulator balls and rack-piston gutter. Turn the rack-piston fully into the valve housing and then loosen 2 turns to measure backlash. Service limit is .008" (.2 mm). If backlash exceeds limit, replace ball screw unit and rack-piston as an assembly.

4) Remove rack-piston by turning counterclockwise. Do not lose circulator balls. Remove "O" ring, seal ring, steel ball, circulator and circulator holder from rack piston. Do not disconnect end cap. Remove thrust plate, needle roller bearings, seal rings and "O" rings from input worm unit and valve housing.

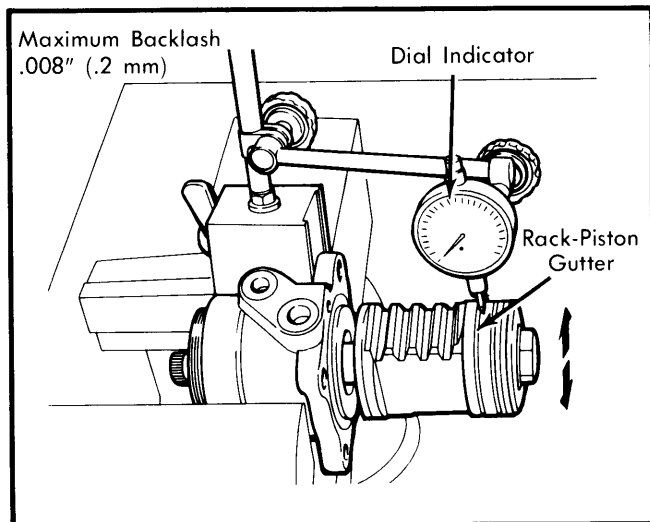

Fig. 4 Measuring Backlash of Gutter and Ball.
Service Limit .008" (.2 mm)

5) Screw in adjuster bolt at tip of cross shaft and remove side cover. Remove "O" ring, bearing and adjusting plate. Do not remove bleeder plug unless necessary. Remove seal ring and "O" ring from valve housing. Remove bearing and oil seal from top cover. Remove oil seal and seal ring from gear box.

NOTE – Replace all "O" rings, seal rings and oil seals once they have been removed. When replacing, lubricate with power steering fluid before insertion.

Inspection – 1) Inspect cross shaft bearing surface for peeling or pitting. Check stepped wear of adjusting bolt shank. Inspect for damage to gear teeth on cross shaft and rack-piston.

2) Inspect for uneven wear of circulator rolling surface on rack-piston. Check for damage to balls. Inspect for peeling or pitting on thrust needle roller bearing, and bearing surface of thrust plate on worm unit. Check ball rolling surface of worm shaft for peeling and sealing surface of input shaft for damage. If thrust bearing or thrust plate is defective, replace both as a set.

3) Inspect valve housing for damage to seal ring-to-housing contact surface. Inspect "O" ring sealing surface of seal housing, valve housing and side cover.

Reassembly – 1) Lubricate bearing surface of side cover and install needle roller bearings. Apply grease to bottom of side cover. Install "O" ring to side cover. Insert adjusting bolt and plate into "T" slot on top of cross shaft, and set play with adjusting shims. Cross shaft play is 0-.002" (0-0.5 mm).

2) When installing adjusting shims, place chamfered edge of adjusting plate to contact surface of cross shaft. See Fig. 5. Align cross shaft with side cover and tighten with adjusting bolt. Tighten lock nut temporarily. Apply grease to oil seal lip and press in oil seal and ball bearing to top cover.

3) Apply grease to "U" packing and lip of oil seal and press in to gear box. Install "O" ring and seal ring to input worm shaft. Install thrust plates and needle bearings in input worm units. Install top cover side thrust plate with smaller outside diameter first.

4) Install "O" ring and seal ring (compressed into heart shape) into valve housing. Install input worm shaft to the valve housing. Install thrust plate, needle roller bearing and thrust plate in that order to top cover.

NOTE – Install thinner thrust plate to top cover side.

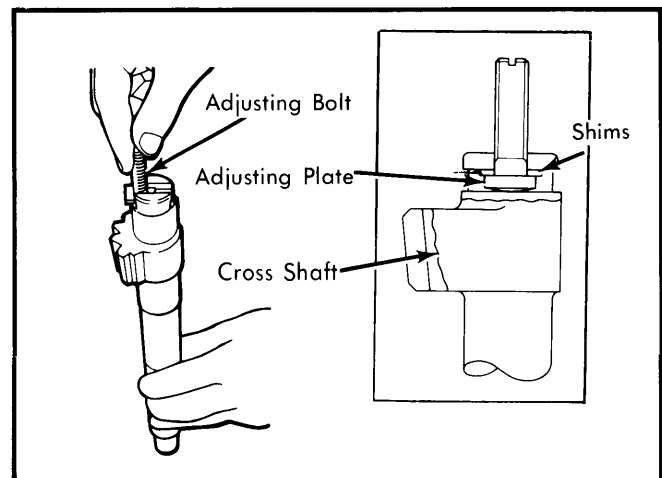

Fig. 5 Adjusting the Cross Shaft "T" Slot.
Place Chamfered Edge of Adjusting Plate to Contact Surface of Cross Shaft.

CHRYSLER CORP. IMPORTS POWER-ASSISTED RECIRCULATING BALL (Cont.)

5) Tighten top cover to the valve housing using pin tool (MB990853 or equivalent). Check worm shaft for uniform rotation. Tighten valve housing lock nut with spanner (MB990852 or equivalent). Take care not to allow top cover to rotate.

NOTE — Final tighten valve housing lock nut at time of measurement of total starting torque.

6) Measure starting torque using preload socket (CT-1108 or equivalent). Preload should be 2.2-5.6 INCH lbs. Adjust, if necessary, by loosening valve housing nut and retightening. Install "O" ring and seal ring to rack piston.

7) Insert rack-piston into input worm shaft until piston touches worm shaft end. Rotate worm shaft and align ball running surface with ball insertion hole. Insert 19 balls into hole by pushing lightly with a brass rod. See Fig. 6.

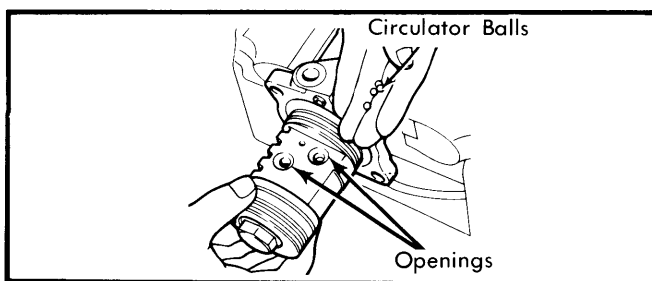

Fig. 6 Installing Circulator Balls to Rack Piston. Install Balls Using a Brass Rod to Push In.

8) Measure distance from rack-piston to balls. If distance is more than .5" (13 mm), a ball is in wrong groove. Remove and reinstall balls correctly. Insert 7 more balls with grease to prevent them from falling. Insert circulator and holder to rack piston attaching place and tighten.

9) Hold gear box in a vise. Apply a thin coating of automatic transmission fluid to teeth and shaft of rack piston. Apply grease to oil seal lip. Install ball screw unit. Tighten valve housing. Do not allow cover to rotate.

10) Wrap serration of cross shaft with vinyl tape to avoid damage when installing. Install cross shaft and side cover to gear box. Tighten side cover. Measure starting torque of input worm shaft using preload socket (CT-1108 or equivalent). Adjust to 4.3-7.8 INCH lbs.

11) Make sure ball screw unit operates smoothly. Tighten valve housing lock nut with spanner (MB990852 or equivalent). Check preload. Connect cross shaft with Pitman arm.

NOTE — When connecting cross shaft with Pitman arm, align slit of cross shaft tip to marking on Pitman arm. Clearance between bolt hole center in gear box and Pitman arm should be .77" (19.5 mm).

POWER STEERING PUMP

Disassembly (Pump Type "A") — 1) Remove pulley bracket with puller then remove suction connector. Remove pressure connector. Remove retaining ring using small punch inserted in

hole of pump housing, opposite flow control valve hole, and then pry out ring with screwdriver.

2) Remove end plate and "O" ring. Remove flow control valve and spring. Tap on pump shaft with plastic hammer just enough to loosen pressure plate. Remove pressure plate, pump shaft, ring, vanes and rotor.

3) Remove pump shaft retaining ring and discard. Remove rotor and thrust plate from drive shaft. Remove dowel pins from housing. Pry pump shaft seal out of housing.

Inspection — Check flow control valve, rotor and ring, end plates and pump shaft for damage, scoring or excessive wear. Inspect pump housing for cracks or signs of visual damage. Check "O" ring seats for scratches or burrs. Inspect pump shaft bushing, in pump housing. If bushing is damaged, replace pump housing. Replace any parts necessary. If any internal pump parts are found to be damaged, flush steering gear or disassemble and clean gear.

NOTE — Lubricate "O" rings and all internal pump components with ATF Dexron II fluid before reassembly.

Reassembly — 1) Install new pump shaft seal in pump housing. Install new pressure plate "O" ring to 3rd groove from end of pump housing. Insert both dowel pins into pump housing. Install thrust plate and rotor to pump shaft, then install new snap ring to pump shaft. Make sure rotor is installed with countersunk side toward thrust plate.

2) Install pump shaft into pump housing, making sure thrust plate slides over dowel pins properly. Install ring into pump housing, over dowel pins and with arrow (on ring) toward rear of pump housing. Install vanes in rotor and make sure rounded edge of vanes face outward.

3) Install pressure plate into pump housing and over dowel pins. Make sure circular depression (for spring) is toward rear of housing. Install new "O" ring in 2nd groove from rear of pump housing. Place spring on pressure plate, then install end plate to pump housing. Depress end plate just enough to install retaining ring. Make sure retaining ring seats properly.

NOTE — Pressure plate must be pressed .06" (1.6 mm) over "O" ring to seat.

Disassembly (Pump Type "B") — 1) Drain fluid. Remove suction plate bolts. Remove reservoir from pump. Hold pump in a vise. Remove pump cover bolts and cover. Tap the shaft with a plastic hammer. Take out the cam ring, vanes, shaft assembly, side plate spring and "O" rings.

2) Remove snap ring from shaft assembly using snap ring pliers. Remove collar, rotor and side plate from shaft. Pry out oil seal from pump body with a screwdriver. Remove connector and take out control valve, flow control spring and "O" rings.

Inspection — 1) Measure clearance between shaft and pump body. If clearance is more than .0035" (.09 mm), replace pump body as an assembly. Inspect pump shaft oil seal lip and bushing end for damage. Inspect groove of rotor vane and cam surface for stepped wear.

CHRYSLER CORP. IMPORTS POWER-ASSISTED RECIRCULATING BALL (Cont.)

2) Check vane for damage and ring and rotor sides for grooving. Replace entire assembly if any damage is seen. Inspect side plate spring. Minimum length should be .67" (17 mm). Check flow control spring. Minimum length should be 1.95" (49.5 mm). Check sliding surfaces of control valve for obstructions.

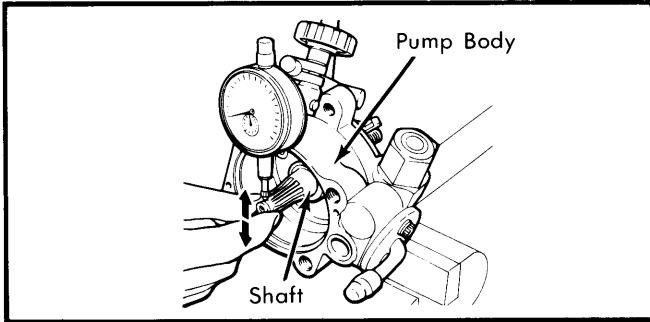

Fig. 7 Measuring Clearance Between Shaft and Pump Body. Service Limit. 0035" (.09 mm).

NOTE — Lubricate "O" rings and all internal pump components with ATF Dexron II before reassembly.

3) Install cam ring. Smaller diameter bore faces side plate. Install cover and oil reservoir bracket to pump body and tighten.

Remove reservoir bolt and install reservoir. Tighten suction plate.

Reassembly — 1) Install flow control valve and spring to pump body. Depress control valve to check for smooth operation. Apply grease to lip of oil seal. Press seal into pump body. Install side plate, rotor and collar to shaft.

2) Tighten pulley nut temporarily. Hold snap ring on shaft using snap ring pliers. Install "O" ring and side plate spring to pump body. Install vanes onto rotor. Insert shaft assembly with vanes to pump body.

TIGHTENING SPECIFICATIONS

Application	Ft. Lbs. (N·m)
Gear-to-Frame	40-47 (54-64)
Oil Pump Cover	22-29 (30-39)
Pitman Arm-to-Cross Shaft	94-109 (128-148)
Pressure Hose	22-29 (30-39)
Suction Hose	29-36 (39-49)
Side Cover	33-41 (45-46)
Valve Housing	33-41 (45-46)
Valve Housing Nut	130-166 (178-226)
	INCH Lbs. (N·m)
Circulation Holder	30-40 (3.4-4.4)
Gear Box Top Cover	8.6-12.1 (1.0-1.4)