

## TOYOTA (EXC. LAND CRUISER) RECIRCULATING BALL

Celica  
Corolla  
Corona  
Cressida  
Pickup

### DESCRIPTION

#### STEERING GEAR

Steering gear is a variable ratio, recirculating ball type. Ball bearings circulate within grooves in worm and nut. As worm shaft turns, ball nut moves up or down, turning the sector shaft and pitman arm.

#### STEERING LINKAGE

Linkage consists of an idler arm, center relay rod, adjustable tie rods, and steering knuckles. Pickups also use a steering damper attached to center relay rod. The connection between each component is by ball joints. Linkage assembly is connected to steering gear by a pitman arm.

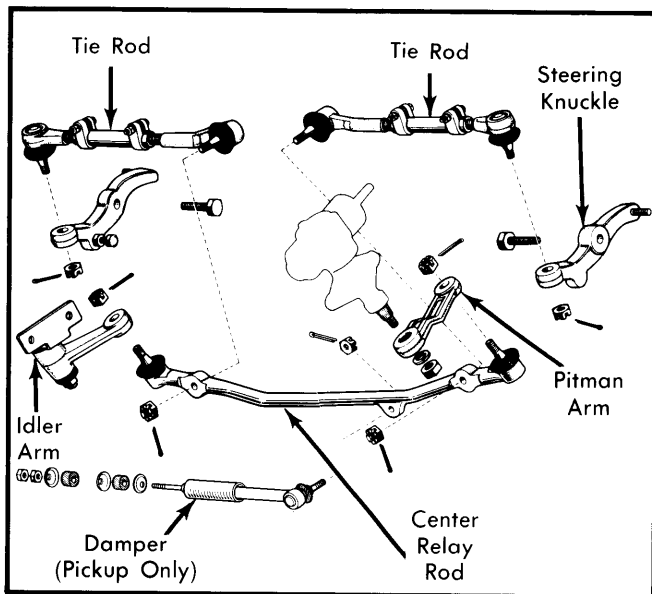

**Fig. 1 Exploded View of Toyota Steering Linkage (Except Pickup 4-WD Models)**

### ADJUSTMENT

See *Overhaul* procedures in this article.

### REMOVAL & INSTALLATION

#### STEERING GEAR

**Removal** — Mark steering gear shaft at flexible coupling or universal joint. Mark steering gear shaft at pitman arm. Disconnect pitman arm from steering gear. Remove steering gear bolts from frame and disconnect steering gear from steering shaft as gear is removed.

**Installation** — To install steering gear, reverse removal procedures and note the following: Make sure marks made upon removal are aligned upon installation.

#### STEERING LINKAGE

**Removal** — 1) On all models except Pickup 4-WD, mark pitman arm at sector shaft. Use a suitable puller to disconnect the following components: Pitman arm from sector shaft, and tie rod ball joints from steering knuckles. On Pickup 2-WD models, disconnect steering damper from crossmember. Remove idler arm bracket bolts, then remove steering linkage assembly from vehicle.

2) On Pickup 4-WD models, mark pitman arm at sector shaft and disconnect pitman arm. Disconnect steering damper from front axle. Remove steering knuckle-to-front axle bolts and remove steering linkage assembly from vehicle.

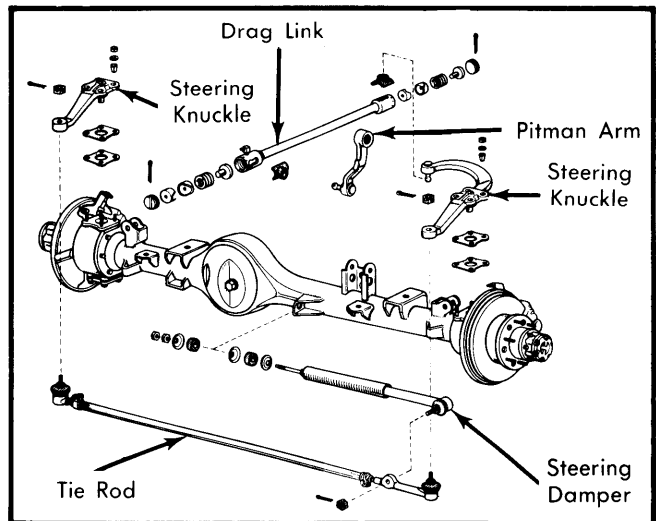

**Fig. 2 Exploded View of Toyota Steering Linkage (Pickup 4-WD)**

**Installation** — To install steering linkage, reverse removal procedure and note the following: Make sure pitman arm-to-sector shaft marks are aligned. To aid in toe-in adjustment, make sure tie rod lengths are to specifications. Measure tie rod lengths from center-to-center of ball joints. See *Tie Rod Length* chart.

Tie Rod Length	
Application	In. (mm)
Celica, Corona .....	12.60 (320)
Corolla .....	12.52 (318)
Cressida .....	14.06 (357)
Pickup	
2-WD .....	12.36 (314)
4-WD .....	47.24 (1200)

# Steering Gears & Linkage

## TOYOTA (EXC. LAND CRUISER) RECIRCULATING BALL (Cont.)

### OVERHAUL

#### STEERING GEAR

**Disassembly - 1)** On all models except Pickup 4-WD, mark pitman arm at sector shaft and remove pitman arm. Remove sector shaft adjusting screw lock nut. Remove sector shaft cover, then sector shaft. Be careful not to lose adjusting screw and shim. Remove worm assembly lock nut, adjusting screw and oil seal. Remove worm assembly and bearings.

**NOTE -** Do not disassemble ball nut from worm. If recirculating ball assembly has damaged or worn components, replace entire assembly.

**2)** On Pickup 4-WD models, mark pitman arm at sector shaft and remove pitman arm. Remove sector shaft adjusting screw lock nut. Remove sector shaft cover and sector shaft. Remove worm assembly cover and shims. Remove worm assembly with bearings.

**Inspection - 1)** Check all components for excessive wear or damage. Measure clearance between adjusting screw (with shim installed) and sector shaft. Maximum clearance should be .002" (.05 mm). If clearance is not to specifications, shims are available from .0787" (2.00 mm) to .085" (2.16 mm) in .0016" (.04 mm) increments.

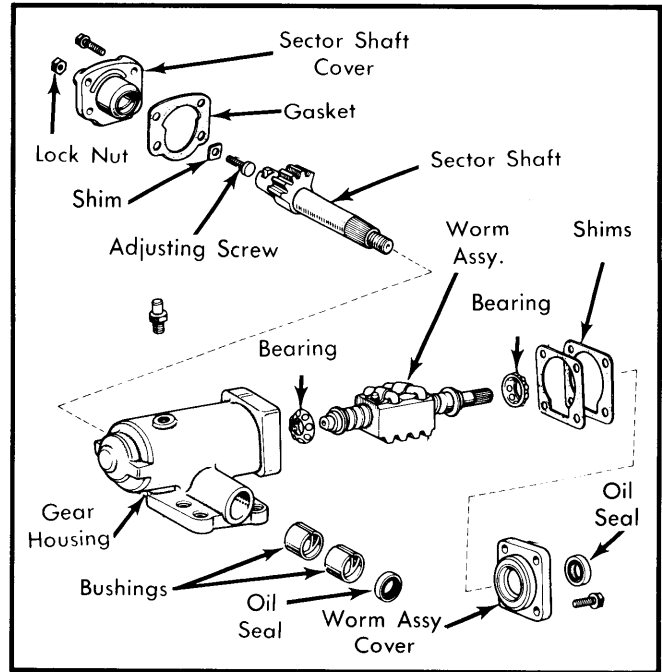

**Fig. 4 Exploded View of Steering Gear Assembly (Pickup 4-WD)**

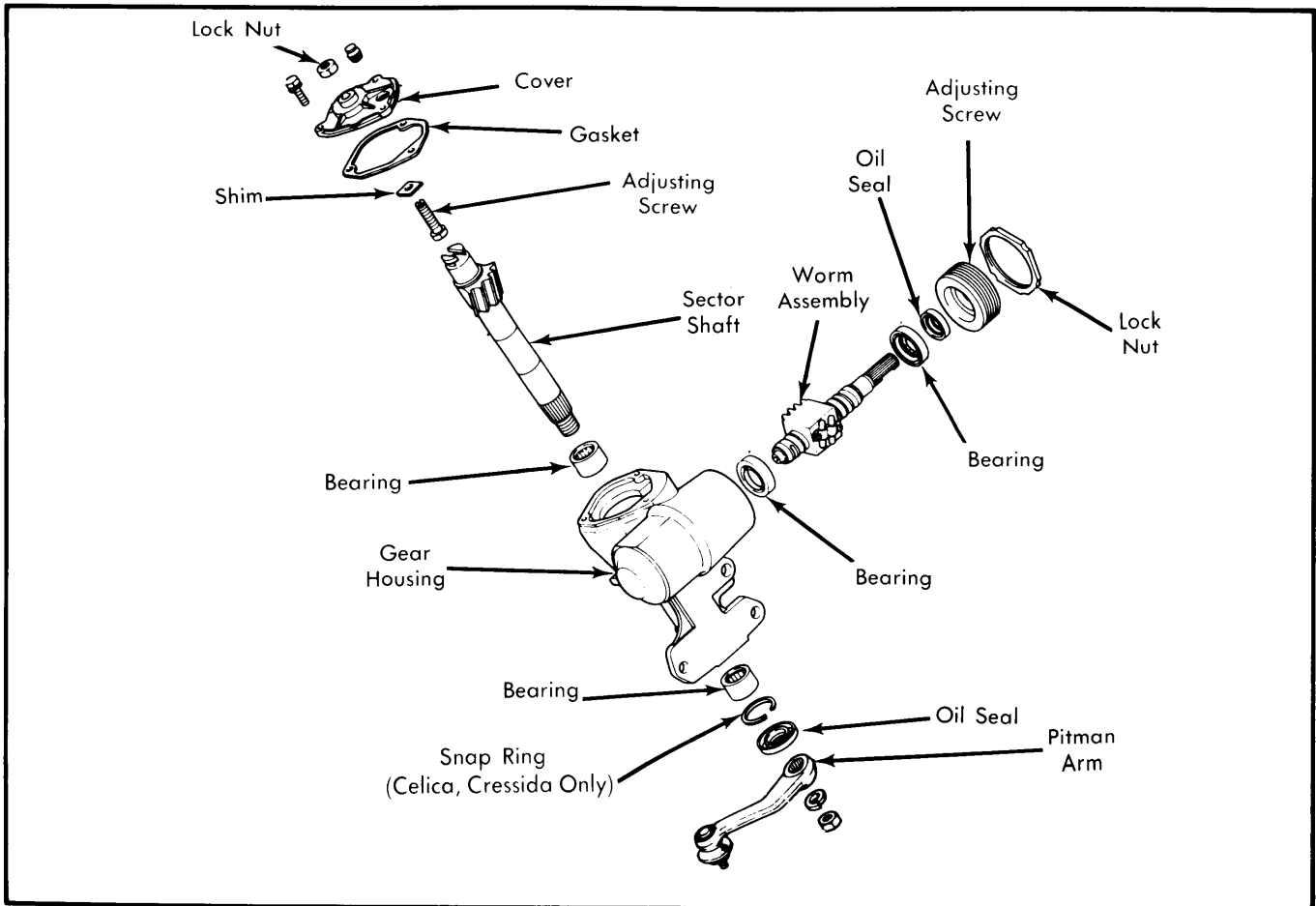

**Fig. 3 Exploded View of Steering Gear Assembly (Except Pickup 4-WD)**

## TOYOTA (EXC. LAND CRUISER) RECIRCULATING BALL (Cont.)

2) On all models except Pickup 4-WD, check sector shaft bearings for pitting and smooth operation. Replace if necessary. On Pickup 4-WD, measure sector shaft diameter. Minimum diameter is 1.258" (31.95 mm). Measure sector shaft bushings (in gear housing) for clearance between sector shaft and bushings. Maximum clearance is .004" (.1 mm). If clearance exceeds specifications and sector shaft is not worn beyond limit, replace bushings in gear housing and hone bushings to obtain standard clearance of .0004-.0024" (.01-.06 mm).

**CAUTION** — When checking worm gear and ball nut, do not let ball nut bottom out on either end of worm gear. If ball nut bottoms out, damage to worm assembly will occur.

3) On all models, check worm assembly bearings; replace bearings if damaged or worn. Check worm gear and ball nut for damage. Hold worm assembly up at an angle so ball nut will travel down worm gear (full travel) and check for smooth operation. Replace worm assembly if any damage is found or operation is not smooth.

**Reassembly & Adjustment** — 1) Grease all bearings and sliding portions of gear assembly. Install bearings on worm assembly. Install worm assembly to gear housing.

2) On all models except Pickup 4-WD, install oil seal and adjusting nut. Tighten nut while rotating worm gear to seat bearings. Loosen adjusting nut, then tighten while measuring preload. See *Initial Worm Bearing Preload chart*. With preload to specification, hold adjusting nut, install and tighten lock nut.

3) On Pickup 4-WD, install oil seal to worm assembly cover. Install same shims as removed, then install end cover and tighten bolts. Measure preload of worm assembly. See *Initial Worm Bearing Preload chart*. If not to specifications, add or remove shims until preload is to specifications. Shims are available from .002-.004" (.05-.1 mm) in .0004" (.01 mm) increments, with 2 larger sizes available; .008" (.2 mm) and .020" (.5 mm).

### Initial Worm Bearing Preload

Application	INCH Lbs. (N·m)
Celica, Corona .....	2.6-3.5 (.29-.39)
Corolla .....	1.7-3.5 (.19-.39)
Cressida .....	2.6-3.5 (.29-.39)
Pickup	
2-WD .....	2.6-4.3 (.29-.47)
4-WD .....	3.0-5.6 (.33-.62)

4) Center ball nut on worm shaft and install sector shaft so center teeth of both are meshed together. Install shim (selected previously) to adjusting screw and install to sector shaft.

5) Install sector shaft end cover to gear housing and loosen adjusting nut as far as possible. Install cover bolts and tighten. Adjust final worm bearing preload by tightening adjusting screw. See *Final Worm Bearing Preload chart*. Install lock nut and tighten while holding adjusting nut from turning.

### Final Worm Bearing Preload

Application	INCH Lbs. (N·m)
Celica, Corona .....	4.3-5.2 (.47-.57)
Corolla, Cressida .....	2.6-3.5 (.29-.39)
Pickup	
2-WD .....	5.2-7.4 (.57-.81)
4-WD .....	6.9-9.5 (.80-1.0)

6) Install pitman arm and nut (aligning mating marks). Attach dial indicator so plunger touches end of pitman arm. Sector shaft should have no backlash when measured at any point 100° on either side of centered position.

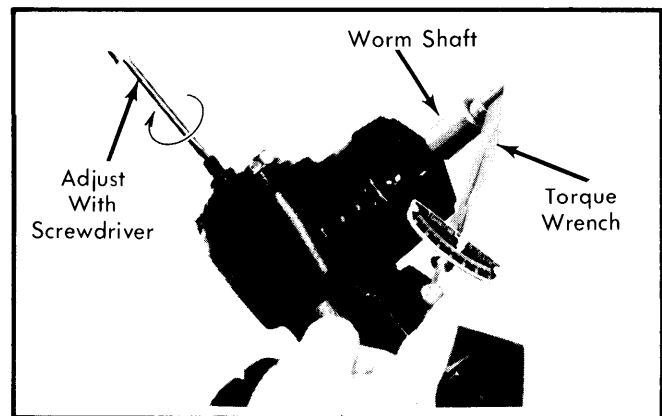

Fig. 5 Measuring Final Worm Bearing Preload

### TIGHTENING SPECIFICATIONS

Application	Ft. Lbs. (N·m)
Ball Joint Nuts (All)	
Pickup .....	Ⓞ54-80 (73-109)
All Other Models .....	36-51 (49-69)
Idle Arm Nut	
Pickup (2-WD Only) .....	58-87 (79-118)
All Other Models .....	51-65 (69-88)
Pitman Arm-to-Sector Shaft Nut	
Corolla .....	72-101 (98-137)
Pickup	
2-WD .....	80-90 (109-122)
4-WD .....	109-137 (158-186)
All Other Models .....	80-101 (109-137)
Sector Shaft Adjusting Screw Lock Nut	
Corona .....	15-25 (20-34)
Pickup	
2-WD .....	14-22 (19-30)
4-WD .....	25-36 (34-49)
All Other Models .....	14-22 (19-30)
Worm Assy. Adjusting Screw Lock Nut	
Corona .....	166-188 (226-256)
Pickup (2-WD Only) .....	166-188 (226-256)
All Other Models .....	94-123 (128-167)

Ⓞ — Damper-to-relay rod should be 36-51 ft. lbs. (49-69 N·m).