

## RENAULT RACK & PINION

Le Car

### DESCRIPTION

Vehicles are fitted with a rack and pinion steering gear, which has direct steering linkage (tie rods) to each front wheel. Steering housing is mounted to front crossmember and connected to steering column through a flexible coupling.

### ADJUSTMENT

#### STEERING GEAR HEIGHT (TOE-OUT)

**NOTE** — This adjustment must be performed whenever steering gear is removed or replaced.

1) Place vehicle on lift, or alignment rack, with front wheels on radius gauges. Attach a brake press to pedal (to prevent rolling movement of wheels). Set steering at center point and lock in position with suitable holding tool (MS. 504) attached to steering wheel.

2) Load front of vehicle until measurement from centerline of front wheel to bottom of lower frame member (at front wheel) is 4.313" (110 mm). Mount scale boards (T. Av. 552) on side of body so distance from wheel center to board is 51.188" (1300 mm). See Fig. 1.

3) Mount measuring tools on both front wheels of vehicle so pointers are in line with crosses on scale boards. Remove load from vehicle (and raise with jack if necessary) so position is 3.125" (79 mm) higher than loaded position. Pointer should move to 6-7.75 on scale board. If not, steering gear must be adjusted.

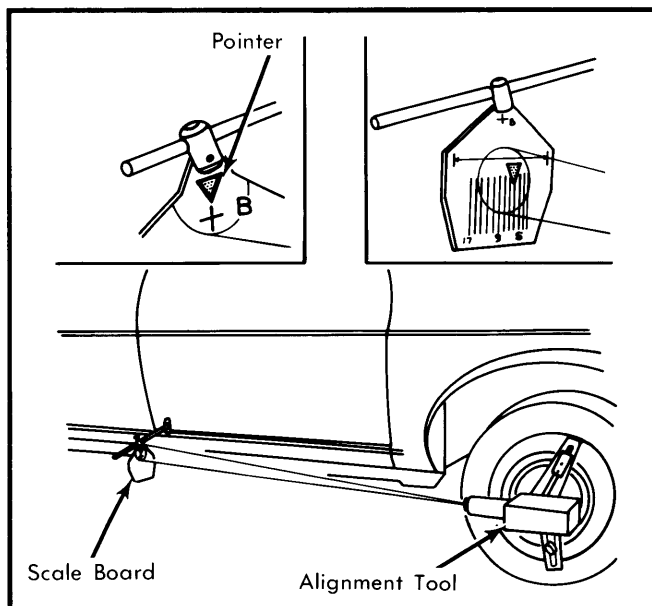

Fig. 1 Measurements for Steering Gear

4) Slotted shims are used to adjust steering gear. Position of slot in shim varies to move gear up and down. To replace or adjust shims, remove transaxle cover. Loosen steering gear bolts and remove adjusting shims. See Fig. 2.

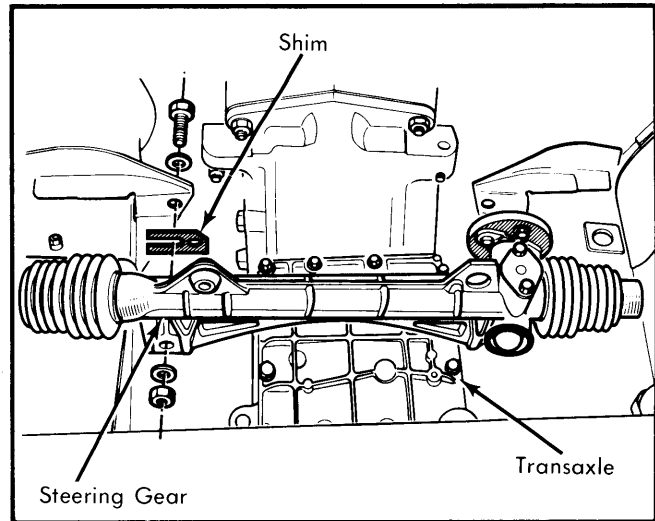

Fig. 2 Location of Adjustment Shim

#### SETTING STEERING CENTER POINT

To find center steering point, set center of rivet head on flexible coupling in line with index mark on pinion housing. This should result in a measurement of 2.813" (71 mm).

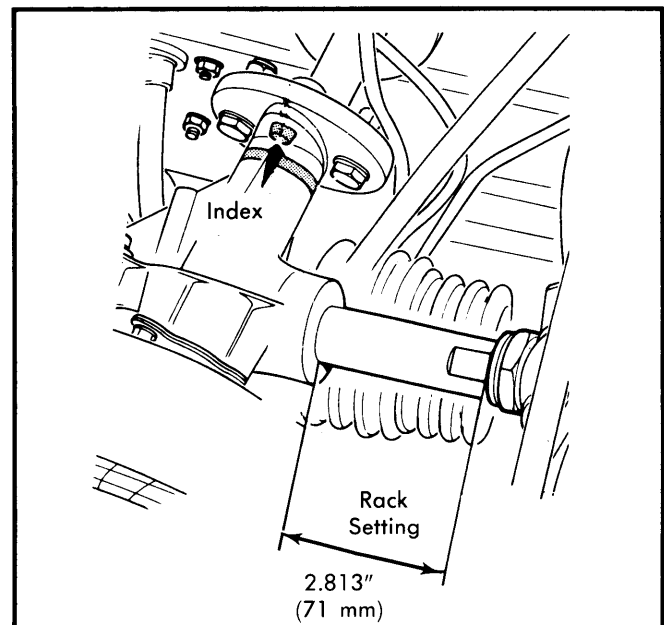

Fig. 3 Steering Center Measurement

### REMOVAL & INSTALLATION

#### STEERING GEAR

**Removal** — 1) Remove spare tire and disconnect battery. Remove air cleaner and cooling fan relay, without disconnecting wiring. Remove governor, connector, valve and air pump pipe. Remove air filter bracket bolts and place assembly on engine.

2) Remove air pump filter. Remove steering shaft flexible coupling bolts and gear mounting bolts. Disconnect tie rod ends and remove steering gear. Mark shim location to reinstall in correct position.

# Steering Gears & Linkage

## RENAULT RACK & PINION (Cont.)

**Installation** — To install, reverse removal procedure, noting the following: Coat tie rod end connections with grease. Check condition of bellows and clamps. Align tie rod connecting bolts horizontally. After steering gear is installed, check height setting and alignment.

### OVERHAUL

#### STEERING GEAR

**Disassembly** — 1) Loosen rack and locknut. Remove rack end fitting, opposite pinion, noting the number of turns required. Take off bellows, circlip, and thrust washer. Pry out rubber washer.

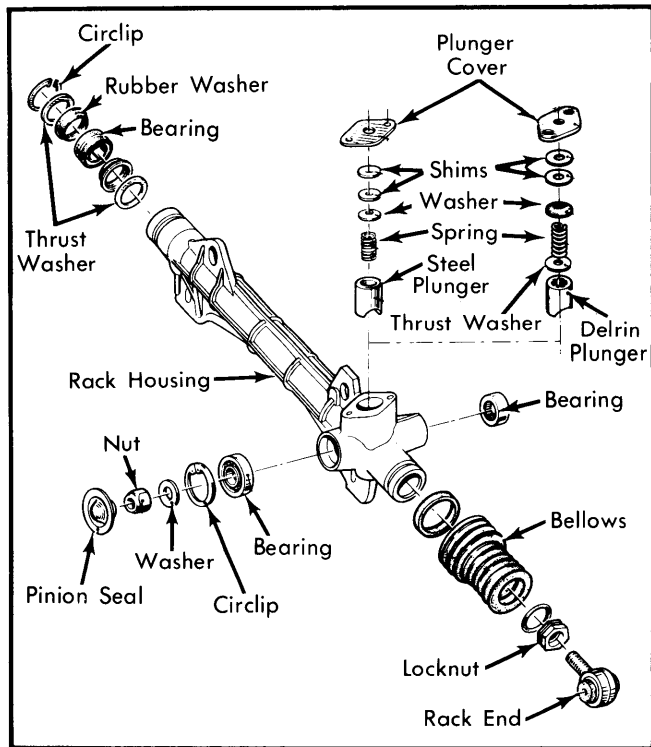

**Fig. 4 Exploded View of Steering Gear Assembly**

2) Make a bearing removal tool by drilling two .156" (4 mm) holes, 1.063" (27 mm) apart in a piece of steel strap. Turn two .125" (3 mm) screws into old bearing and turn pinion shaft to remove bearing.

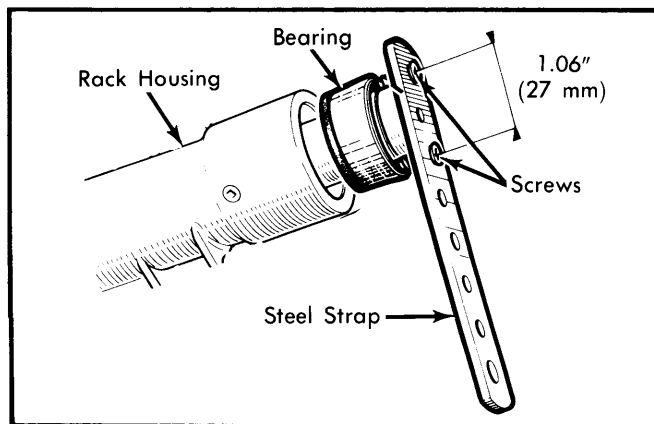

**Fig. 5 Removal of Rack Bearing**

3) Remove plunger cover, washers, spring and plunger. Pry out pinion seal plug, then remove pinion nut and washer. Pull out pinion and rack. Remove circlip and tap out bearings.

**Inspection** — Clean all parts with soft cloth and check for excessive wear or damage. Replace parts if necessary.

**Reassembly & Adjustment** — 1) Tap pinion bearings into place. Replace thrust washers, rubber rings and bushing in end of rack housing. Be sure slot is clear, and refit circlip. Spread Molykote grease over rack and pinion, then center rack in housing and install pinion. Replace washer, nut, and seal.

2) Grease plunger, spring and washers, and replace in housing. Fabricate a dial indicator bracket using a spare plunger cover. Drill a hole in the center and weld on a flange to hold indicator outer shaft. See Fig. 6.

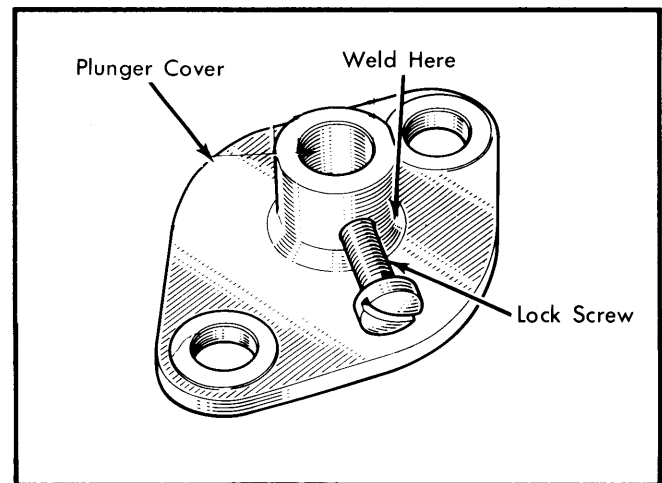

**Fig. 6 Tool for Rack Play Measurement**

3) Measure plunger movement while turning pinion. Set rack at position of greatest measurement, then reset dial indicator to zero. Pry rack back and forth without moving from position, and measure play on indicator.

4) Select a shim .0016" (.04 mm) smaller than measured play, then remove spare cover, insert shim, and replace plunger cover. Tighten cover bolts to specification.

### TIGHTENING SPECIFICATIONS

Application	Ft. Lbs. (N·m)
Flexible Coupling Bolts	11 (15)
Gear-to-Frame Bolts	25 (34)
Pinion Nut	7.5 (10)
Plunger Cover Bolts	7.5 (10)
Tie Rod-to-Rack Bolts	25 (34)