

PORSCHE RACK & PINION

911SC
924

DESCRIPTION

Porsche models use rack and pinion steering. Tie rods on 911SC attach to rack with yoke and eyebolts, while the 924 uses a ball swivel joint. Pinion on 924 is offset to the left of center. Pinion on 911SC is centered in rack housing. Pinion shafts on all models are supported by ball bearings.

ADJUSTMENT

STEERING GEAR

Steering gear adjusting methods vary according to type of steering rack pressure block: (1) Steel pressure block with plastic contact surface and external housing dust boot seat; (2) Plastic pressure block with no external housing dust boot seat; (3) Adjusting screw on 924 extends through cover to take play out of steering rack.

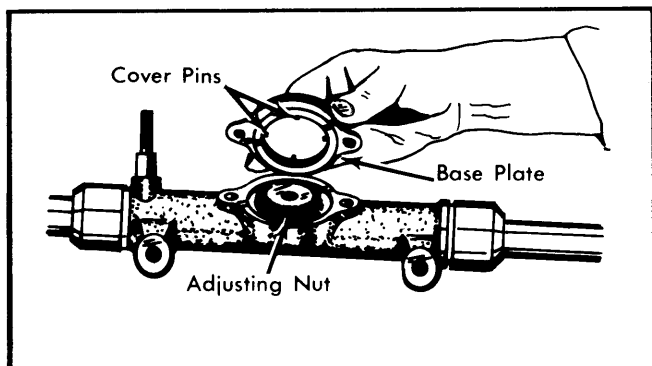

Fig. 1 Adjusting Nut with Cover

Steel Pressure Block Type – 1) With housing assembly in padded vise, detach base plate. Tighten adjusting nut seating contact. Back nut off contact by 3 teeth.

NOTE – Base plate has integral pins which may be used as a wrench for this adjustment.

2) Check steering gear drag at pinion flange, using an INCH lb. torque wrench. A measurement of 7 INCH lbs. (.8 N·m) should be obtained. If beyond this measurement, loosen adjusting nut. If this measurement is not less than 3.5 INCH lbs. (.39 N·m), do not retighten adjusting nut. Install base plate with gasket.

NOTE – When installing base plate, pin in plate must fit easily between teeth of adjusting nut. If necessary, move nut slightly.

Plastic Pressure Block Type – Remove base plate and tighten adjusting nut until 7 INCH lbs. (.8 N·m) torque is obtained, using method as previously described. Install base plate with gasket.

External Adjustment (924 Only) – With rack centered, loosen lock nut and tighten adjusting screw until it just touches thrust washer. Hold screw and tighten lock nut.

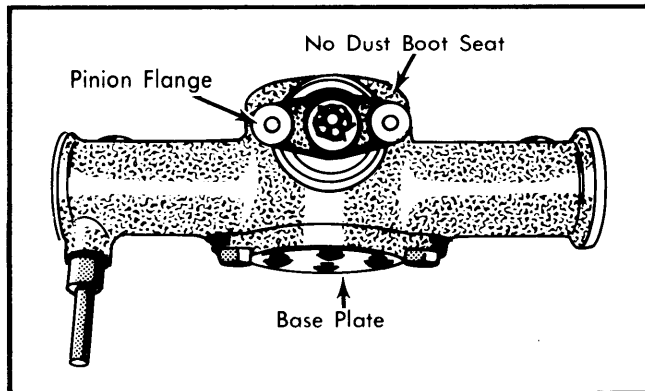

Fig. 2 Plastic Pressure Block Housing Assembly

REMOVAL & INSTALLATION

STEERING GEAR

Removal – 1) Remove bottom bolt attaching universal joint to pinion shaft. Remove nuts and detach tie rod ball joints from steering knuckles.

2) Remove steering housing retaining bolts and extract entire steering housing from right side of vehicle. Detach track rods from rack.

Installation – To install, reverse removal procedures noting that indentation in pinion shaft must line up with bolt hole in lower universal joint. On 924 only, insert special centering bolt (9116) to center gear during installation.

OVERHAUL

STEERING GEAR

Disassembly – 1) Mount steering housing in padded vise and remove base plate retaining bolts. Unscrew adjusting nut (base plate may be used as wrench). Remove pressure block and spring.

2) Move steering rack to either lock position and remove castellated nut. Using suitable puller (P 293), remove flange from pinion. Remove oil seal, lock ring and spacer. Using suitable puller (P 282), remove pinion from pinion carrier (ensure bearing does not bind against housing). Remove Woodruff key from pinion and press bearing off pinion.

3) Mark position of rack (for assembly), remove from housing, and withdraw pinion carrier. Press bearing out of pinion carrier. Remove rack bushing spring retainer from end of housing. Extract support ring and drive rack bushing out.

Steering Gears & Linkage

PORSCHE RACK & PINION (Cont.)

Reassembly — Reverse disassembly procedure, noting the following: Coat all components with suitable lubricant, then fill housing with gear lubricant using bolt hole opposite base plate. Use shims to adjust pinion axial play to zero.

EYEBOLT (911SC)

CAUTION — Eyebolt must be installed in precise position to ensure free movement of steering components and exact guiding of track rod.

Disassembly — Clamp gear into special tool (P 285b) without washers. Remove clamps on outer end of bellows and pull bellows off holder. Loosen bellows holder with hook spanner and unscrew eyebolt and bellows holder.

Inspection — Check eyebolt, bellows and clamps for visible wear. Replace as required.

Reassembly — Mount bellows on housing. Screw bellows holder on eyebolt. Coat eyebolt threads and rack face end with sealer. Install eyebolts. Attach steering gear, without

washers, to original holding tool (P 285b). Locating pins should slide easily into eyebolts, with flattened end resting against outer pin. Tighten bellows holder. Clamp bellows to gear assembly.

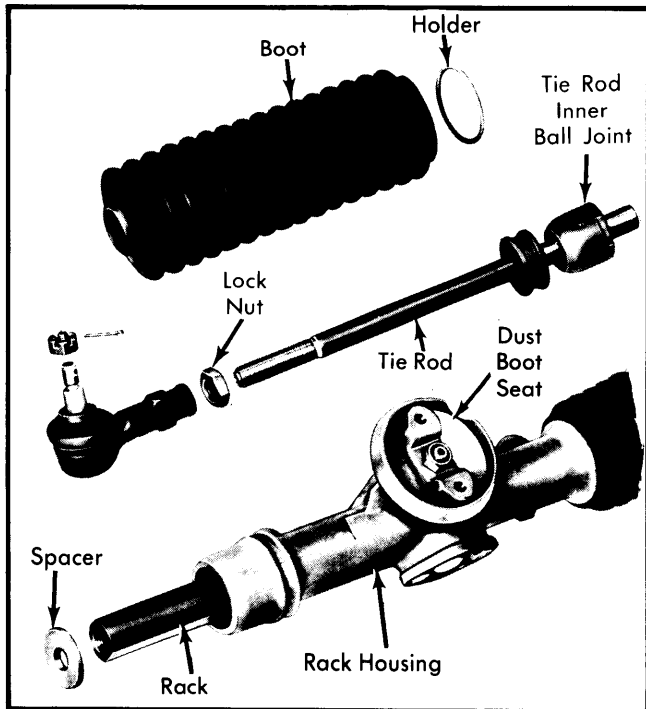

Fig. 3 Exploded View of 911SC Steering Gear Assembly

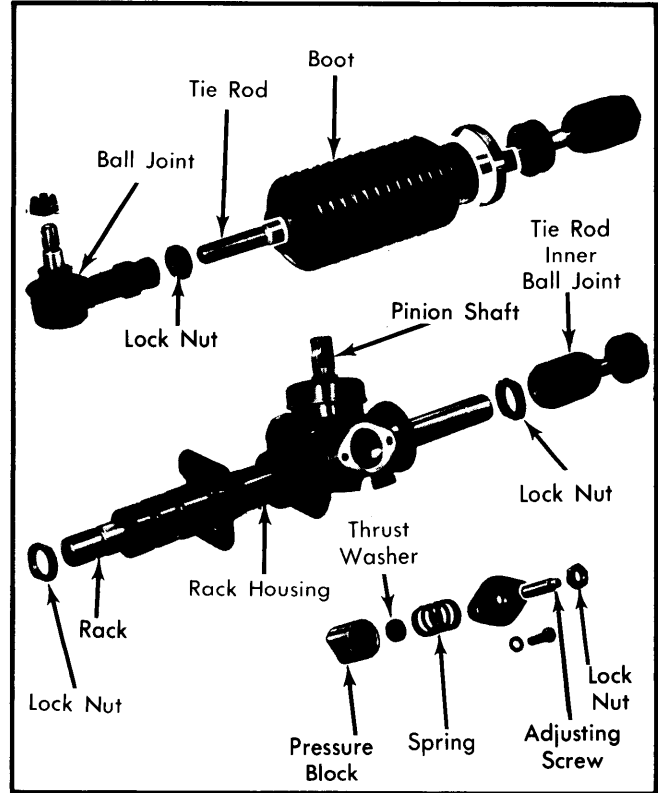

Fig. 4 Exploded View of Porsche 924 Steering Gear Assembly

TIGHTENING SPECIFICATIONS

Application	Ft. Lbs. (N*m)
Housing-to-Crossmember	
911SC	34 (46)
924	14-17 (19-23)
Tie Rod-to-Steering Knuckle	
911SC	33 (45)
924	22-36 (30-49)
"U" Joint Coupling	23 (31)