

# Steering Gears & Linkage

## DATSUN 280ZX, 310 & 810 RACK & PINION

### DESCRIPTION

Steering assembly is a direct-acting rack and pinion system. Unit consists of a rack bar and toothed pinion, both working in the plain bearing of the rack housing. Backlash is held to zero by the retainer and retainer spring.

### REMOVAL & INSTALLATION

**Removal** — 1) Raise and support front of vehicle. On 310 and 810 models, remove joint cover and loosen bolts attaching steering column to lower joint. On 280ZX models, loosen bolt attaching lower joint shaft to rubber coupling. On all models, remove bolt attaching lower joint to steering pinion gear and remove lower joint.

2) Disconnect tie rod ball joints from steering knuckles. Remove steering rack housing mounting clamp bolts, then remove complete steering gear assembly from vehicle.

**NOTE** — Raise front engine mount approximately  $\frac{1}{2}$ " (with jack) before trying to remove steering gear.

**Installation** — Install in reverse order of removal procedure. Check wheel alignment. For wheel alignment procedures, see Datsun in WHEEL ALIGNMENT section.

### ADJUSTMENT

**NOTE** — Adjustments are performed during gear assembly process. See Overhaul as outlined.

### OVERHAUL

**Disassembly** — 1) Clamp steering gear and linkage in a padded vise. Remove both dust boot clamps. Loosen inner joint lock nut and remove tie rod from rack.

**NOTE** — Do not disassemble inner joint assembly and tie rod socket assembly.

2) Loosen adjuster lock nut and remove retainer adjust screw. Remove retainer spring and steering gear retainer out of steering gear housing. Remove oil seal and pry off snap ring from steering gear housing. Remove steering pinion assembly and rack from steering gear housing.

3) Pry off snap ring securing pinion bearing from pinion gear. Press bearing from pinion gear, then remove inner snap ring from pinion gear.

4) On 310 models, remove steering gear rubber mount bushing by striking with rubber mallet. Remove snap ring and bushing from gear housing.

**Inspection** — Check rack and pinion gear for wear or damage, replace if necessary. Inspect tie rod inner socket for smooth operation and for excessive looseness, replace if necessary. Replace all oil seals. On 310 models, check rack bushing (in gear housing) for wear by measuring amount of play of rack when moved up and down then sideways. Play for up and down movement should be less than .020" (.5 mm) and less than .028" (.7 mm) for sideways movement.

**Reassembly and Adjustment** — 1) Install inner snap ring to pinion gear and then press bearing onto pinion gear. Install outer snap ring onto pinion gear. Outer snap ring thickness should be selected so that bearing play is less than .004" (.1 mm).

2) On 310 models, install rubber mount bushing to housing and secure with snap ring. Install rubber mount with plate onto end of housing. Make sure cut out section of rubber mount is aligned with hole in housing and that ventilation hole is not clogged with grease.

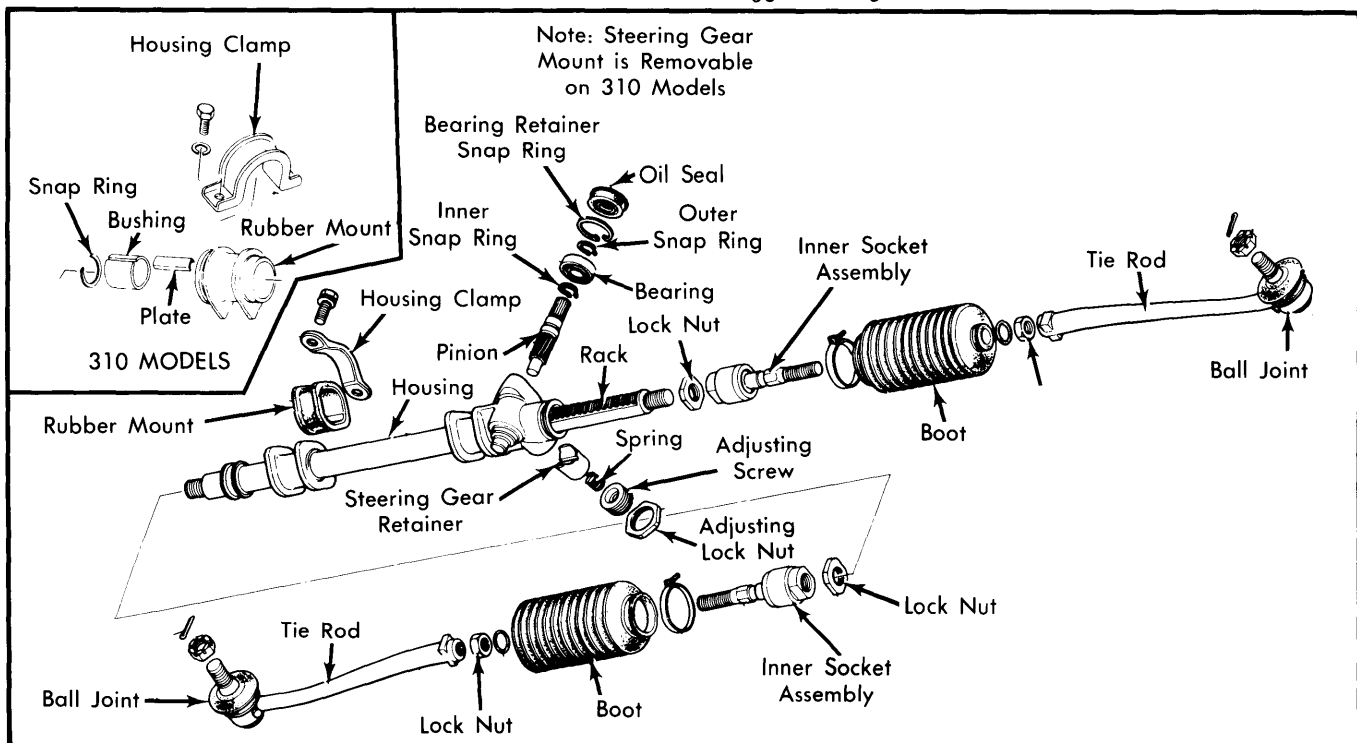

Fig. 1 Exploded View of Datsun Rack and Pinion Steering Gear Assembly

## DATSUN 280ZX, 310 & 810 RACK & PINION (Cont.)

3) On all models, clamp steering gear in padded vise. Coat rack teeth and friction surfaces of rack with grease. Install rack into housing from pinion gear side and make sure rack teeth are facing correct direction. Install pinion gear (coated with grease), make sure pinion gear teeth and rack teeth mesh properly. Make sure rack protrudes same amount from each end of housing.

4) Install snap ring to steering gear housing (snap ring retains pinion bearing in place). Snap ring thickness should be selected so that pinion gear movement is less than .004" (.1 mm). Pack grease seal with grease and install. Make sure pinion assembly rotates smoothly.

5) Apply grease to steering gear retainer and insert gear retainer and retainer spring into housing. Turn adjusting screw in and install lock nut. Fully tighten adjusting screw then back off approximately 20-25°. Apply liquid sealant around lock nut and tighten lock nut.

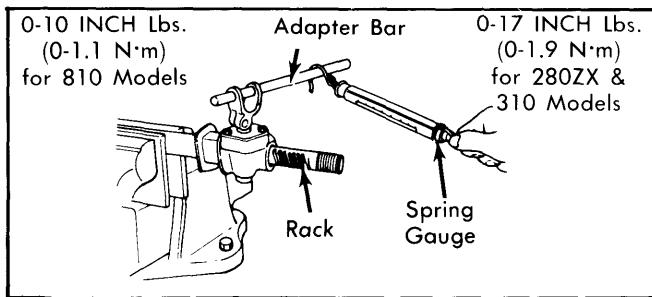

Fig. 2 Measuring Pinion Shaft Rotating Torque

6) With steering gear assembled, measure torque required to keep pinion and rack in motion. Install steering gear in padded vise and attach torque wrench to bar and spring gauge. See Fig. 2. Pinion turning torque should be 0-17 INCH Lbs. (1.9 N·m) for 280ZX & 310 models; 0-10 INCH Lbs. (0-1.1 N·m) for 810 models.

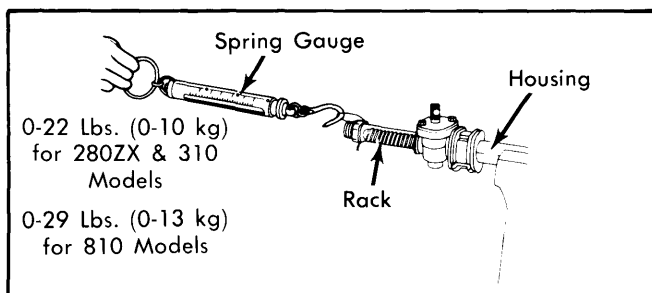

Fig. 3 Measuring Steering Gear Rack Pulling Force

7) Measure force to pull rack from neutral (center) position. See Fig. 3. Force should be 0-22 Lbs. (0-10 kg) for 280ZX & 310 models; 0-29 Lbs. (0-13 kg) for 810 models. Install rubber boot and clamp onto tie rod. Thread lock nut over threaded portion of rack. Apply grease to sliding surfaces of tie rod inner socket and spring seat. Install tie rod assembly to rack end together with inner spring and spring seat.

**NOTE** — On 280ZX models, tie rod for left side is marked with an "L". No mark is used for right side tie rod.

8) Screw inner socket portion until ball seat reaches rack end and then tighten lock nut. Upon completion of tie rod assembly, measure swinging torque and axial play of tie rod inner socket. Swinging torque (measured at outer end of tie rod) should be 0-43 INCH Lbs. (0-4.7 N·m) on 280ZX models and 13-61 INCH Lbs. (1.4-6.7 N·m) on 310 models and 0-26 INCH Lbs. (0-2.9 N·m) for 810 models. 310 and 810 models should have no axial play.

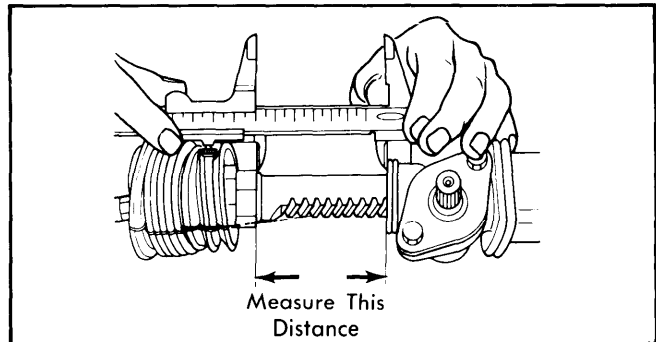

Fig. 4 Measuring Steering Gear Rack Protrusion

9) Measure rack protrusion on both sides of housing. 280ZX models should be 2.614" (66.4 mm), 310 models should be 2.680" (68 mm) and 810 models should be 2.992" (76.0 mm). Attach boot and clamps. Insert grease nipples at both ends of housing and lubricate gear assembly until a small amount of grease appears at boot outlet hole. Adjust tie rod length so that distance from outer side of lock nut to end of boot mounting groove is 1.161" (29.5 mm) on 280ZX models, 5.24" (133 mm) on 310 models and 1.421" (36.09 mm) on 810 models.

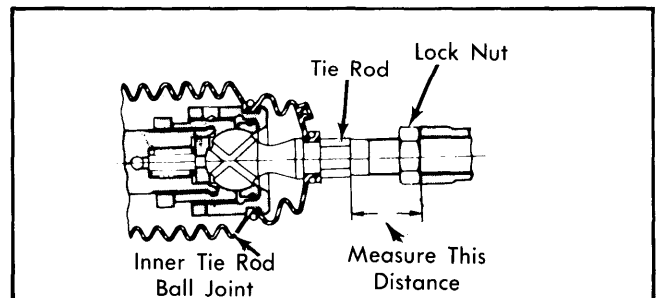

Fig. 5 Adjusting Steering Gear Tie Rod Length

### TIGHTENING SPECIFICATIONS

Application	Ft. Lbs. (N·m)
Inner Socket Lock Nut .....	58-72 (79-98)
Tie Rod Ball Joint Nut .....	40-47 (54-64)
Tie Rod-to-Socket Lock Nut	
280ZX & 810 .....	58-72 (79-98)
310 .....	27-34 (36-46)