

# Steering Wheel & Column Switches<sup>11-17</sup>

## VOLKSWAGEN (Cont.)

**Installation** — To install, reverse removal procedures and note: Drive spacer sleeve on until upper end of spacer is flush with bevel on steering column. Make sure steering wheel is installed with lug for turn signal cancel mechanism facing left side of vehicle.

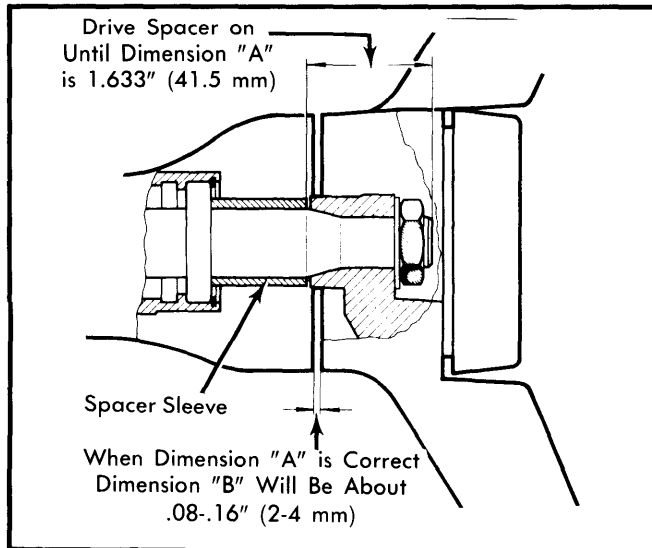

**Fig. 2** Dimensions for Installing Spacer Sleeve

**Removal (All Others)** — Disconnect battery ground cable and remove steering wheel as previously outlined. Remove 3 screws securing switch assembly to steering lock mechanism. Force switch assembly toward instrument panel and remove spacer sleeve. Pull up on switch assembly and disconnect electrical wires. Remove switch and separate windshield wiper lever from dimmer/turn signal lever.

**Installation** — Refit switches together with screw and spacer sleeve. Slide switch assembly onto column and hook up wires. Spacer sleeve must be installed as shown in Fig. 2.

### COLUMN LOCK & IGNITION SWITCH

**Removal** — 1) Disconnect battery ground cable. Remove steering wheel and combination switch as previously outlined. If necessary, drill a .125" (3.18 mm) hole in cylinder to gain access to cylinder release pin. Refer to Fig. 3 for location of access hole.

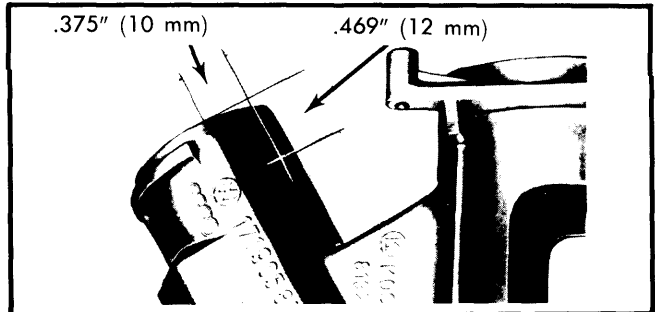

**Fig. 3** Location for Drilling into Lock Cylinder

2) Insert a pin through hole and press down spring holding lock cylinder in housing. It may be necessary to insert key to pull out cylinder. To remove ignition switch, remove locking mechanism shear bolts and remove switch housing. Remove set screw on back side of switch, near wire connector. Remove ignition switch.

**Installation** — To install, reverse removal procedure and note: Before shearing bolt head, set clearance between steering wheel and switch to .08-.12" (2-3 mm).

## VOLVO

Bertone  
Diesel  
DL

GL  
GLE  
GLT Turbo

### REMOVAL & INSTALLATION

#### HORN PAD & STEERING WHEEL

**Removal** — Disconnect battery cable. Remove horn pad by squeezing top and bottom towards center of pad and unfolding upper edge of pad. Disconnect electrical wires and remove steering wheel nut. Use puller (2263) to remove steering wheel.

**Installation** — To install, reverse removal procedure.

#### TURN SIGNAL & WIPER SWITCHES

**NOTE** — Steering wheel does not have to be removed to remove combination switch; however, removal of switch is easier with steering wheel removed.

**Removal** — Disconnect battery ground cable. Remove column covers from steering column. Disconnect electrical connectors from switches to be removed and remove switches.

**Installation** — To install, reverse removal procedure.

### IGNITION SWITCH & STEERING LOCK

**Removal** — Disconnect battery ground. Remove steering wheel and column covers. Remove turn signal and wiper switches. Remove upper bearing spring and race. Drill out center of shear bolts and remove with suitable screw extractor. Remove lock assembly. Disconnect electrical connections and remove ignition switch.

**Installation** — To install, reverse removal procedure and note: Position front of lock assembly 3.81" (97 mm) from upper end of steering column.

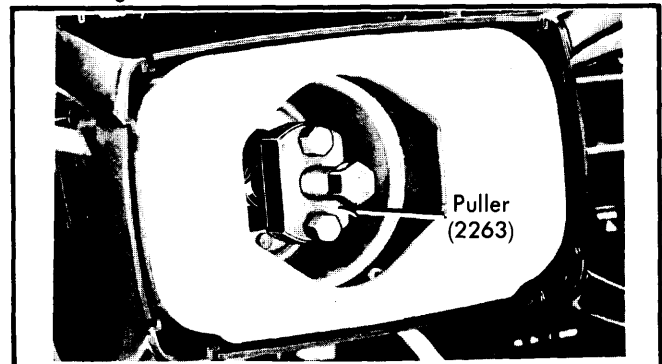

**Fig. 1** Using Puller to Remove Steering Wheel