

CHRYSLER CORP. IMPORTS (Cont.)

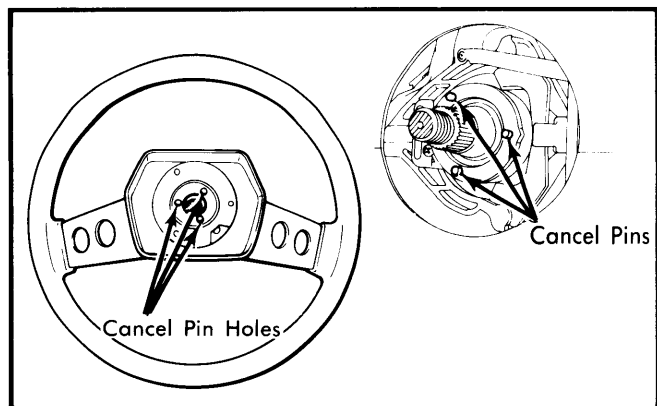

Fig. 1 Installation of Steering Wheel on Arrow, Challenger, Colt and Sapporo Models

2) To install steering wheel, place front wheels in straight ahead position. On Arrow, Challenger, Colt and Sapporo models, align cancel pins of column switch with holes in bottom of steering wheel. On all models, refit steering wheel with index marks aligned. Tighten nut and install horn pad.

STEERING LOCK

Removal — With steering wheel removed, disconnect negative battery cable. Remove column levers and switches. Cut a slot in mounting head screws and bracket with a hack saw. Remove screws and remove steering wheel lock.

Installation — To install reverse removal procedure and install new bracket and screws.

COURIER

REMOVAL & INSTALLATION

STEERING WHEEL & COMBINATION SWITCH

Removal — 1) Disconnect battery ground cable. Remove steering wheel nut cover. Index mark main shaft and steering wheel. Disconnect electrical leads. Pull steering wheel from shaft.

2) Remove plastic hazard light indicator and steering column shroud. Disconnect electrical wires at base of steering column. Remove headlight switch knob from shaft.

3) Remove snap ring retaining switch and force turn indicator cancelling cam off shaft. Take out single bolt, near bottom of switch, and pull out complete switch assembly.

Installation — 1) Fit switch assembly on steering column then, refit one retaining bolt. Place turn indicator cancelling cam into position and install snap ring. Reconnect electrical plug at column base.

2) Insert and tighten headlight knob switch. Install column shroud and plastic hazard light indicator. Refit steering wheel with index marks aligned. Connect battery ground cable.

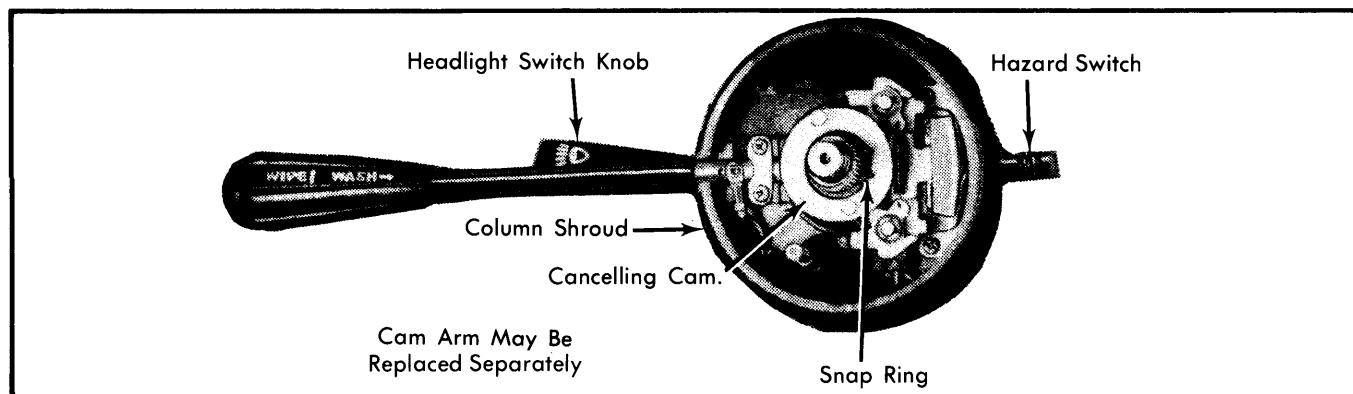

Fig. 1 Top View of Steering Column with Steering Wheel Removed to Expose Combination Switch

DATSUN

200SX
210
280ZX
310

510
810
Pickup

REMOVAL & INSTALLATION

STEERING WHEEL & HORN PAD

Removal — 1) Disconnect battery ground cable. Use the following procedures to remove horn pad for particular model:

• On 200SX, 280ZX, 310, 810 and Pickup models, pull horn pad off steering wheel.

• On 210 models, remove 3-spoke horn pad by pulling off. Remove 2-spoke horn pad by removing bolts on back side of steering wheel, then pull off pad. Remove horn wire.

• On 510 models, remove screws on back side of steering wheel and pull pad off. Remove horn wire.

11-6 Steering Wheel & Column Switches

DATSUN (Cont.)

2) Remove retaining nut. Using puller (27180001), remove steering wheel. Do not hammer on steering wheel. Pounding may cause damage to collapsible steering column.

Installation — On all models, reverse removal procedure. Grease any sliding components. Match index marks made during removal. Check operation.

COMBINATION SWITCH

Removal — Disconnect battery ground cable. Remove steering wheel. Remove steering column shrouds. Disconnect switch connector. Remove screws holding switch to column and lift switch out of shaft.

NOTE — On Pickup models switch connector is near lower edge of instrument panel.

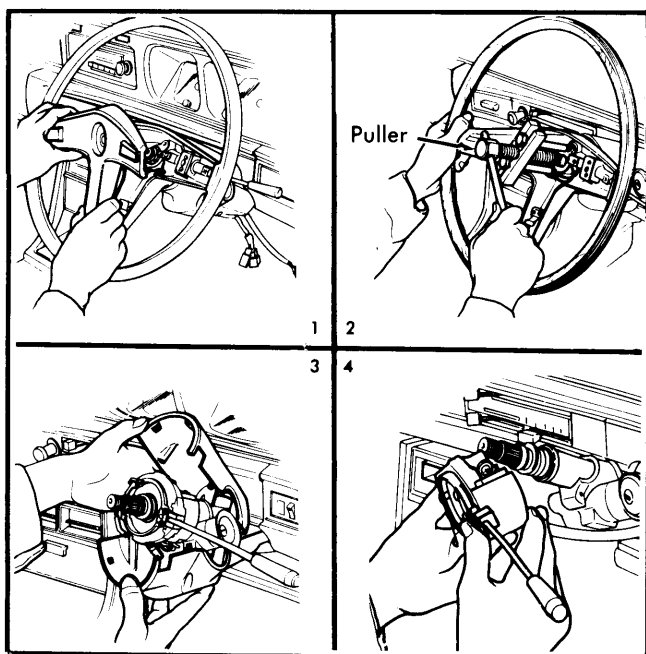

Fig. 1 Steps for Removing and Installing Steering Wheel and Combination Switch

Installation — To install, reverse removal procedure. Make sure switch tab locates in hole in column.

HAZARD WARNING SWITCH

Removal — Disconnect battery ground cable. Remove mounting screws and steering column shrouds. Disconnect lead wires at connector. Remove retaining screws and take switch out of shroud.

Installation — To install, reverse removal procedure.

STEERING LOCK & IGNITION SWITCH

Removal — Disconnect battery ground cable. Remove steering column shroud. Drill out shear bolts. Separate steering lock from column shaft. If ignition switch is to be removed, separate electrical connector, then remove small set screw holding switch body. Remove switch.

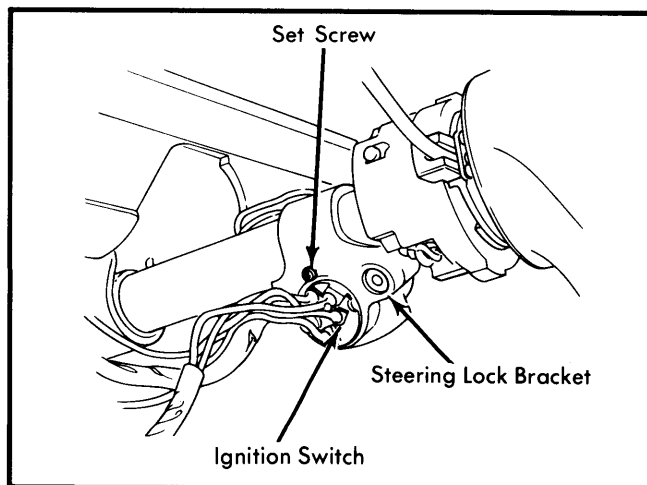

Fig. 2 Steering Lock and Ignition Switch

NOTE — It should be possible to remove ignition switch without removing steering lock. Remove small set screw.

Installation — To install, reverse removal procedure. Fit ignition switch to lock mechanism before installing lock.

Brava
Spider 2000
Strada
X1/9

REMOVAL & INSTALLATION

HORN COVER & STEERING WHEEL

Removal (Brava & Strada) — Disconnect battery ground cable. Remove steering column shrouds. From behind steering wheel, pry 2 plastic locking tabs inward to remove horn button. Remove nut and washer and remove steering wheel.

Installation — To install, reverse removal procedure.

Removal (All Others) — Disconnect battery ground cable. Remove steering column cover (if equipped) and remove horn

FIAT

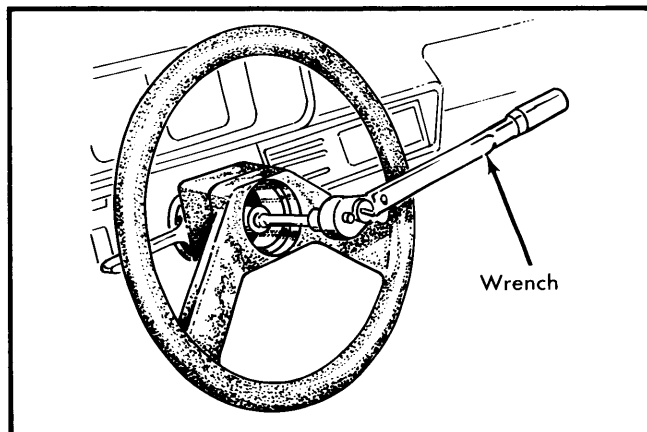

Fig. 1 Steering Wheel Removal (Brava & Strada Shown)