

VOLKSWAGEN JETTA, RABBIT & SCIROCCO

DESCRIPTION

Rear suspension is a link type with coil springs and using control arms and torsion beam for stabilization. Control arm and torsion beam are combined as one unit. Hydraulic shock absorbers are mounted inside coil springs and attached to control arm at the bottom and to vehicle body at the top.

REMOVAL & INSTALLATION

SUSPENSION STRUT & COIL SPRING

Removal — 1) Leave vehicle on ground. Take off plastic cap covering rear strut upper mounting nuts. Remove nuts.

2) Slowly raise vehicle until weight is off spring. Remove bolt holding lower end of strut shock absorber to axle beam mount. Raise vehicle until strut can be removed.

NOTE — It is not necessary to use spring compressor to disassemble strut.

Disassembly — Set strut assembly in vise. Hold piston rod and remove strut mounting nut. Take off components down to slotted nut. Remove slotted nut. Take off spacer and coil spring.

Inspection — Hand check shock absorbers for even resistance through entire piston stroke. Worn shock absorbers cannot be overhauled.

NOTE — If a coil spring is being replaced, ensure that paint stripe color code on replacement spring matches original spring code.

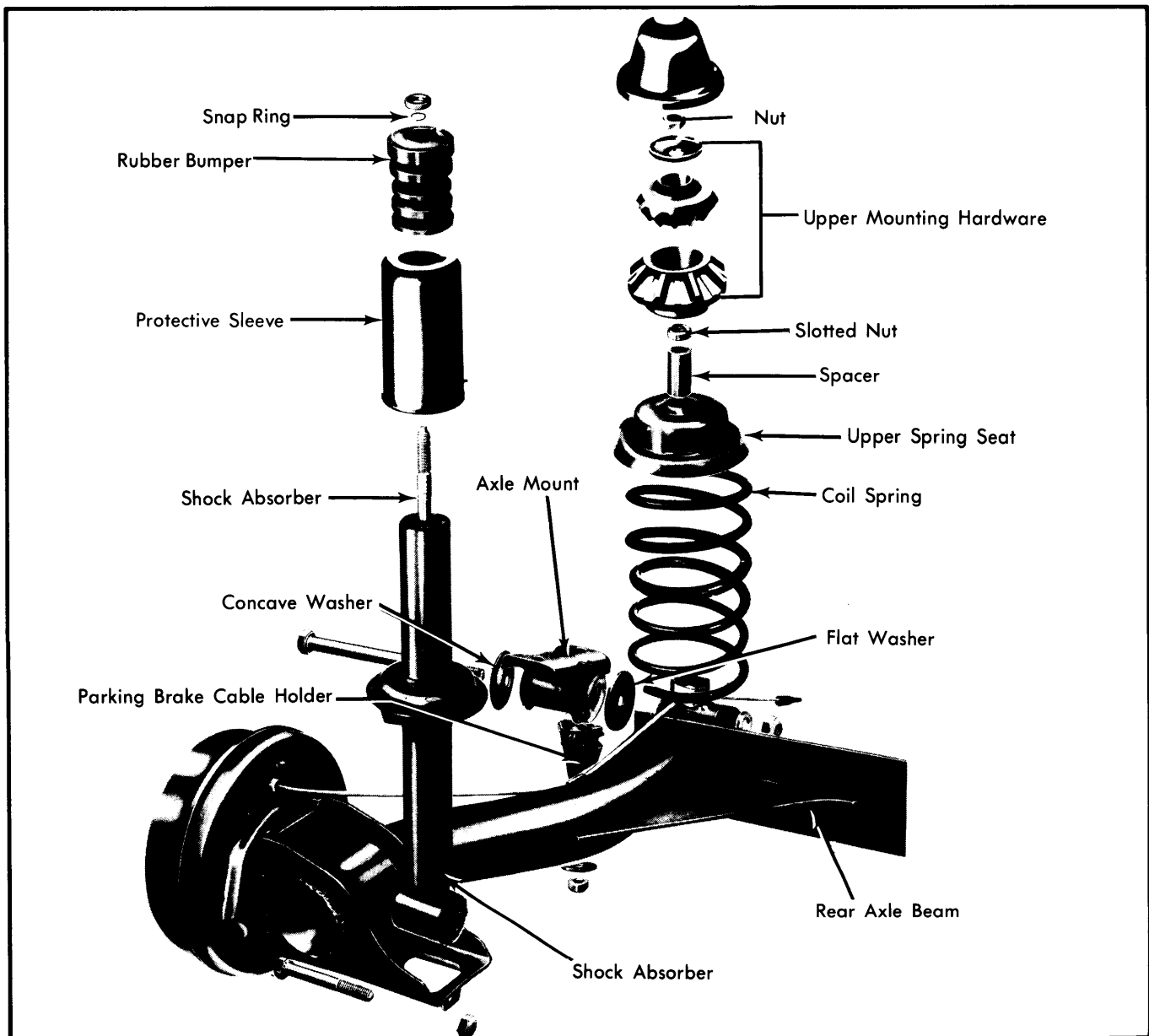

Fig. 1 Exploded View of Rear Suspension Components

Rear Suspension

VOLKSWAGEN JETTA, RABBIT & SCIROCCO (Cont.)

Reassembly — 1) Fit protective cap on shock absorber. Install rubber buffer, with small diameter end downward. Insert snap ring and washer.

2) Place spring into lower seat. Fit upper retainer with spacer sleeve. Tighten slotted nut holding piston rod. Put on remaining upper mounting hardware and tighten piston rod.

Installation — Reverse removal procedure.

SUSPENSION ASSEMBLY

Removal — 1) Leave vehicle on ground. Disconnect upper strut mounting at body. Raise vehicle and support at rear with jack stands.

2) Disconnect parking brake at holder near rear axle mount. Disconnect and plug brake lines. Leave flex hose attached to suspension.

3) Separate brake pressure regulator spring from axle beam on models so equipped. Remove both nuts mounting axle beam on each side to body.

Installation — 1) If axle beam mounting has been removed, use Fig. 2 to correctly adjust mounting pad. If pad is not correctly aligned, torsional preload of mounting bushings will be incorrect.

2) Position rear suspension on body. Refit nuts keeping axle beam to body. Raise wheel and guide upper end of strut into body mounting.

3) Connect parking brake cables. Connect brake lines. Lower vehicle and tighten upper strut mounting nuts. Bleed brake system.

AXLE BEAM PIVOT BUSHING

NOTE — Procedure given is for replacing bushing with axle beam installed in vehicle.

Removal & Installation — 1) Raise and support vehicle so that axle beam pivot bolt is not under load.

2) Remove 2 nuts holding axle beam to body and tap out pivot bolt.

3) Press out bushing. Select new bushing and press bushing into place. Loosely install mounting on axle beam. Concave washer and bolt head must face toward outside of vehicle. Bolt head must recess into washer.

4) Align mount as shown in Fig. 2. Tighten pivot bolt nut. Lower vehicle.

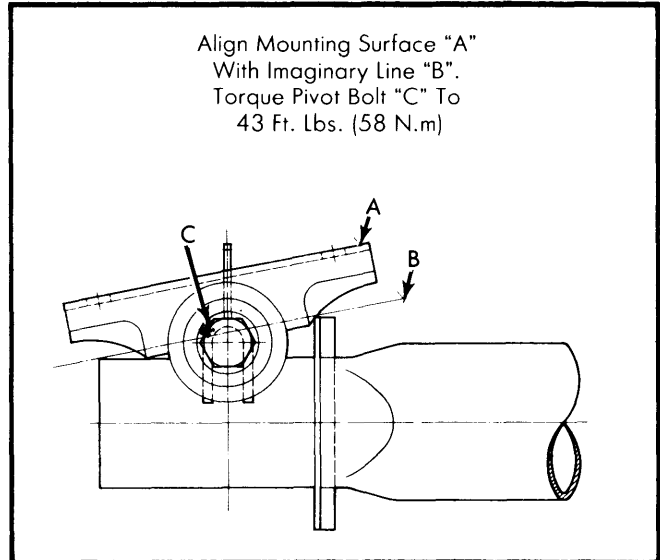

Fig. 2 Drawing Showing Correct Mounting Pad Alignment

TIGHTENING SPECIFICATIONS

Application	Ft. Lbs. (N.m)
Coil Spring Retainer-to-Piston Rod	14 (19)
Rear Axle Beam-to-Mounting Pad	43 (58)
Rear Axle Mounting-to-Body	32 (43)
Shock Absorber-to-Axle Beam	32 (43)
Shock Absorber-to-Body	23 (31)
Shock Absorber Slot Nut	15 (20)