

PORSCHE 924

DESCRIPTION

Independent torsion bar type rear suspension. Torsion bars mount in rear crossmember tube and anchor in center of tube by a splined hub. Outer ends of torsion bar mount into splined hubs integral with spring plates. Spring plates are bolted to control arm at a flange. Control arms pivot in mounts on crossmember tube and are integral with stub axle housing. Hydraulic shock absorbers mount on control arm and to upper body.

ADJUSTMENTS

WHEEL ALIGNMENT SPECIFICATIONS & PROCEDURES

See *Wheel Alignment Specifications and Procedures* in *WHEEL ALIGNMENT* Section.

REMOVAL & INSTALLATION

SHOCK ABSORBERS

Removal — Raise vehicle and place on safety stands. Remove wheel. Remove both bottom and top mounting nuts and bolts, then slide shock absorber from vehicle.

Installation — Inspect for hydraulic leaks and replace shock absorber if excessive leaking is apparent. Check shock absorber for smooth, even operation. To install, reverse removal procedure.

CONTROL ARM

Removal — 1) Remove cotter pin and loosen rear hub nut. Raise vehicle and place on safety stands. Remove wheel. Remove shock absorber.

2) Remove bolts mounting axle drive shaft to stub axle. Separate axle drive shaft from stub axle and wire out of way. Use protective cap to cover exposed end of axle drive shaft.

3) Remove drum and disconnect parking brake and hydraulic lines. Index mark spring plate in relation to a point on control arm. Remove control arm pivot bolt and remove arm from vehicle.

Installation — To install, reverse removal procedure. Tighten pivot bolt and lock in place by staking edge to metal shoulder on bracket. Align spring plate marks with those on control arm. Bleed brake system.

CROSSMEMBER TUBE

Removal — 1) Raise and support vehicle. Remove wheels. Disconnect parking brake cable from lever. Remove cable.

2) Disconnect and remove rear portion of exhaust system from catalytic converter. Remove transaxle mount nuts. Support transaxle with a chain by attaching ends to frame.

3) Disconnect shock absorbers from control arms. Support control arms with jacks or stands. Remove stabilizer bar links. Mark location of spring plate on control arm and remove camber eccentric and mounting bolts between spring plate and control arm flange.

4) Remove parking brake retainer straps from spring plates. Reattach shock absorbers temporarily. Remove control arm pivot bolts.

5) Disconnect parking brake cable from crossmember tube. Remove crossmember lower mount bolts. Remove torque strut bolts from upper mounts. Remove crossmember tube.

Installation — 1) Apply rubber lubricant to lower mount bushings. Install crossmember tube with lower mount bolts. Remove upper mounts from body and install on torque struts, but do not tighten bolts.

2) Install control arms with pivot bolts. Disconnect shock absorber from control arm. Install control arm to spring plate, but do not tighten bolts. Reinstall shock absorber to control arm.

3) Install upper mount bolts to body approximately 2-3 threads deep. Tighten torque strut-to-mount bolts first, then tighten all remaining mount bolts.

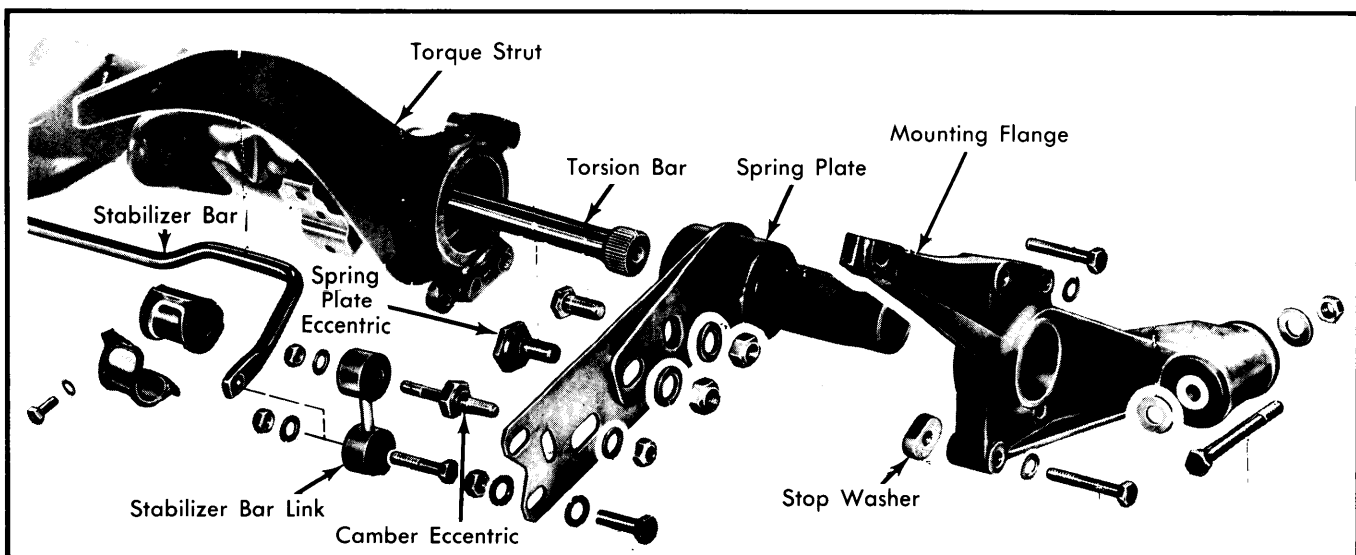

Fig. 1 Exploded View of 924 Rear Suspension

Rear Suspension

PORSCHE 924 (Cont.)

4) Lower transmission and remove support chain. Install and tighten transaxle mount nuts. Reinstall parking brake cables and retainers. Install wheels and lower vehicle.

5) Check and adjust rear axle alignment. After alignment, raise vehicle and remove rear wheels. Tighten all nuts and bolts to specifications. Install stabilizer bar links.

TORSION BARS & SPRING PLATES

Removal — With crossmember tube removed and placed in a vise, remove mounting flange bolts and flange. Pry off spring plate. Remove spring plate and withdraw torsion bars.

NOTE — *Left and right torsion bars are not interchangeable.*

Installation — 1) Position crossmember tube so that flat surface of torque strut is horizontal. Using a protractor (VW 261) and a straight edge, measure any deviation from horizontal and record that figure. Add 23 $\frac{3}{8}$ ° to recorded figure for setting spring plate angle.

2) Set protractor at indicated angle and turn spring plate or torsion bar until bubble in level is centered.

3) Install mounting flange, using rubber lubricant, with the 3 short bolts, until the long fourth bolt for stop washer can be inserted. Install mounting flange-to-torque strut bolt temporarily.

4) Compress spring plate with jack or compression tool (VW 655/3). Install spring plate stop washer and tighten bolt slightly. Remove tool, allowing spring plate to position stop washer. Tighten all flange bolts.

TIGHTENING SPECIFICATIONS	
Application	Ft. Lbs. (N.m)
Control Arm Camber Eccentric	65 (88)
Control Arm-to-Spring Plate	75 (102)
Mounting Flange-to-Body	51 (69)
Mounting Flange-to-Crossmember	33 (45)
Mounting Flange-to-Upper Mount	33 (45)
Shock Absorber-to-Body	44 (60)
Shock Absorber-to-Control Arm	44 (60)
Spring Plate Height Eccentric	177 (240)
Stabilizer Bar Link	33 (45)
Torque Strut Mount-to-Body	33 (45)
Torque Strut Mount-to-Strut	17 (23)
Upper Mount-to-Body	33 (45)