

# Rear Suspension

## MAZDA

GLC  
Except Wagon  
626  
RX7

### DESCRIPTION

Rear suspension is a coil spring type, using trailing upper and lower control arms as pivot supports. On GLC and 626 models, the coil springs mount ahead of the rear axle directly on the lower control arms. On RX7 models, coil springs mount on rear axle housing. GLC and 626 models use a lateral rod to control side-to-side axle movement, while RX7 models use a 3-piece Watt linkage. Shock absorbers are mounted behind the rear axle housing at the lower ends and to the chassis on the upper ends.

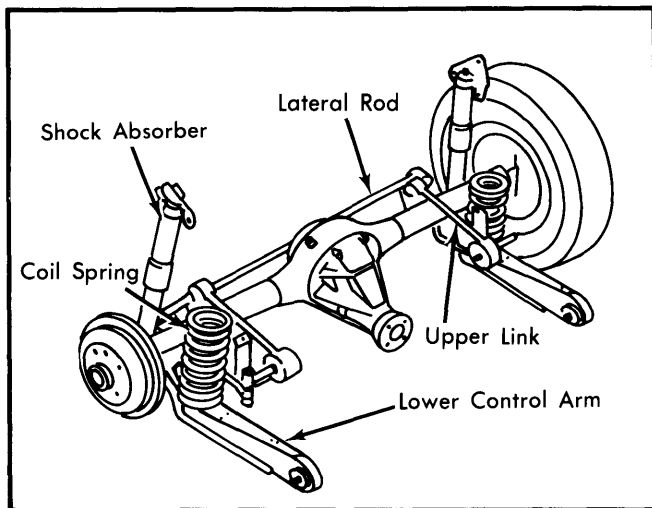

Fig. 1 GLC & 626 Rear Suspension Assembly

### REMOVAL & INSTALLATION

#### SHOCK ABSORBERS

**Removal** — Raise and support rear of vehicle. Remove wheels. Disconnect upper shock absorber mounting. Remove lower shock absorber mount nuts. Remove shock absorber.

**Installation** — To install, reverse removal procedures.

#### COIL SPRINGS

**Removal (GLC)** — Raise and support rear of vehicle. Remove rear wheels. Support rear axle housing with a jack. Remove shock absorber. Remove lower arm pivot bolt at axle housing and slowly lower axle. Remove spring.

**Removal (626)** — Disconnect shock absorber lower end. Disconnect lateral rod at axle housing. Disconnect upper and lower control pivot bolts at axle housing. Disconnect rear stabilizer bar (if equipped). Slowly lower axle and remove spring.

**Removal (RX7)** — Disconnect shock absorber lower end. Disconnect upper and lower control arm pivot bolts at axle housing. Disconnect Watt links at axle housing. Disconnect stabilizer bar (if equipped). Slowly lower axle and remove spring.

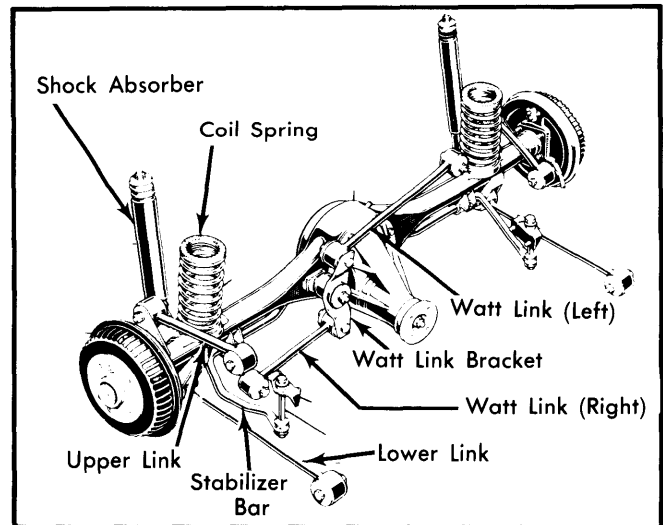

Fig. 2 RX7 Rear Suspension Assembly

**Installation (All Models)** — To install, reverse removal procedure and note the following: On 626 and RX7 models, install springs with painted marks facing toward rear axle housing. Tighten nuts and bolts after vehicle has been lowered to ground.

#### CONTROL ARMS, LINKS & RODS

**Removal** — Raise and support vehicle. Remove control arms, lateral rods or Watt links by removing attaching nuts and bolts, noting their proper installed locations.

**Inspection** — Inspect all components for wear or damage. Inspect and replace bushings as necessary.

**Installation** — To install, reverse removal procedures. Tighten all nuts and bolts after vehicle has been lowered to ground.

#### STABILIZER BAR

**Removal** — Raise and support rear of vehicle. Remove attaching nuts and bolts. Remove stabilizer bar and hardware.

**Inspection** — Inspect all components for wear or damage. Replace parts as necessary.

**Installation** — Reverse removal procedures. Tighten all nuts and bolts after vehicle has been lowered to ground.

### TIGHTENING SPECIFICATIONS

Application	Ft. Lbs. (N.m)
Lateral Rod-to-Mount	
GLC .....	47-59 (64-80)
626 .....	56-76 (76-103)
Shock Absorber-to-Mount .....	47-59 (64-80)
Shock Absorber Bracket-to-Body .....	34 (46)
Stabilizer Bar Mount-to-Axle .....	27-38 (37-52)
Stabilizer Bar Mount-to-Body .....	27-38 (37-52)
Upper & Lower Control Arm Bolts	
GLC .....	47-59 (64-80)
626 & RX7 .....	56-76 (76-103)
Watt Link Bracket-to-Axle .....	56-76 (76-103)
Watt Links-to-Brackets .....	47-59 (64-80)