

BMW

320i
528i
633CSi
733i

DESCRIPTION

Strut type suspension consisting of a vertically mounted strut assembly. Strut assembly is mounted to chassis frame at top by means of a thrust bearing. Lower end of strut assembly is mounted to ball joint which is bolted to lower control arm. Strut assembly connects to ball joint by means of a steering knuckle which is bolted to strut assembly and ball joint. Strut assembly consists of a shock absorber built into strut tube. A coil spring is mounted on outside of strut assembly. A stabilizer bar is mounted to front of axle carrier (crossmember) and is connected at ends to lower control arms. On all models except 320i, a strut rod is connected to lower control arm and axle carrier.

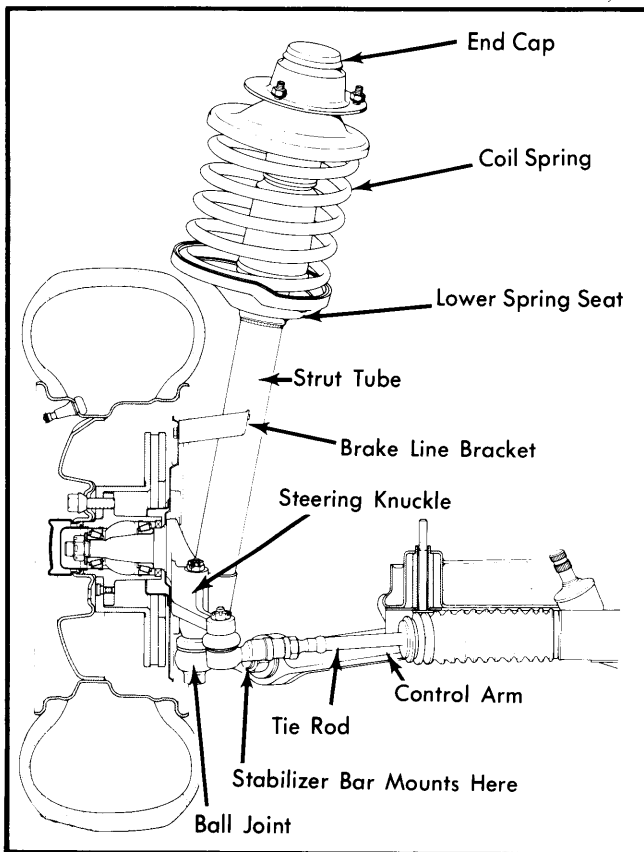

Fig. 1 BMW 320i Front Suspension Assembly

ADJUSTMENTS

WHEEL ALIGNMENT SPECIFICATIONS & PROCEDURES

See *Wheel Alignment Specifications and Procedures* in **WHEEL ALIGNMENT** Section.

WHEEL BEARING ADJUSTMENT

320i Models — While rotating wheel hub, tighten castle nut to 22-24 ft. lbs. (30-33 N•m), then rotate hub at least 2 more times. Loosen castle nut until bearing end play is noticed. Tighten castle nut to a maximum of about 24 INCH lbs. (3 N•m), then loosen to nearest hole and install cotter pin.

NOTE — After adjustment, slotted washer should move easily, without noticeable resistance.

528i, 633CSi & 733i Models — Tighten castle nut to 22-24 ft. lbs. (30-33 N•m) while continuously rotating wheel. Loosen castle nut until there is visible axial bearing play. Again rotate wheel and tighten nut, this time to 24 INCH lbs. (3 N•m). Insert cotter pin. Thrust washer should have movement with only slight resistance after adjustment.

BALL JOINT CHECKING

Axial movement of ball joint with pressure applied by leverage should be .055" (1.4 mm) or less. If play exceeds specifications replace control arm assembly.

REMOVAL & INSTALLATION

FRONT SUSPENSION ASSEMBLY

Removal — 1) Raise and support vehicle. Remove front wheels. Detach brake line mounting brackets from strut tube. If equipped with brake wear sensor, unplug connector and remove ground wire at caliper. On all models, remove calipers and suspend out of way (with hydraulic lines connected). On 320i, disconnect stabilizer bar at frame.

2) Disconnect steering shaft pinch bolt at universal joint. Index mark shaft and separate from "U" joint. Drain power steering

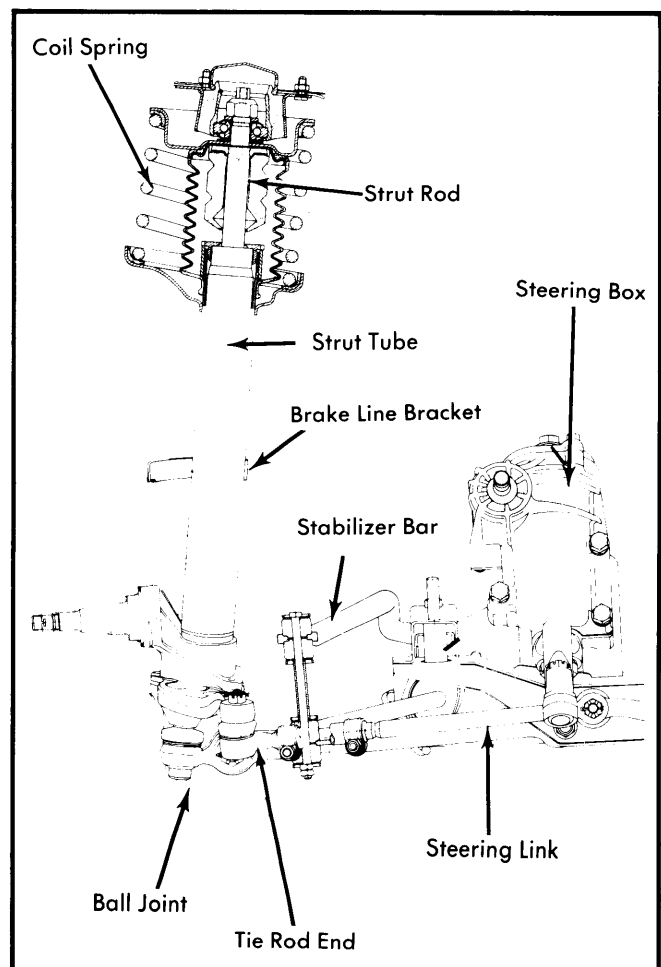

Fig. 2 BMW 528i, 633CSi and 733i Front Suspension

BMW (Cont.)

unit, detach power steering hoses and plug openings. Remove nuts from engine dampers, heat shields and engine mounts (as equipped). Remove clamps from automatic transmission cooling lines (if equipped).

3) Check along front axle for engine ground wire. If attached at this location, remove wire. Detach top strut-to-fender mountings. Using overhead hoist to support engine and a floor jack to support suspension, detach right end of front axle from frame member and lower suspension from vehicle.

Installation — To install reverse removal procedure and note the following: Make sure shoulder of engine mount engages properly in opening. Reconnect steering shaft while front wheels are pointing straight ahead. Ensure steering shaft index marks are aligned and that mounting screw engages safety groove. Check wheel alignment and bleed power steering unit, if equipped.

LOWER CONTROL ARM

Removal — **1)** Raise vehicle and remove front wheel. Disconnect stabilizer link or bar from control arm. If strut rod connects to control arm, remove from arm.

2) Detach inner end of control arm from axle carrier. On models held with castle nut only, remove castle nut and press control arm from steering knuckle. If held with safety wire, remove wire, then separate control arm and steering knuckle from shock absorber assembly.

3) Detach tie rod ball joint. Remove castle nut from steering knuckle arm (if not done so in previous step) and press control arm free.

Inspection — Check axial play of ball joint. If play exceeds .055" (1.4 mm), replace control arm assembly.

Installation — To install, reverse removal procedure, replacing all self-locking nuts.

STRUT TUBE ASSEMBLY

Removal — **1)** Raise front of vehicle and remove front wheel. Detach stabilizer bar from control arm. Detach brake line brackets from strut tube. Remove caliper from rotor and suspend out of way. If equipped, detach brake warning indicator wire from caliper.

2) Detach tie rod ball joint from steering knuckle arm. Remove lower strut mounting bolts. Remove 3 upper strut mounting bolts and remove strut tube assembly.

Disassembly — **1)** Place strut tube assembly in spring compressor. Slightly collapse spring. Remove end cap. Unscrew piston rod lock nut. Slowly release spring pressure and remove upper spring seat bearing and mounting hardware.

2) Remove auxiliary spring off piston rod. Remove shock absorber cap nut. Slide out shock absorber. Pour out used fluid.

Reassembly — **1)** Fill strut housing with 1-1.5 ounces of SAE 30 oil.

2) Fit shock absorber. Tighten cap nut. Slide auxiliary spring into place. Guide coil spring into lower spring seat. Set upper bearing mount (upper spring seat) on top of coil spring. Slide

piston rod through opening, after extending rod as far as possible. Attach compressor and collapse spring enough to install upper mounting nut.

Installation — To install, reverse removal procedure and tighten all nuts and bolts.

STABILIZER BAR

Removal — Raise and support vehicle. Remove front wheels for easier access. Detach stabilizer link or bar from control arms. Remove stabilizer bar brackets and take stabilizer bar from vehicle.

NOTE — Before installation, inspect bushings for excessive wear and replace as necessary.

Installation — To install, reverse removal procedure.

STRUT ROD

Removal (633CSi) — **1)** Raise vehicle and place on safety stands. Remove front wheels.

2) Separate stabilizer bar from control arm. Remove nut and thrust washer mounting strut rod to control arm.

3) Remove opposite end strut rod nut. Separate control arm from crossmember (axle carrier) and remove strut rod.

Installation — To install, reverse removal procedure and note: Convex side of thrust washer faces nut.

WHEEL BEARINGS

Removal — **1)** Raise vehicle and remove tire and wheel. Separate bracket from strut, remove caliper and wire out of way. Remove cotter pin and retaining nut. Remove rotor. Remove hex head retaining screw from rotor and separate rotor from wheel hub. (Multiple retaining screws used on 528i).

2) Lift out oil seal and bearings. Pull out races with tool (00 8 550). On all models except 528i, races may be driven out with drift at notches in wheel hub.

Installation — Press new races into hub. Pack new bearings with grease, fill hub cavity with grease and install bearings. Fill shaft seal with graphite grease and press in. Reverse removal procedures to complete installation.

NOTE — Always replace races with bearings and always replace bearings in sets.

TIGHTENING SPECIFICATIONS

Application	Ft. Lbs. (N•m)
Axle Carrier-to-Body	
320i	32-35 (44-48)
528i, 633CSik & 733i	54-60 (73-82)
Control Arm-to-Axle Carrier	59-66 (80-90)
Shock Absorber Cap Nut	87-101 (118-137)
Stabilizer Bar Brackets	34-37 (46-50)
Stabilizer Bar or Link-to-Control Arm	
320i	50-65 (68-88)
528i & 633CSi	16-17 (22-23)
733i	18-20 (25-27)
Tie Rod Castle Nut	25-29 (34-39)