

## TRIUMPH SPITFIRE

### DESCRIPTION

Semi-trailing arm, independent type suspension utilizing a transverse leaf spring. Strut rods are connected at front to chassis and at rear to axle bearing carrier. Transverse leaf spring is mounted in center to differential and at ends to mounts connected to bearing carrier. Hydraulic shock absorbers are mounted between bearing carrier at bottom and chassis at top.

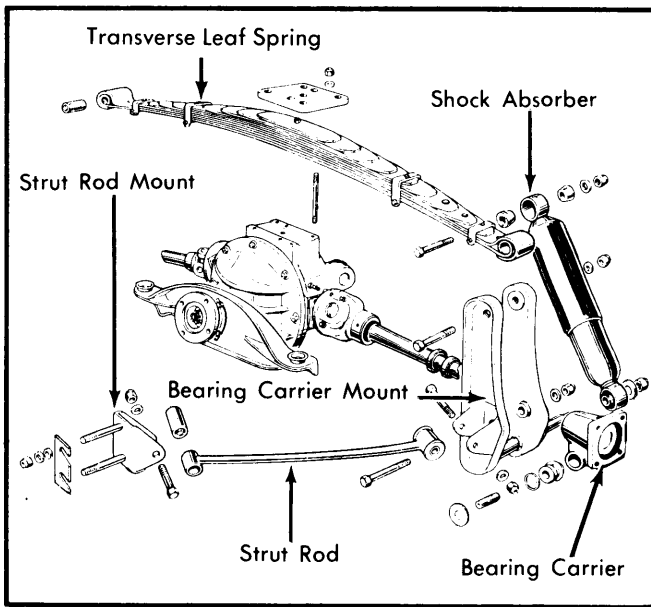

**Fig. 1 Exploded View of Rear Suspension Assembly**

### ADJUSTMENT

#### WHEEL ALIGNMENT SPECIFICATIONS & PROCEDURES

See *Wheel Alignment Specifications and Procedures* in **WHEEL ALIGNMENT** Section.

### REMOVAL & INSTALLATION

#### TRANSVERSE LEAF SPRING

**Removal** — Raise vehicle, position safety stands under chassis and remove both rear wheels. Remove bolts connecting transverse leaf spring to bearing carrier mount. Place a jack under lower shock absorber mount and disconnect lower shock absorber from mount on bearing carrier. From inside luggage compartment, remove plate covering spring mount on differential. Remove nuts and clamp plate from spring mount. Remove mounting studs from differential and pull spring out through side of fender well.

**Installation** — To install transverse leaf spring, reverse removal procedure. Spring is marked "FRONT" and must be installed correctly. Do not tighten spring-to-bearing carrier bolts until weight of vehicle is on rear wheels.

#### STRUT ROD

**Removal** — Raise vehicle, position safety stands under chassis, and remove wheels. Place a jack under lower shock absorber mount and raise jack until strut rod bolts can be removed easily. If shims are removed from strut rod mount on chassis, note number for installation reference.

**Installation** — To install strut rod, reverse removal procedure and note the following: Install same number of shims at front mount as removed and check rear wheel alignment.

#### BEARING CARRIER MOUNT

**Removal** — Raise vehicle, position safety stands under chassis and remove wheel and tire. Disconnect strut rod from bearing carrier mount. Remove pivot bolt securing mount to bearing carrier and remove mount.

**Installation** — To install bearing carrier mount, reverse removal procedure.

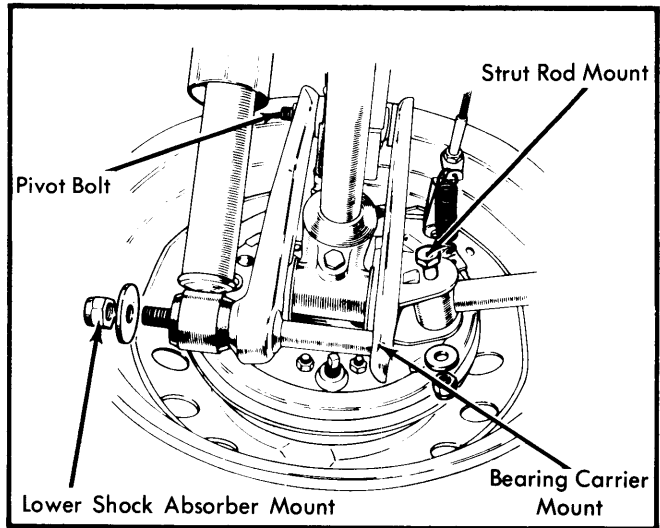

**Fig. 2 Components to Remove to Take Out Bearing Carrier Mount**

### TIGHTENING SPECIFICATIONS

Application	Ft. Lbs. (mkg)
Lower Shock Absorber Mount.....	28-38 (3.9-5.3)
Upper Shock Absorber Mount.....	38-48 (5.3-6.6)
Strut Rod Pivot Bolts.....	24-32 (3.3-4.4)
Strut Rod Bracket-to-Chassis.....	24-32 (3.3-4.4)
Mounts-to-Bearing Carrier.....	38-48 (5.3-6.6)
Transverse Spring Pivot Bolts.....	38-48 (5.3-6.6)