

## JAGUAR

XJ6

## DESCRIPTION

Independent, coil spring type suspension. Outer bearing carrier and hub assembly is supported by control arms at bottom and utilizes drive axles as upper support. Suspension is controlled by 2 coil spring/shock absorber assemblies mounted at each rear wheel. Movement of lower control arms is controlled by radius arms connected to control arms at rear and to chassis members at front.

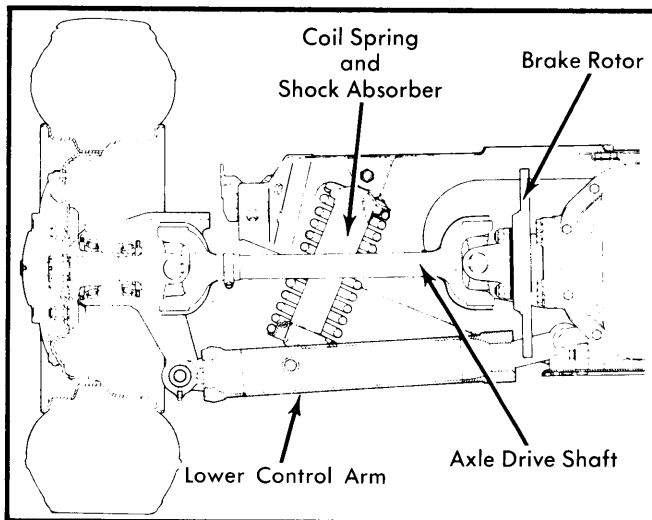

Fig. 1 Jaguar Rear Suspension Assembly

## ADJUSTMENTS

## WHEEL ALIGNMENT SPECIFICATIONS &amp; PROCEDURES

See *Wheel Alignment Specifications and Procedures* in *WHEEL ALIGNMENT* Section.

## REMOVAL &amp; INSTALLATION

## COIL SPRING &amp; SHOCK ABSORBER

**NOTE** — Rear springs can be removed with rear suspension installed in vehicle.

**Removal** — Raise vehicle and support at lift points with jack stands. Position floor jack under control arm. Remove nut and bolt mounting top of shock absorbers to the suspension assembly crossmember. Remove washers and nuts securing shock absorbers to lower mounting. Using a drift, remove mounting piece. Withdraw shock absorber and coil spring assembly. Using a spring compressor, collapse spring until collets and spring seat can be removed. Release pressure and separate shock absorber from spring.

**Installation** — To install spring and shock absorber assembly, reverse removal procedure and tighten all nuts and bolts.

## RADIUS ROD

**Removal** — 1) Raise and support vehicle on safety stands forward of radius rods. Remove tire and wheel. Remove bolt

and spring washer securing safety strap to body. Remove lock wire and bolt securing radius rod to body, then remove safety strap.

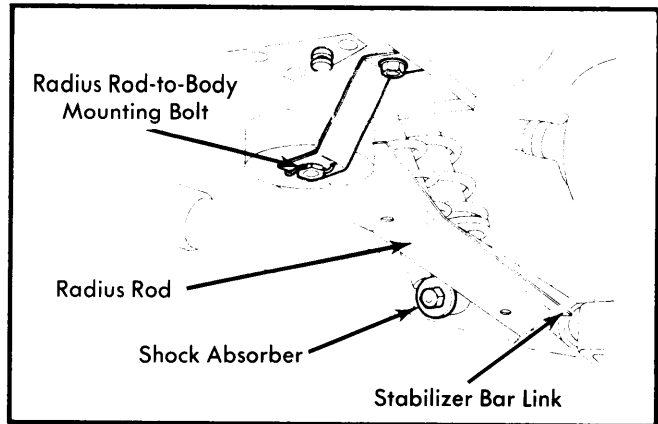

Fig. 2 Installed Position of Radius Rod

2) Remove forward lower shock absorber mounting pin. Using a punch, remove pin rearward. Bend tab washer and remove bolt mounting radius rod to control arm.

**Installation** — Replace any damaged radius rod bushings. When pressing bushings into radius rod, bushing should protrude from each side equal amounts. To install, reverse removal procedure.

## REAR SUSPENSION ASSEMBLY

**Removal** — 1) Raise and support vehicle forward of radius rods. Remove tires and wheels. Place floor jack (with adaptor to hold suspension assembly) under rear suspension.

2) Disconnect intermediate exhaust pipes at both ends and remove from vehicle. Support rear mufflers out of way. Disconnect radius rod-to-body mounting hardware.

3) Separate brake line union from body bracket. Disconnect brake lines at flexible hoses and plug openings. Disconnect propeller shaft at differential and lower out of way.

4) Release parking brake. Disconnect parking brake cable from junction at rear suspension assembly. Remove suspension mounting bracket nuts. Lower suspension assembly to ground and slide from vehicle.

**Installation** — Reverse removal steps and bleed brake system.

## LOWER CONTROL ARM

**Removal** — 1) Raise and support vehicle with stands placed ahead of radius rods. Remove tire and wheel.

2) Remove lock nut and drift out bearing carrier fulcrum shaft. Fit dummy shaft for support. Collect shims and oil seal retainers.

3) Lift bearing carrier up, clear of control arm. Keep carrier in position with heavy wire attached to crossmember. Separate radius rod from body.

## JAGUAR (Cont.)

4) Remove 14 bolts mounting support plate to crossmember and inner fulcrum brackets. Separate shock absorber at upper mount. Drift out pivot pin.

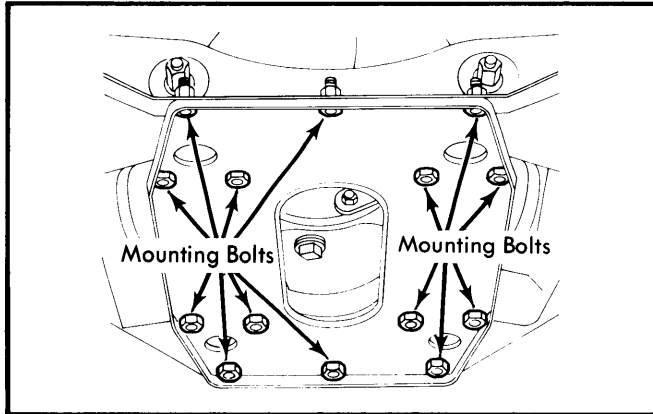

**Fig. 3 Bolts and Setscrews Mounting Support Plate to Crossmember and Inner Fulcrum Brackets**

5) Separate inner fulcrum from control arm. Guide out control arm and radius rod.

**Installation** - 1) Smear bearing cage with grease and force bearing into lower control arm. Marking cast on bearing faces out. Insert bearing tube for other end and force in opposite end bearing. Repeat procedure for other boss.

2) Assemble radius rod to control arm. Lightly coat thrust washers, new oil seals and oil seal retainers with grease. Fit assemblies into place on control arm.

3) Insert control arm to inner fulcrum mounting bracket. Make sure radius rod bracket faces toward front of suspension.

4) Insert dummy shaft from each end to keep bearings positioned then locate control arm in bracket. Slip in fulcrum shaft while pushing out dummy shaft. Install lock nut.

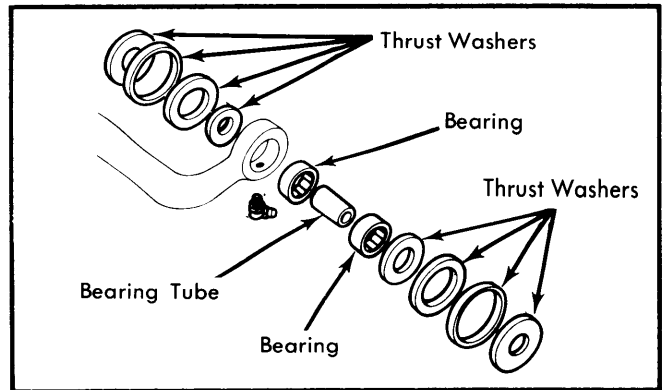

**Fig. 4 Fulcrum Boss Assembly**

5) To install remaining components, reverse removal procedure.

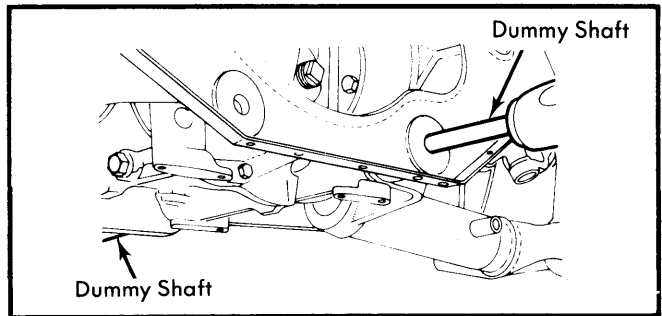

**Fig. 5 Locating Control Arm in Mounting Bracket with Dummy Shafts**

### TIGHTENING SPECIFICATIONS

Application	Ft. Lbs. (mkg)
Radius Rod-to-Control Arm .....	60-70 (8.3-9.7)
Radius Rod-to-Body .....	40-45 (5.5-6.2)
Shock Absorbers .....	32-36 (4.4-5.0)
Support Plate-to-Crossmember and Inner Fulcrum Mounting .....	14-18 (1.9-2.5)
Inner Fulcrum Shaft .....	45-50 (6.2-6.9)
Stabilizer Bar Bracket-to-Body .....	14-18 (1.9-2.5)