

Rear Suspension

AUDI

4000
5000

DESCRIPTION

Suspension on all Audi models consists of coil springs, shock absorbers, transverse rod and trailing arms. Some design differences occur between models.

On 5000 models, rear suspension arrangement is illustrated in Fig. 1. On these models, coil spring is mounted directly on rear axle and shock absorber is mounted separately. Transverse rod mounts behind axle beam. Top end of shock absorber is a stud type mount incorporating a rubber damper assembly.

On 4000 models, coil spring and shock absorber are combined into a single, strut type assembly. A transverse rod is also used and mounts diagonally in front of axle beam. See Fig. 2.

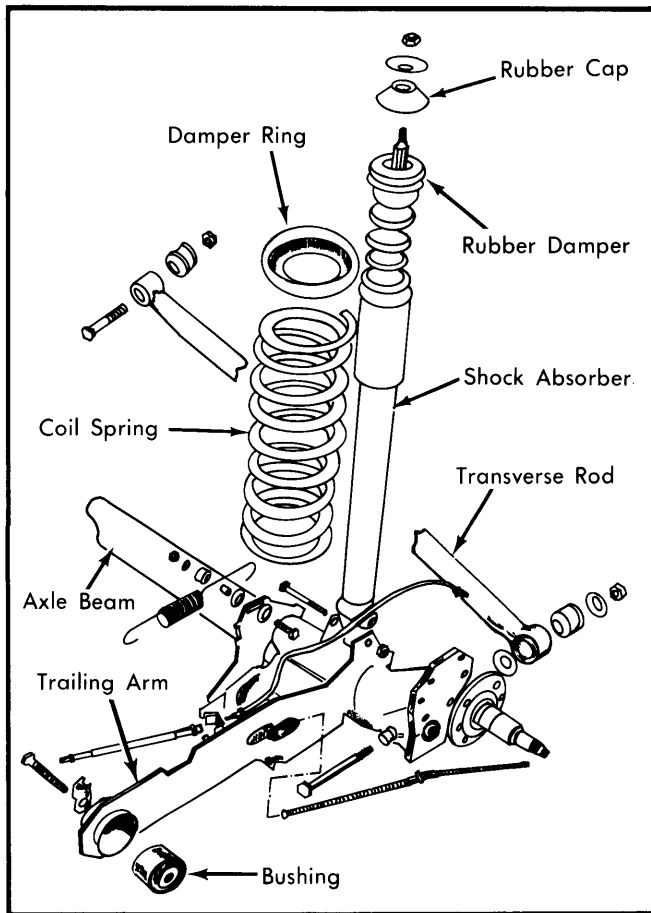

Fig. 1 Exploded View of Audi 5000 Rear Suspension

ADJUSTMENTS

WHEEL ALIGNMENT SPECIFICATIONS & PROCEDURES

See *Wheel Alignment Specifications and Procedures* in **WHEEL ALIGNMENT** Section.

WHEEL BEARING ADJUSTMENT

See *Wheel Bearing Adjustment* in **WHEEL ALIGNMENT** Section.

REMOVAL & INSTALLATION

REAR AXLE ASSEMBLY

Removal (4000) – 1) Raise and support vehicle and remove rear wheels. Unhook muffler hangers, lower muffler with tailpipe and secure.

2) Remove nut on parking brake linkage equalizer bar. Pry cable sleeves out of brackets and remove parking brake cables from their brackets.

3) Detach brake hoses and plug lines. Remove nuts from trailing arm mounting bolts, leaving bolts in place. Disconnect spring from brake pressure regulator.

4) Remove transverse rod mounting bolt, suspension strut mounting bolts, and trailing arm mounting bolts. Remove rear axle assembly while guiding parking brake cable over tailpipe and muffler.

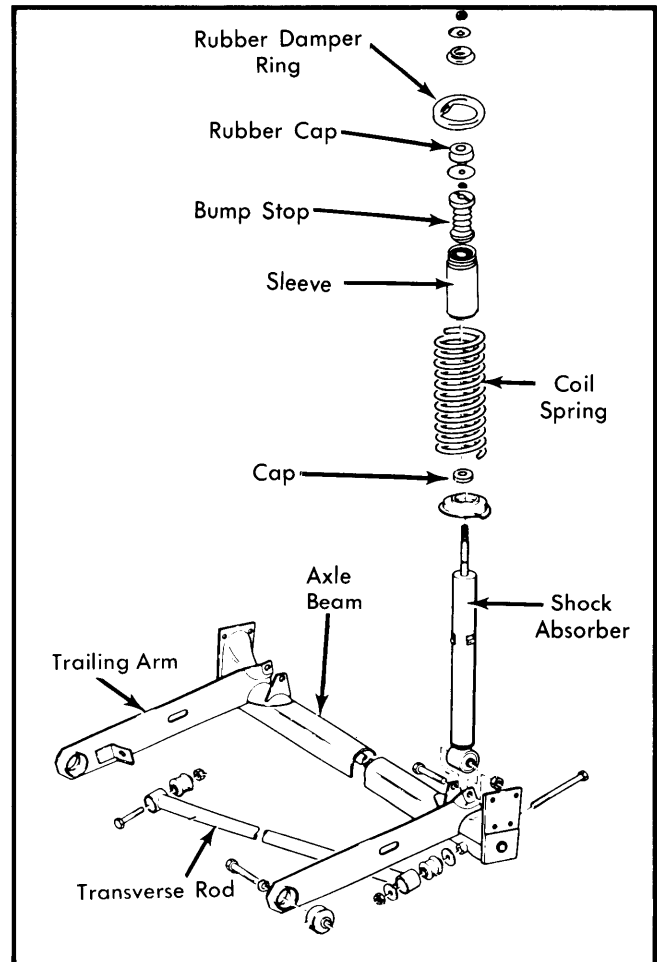

Fig. 2 Exploded View of Audi 4000 Rear Suspension

AUDI (Cont.)

Bushing Replacement (4000) – Place trailing arm in press and force bushing from arm. Reverse process to install new bushing. Make sure bushing slots are positioned horizontally in trailing arm.

Installation (4000) – 1) Raise and support vehicle. Place rear axle in position. Install both trailing arm bolts and hand tighten. Install rear wheels, lower vehicle and tighten trailing arm bolts with wheels on ground.

2) Install transverse rod, brake hoses, and spring for pressure regulator. Bleed brakes, attach parking brake cable and adjust.

Removal (5000) – 1) Loosen, but do not remove wheel bolts. Raise and support vehicle. Remove bolt from transverse rod at axle mounting. Detach right brake hose at coupling with steel tubing. Plug openings.

2) Detach brake pressure regulator spring (hooked to lower mounting bolt of shock absorber). Detach left brake hose at connection with tubing and plug openings.

3) Remove right fuel tank retaining strap. Remove parking brake cable from guide on fuel tank. Loosen left side parking brake cable bolt. Loosen parking brake adjusting nut and disconnect parking brake cable.

4) Remove rear mounting for exhaust system. Lower vehicle to ground. Remove both shock absorber top nuts. Using frame jack, raise vehicle slowly until coil spring can be removed from axle mountings. Remove rear wheels.

5) Remove trailing arm mounting bolts, with rear axle suitably supported on a jack. While slowly lowering axle assembly from vehicle, guide parking brake cable over exhaust pipe.

Bushing Replacement (5000) – Place trailing arm in press and force bushing from arm. Reverse process to install new bushing. Align cutouts with center axis.

Installation (5000) – 1) Raise vehicle and position rear axle in vehicle. Install and lightly tighten trailing arm mounting bolts. Install both rear wheels and lower vehicle to ground.

2) Position rubber damper rings on coil springs, jack up vehicle body, position springs and slowly lower body to hold springs (3 persons may be required to perform this step).

3) Tighten shock absorber top mounting nuts. Raise vehicle and check position of coil springs. If necessary, turn springs in mounting to correct their positions.

4) With vehicle resting on ground, tighten trailing arm bolts. Install transverse rod, brake hoses, spring for brake pressure regulator and fuel tank retaining strap.

5) Bleed brake system, attach and adjust parking brake cable.

TRANSVERSE ROD

Removal (All Models) – Raise and support vehicle. Remove nuts from transverse rod bolts and tap bolts out of holes. Inspect bushings and sleeves for wear and replace if necessary.

Installation (All Models) – To install, reverse removal procedure.

SHOCK ABSORBERS

NOTE – Remove and install shock absorbers one at a time. Do not allow rear axle to hang from body mounts only.

Removal (4000) – Loosen trunk sheet metal trim and remove shock absorber top protective cap. Remove upper mounting nut. Raise vehicle, remove lower mounting bolt and remove shock absorber.

Removal (5000) – Remove top shock absorber mounting. Remove lower mounting and shock.

Installation (All Models) – To install, reverse removal procedure. On 4000 models, be sure top protection cap is properly installed.

TIGHTENING SPECIFICATIONS

Application	Ft. Lbs. (mkg)
Shock Absorbers	
4000	
Upper	14 (2.0)
Lower	43 (6.0)
5000	
Upper	14 (2.0)
Lower	40 (5.5)
Transverse Rod	
4000	51 (7.0)
5000	65 (9.0)
Trailing Arm	
4000	72 (10.0)
5000	69 (9.5)