

PORSCHE 924

DESCRIPTION

Vehicle uses independent strut type front suspension. Lower control arms mount with a ball joint to steering knuckle. Back branch of control arm mounts to frame with "U" clamp around control arm pivot shaft. Front branch attaches to frame with bushings and pivot bolt. Strut assembly mounts at top to body with 3 nuts and at bottom to steering knuckle with 2 bolts. Tie rod mounts to steering knuckle with ball joint.

ADJUSTMENTS

WHEEL ALIGNMENT SPECIFICATIONS & PROCEDURES

See *Wheel Alignment Specifications and Procedures* in **WHEEL ALIGNMENT** Section.

WHEEL BEARING ADJUSTMENT

See *Wheel Bearing Adjustment* in **WHEEL ALIGNMENT** Section.

BALL JOINT CHECKING

See *Ball Joint Checking* in **WHEEL ALIGNMENT** Section.

REMOVAL & INSTALLATION

STRUT ASSEMBLY

Removal — 1) Raise vehicle so front suspension and front wheels are not supported.

2) Remove bolts mounting suspension strut to steering knuckle. Note that top bolt is one used to adjust front wheel camber.

3) Detach brake line from brake line bracket on strut. Remove brake caliper assembly and suspend out of way. Pry strut off of steering knuckle.

4) Support front suspension. Work inside engine compartment and remove strut upper mounting nuts. Guide assembly out of vehicle.

Disassembly — 1) Fit strut to spring compressor. Slightly collapse coil spring. Remove shock absorber piston rod nut. Take off the following:

- Stop
- Seal
- Bearing flange
- Bearing
- Spring seat

2) Slowly release spring pressure, remove coil spring. Lift off rubber buffer and protective sleeve. Hold shock absorber upright and work piston rod through entire stroke several different times. Equal pressure must be felt in both directions. Remove cap nut and take out shock absorber.

Reassembly — 1) Place shock absorber in strut tube and fit cap nut. Slide on protective sleeve and buffer. Position coil spring into lower seat.

NOTE — If new coil spring is being installed, ensure that paint stripe color code matches that of spring on opposite side.

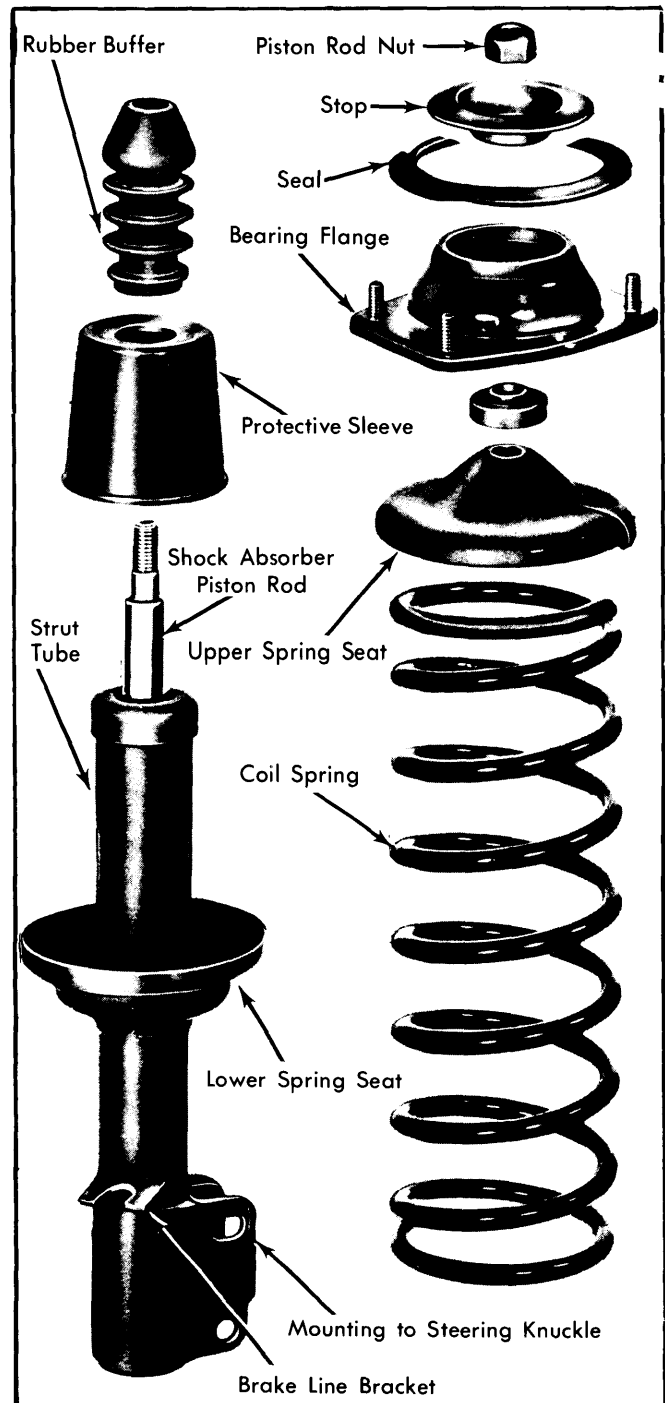

Fig. 1 Exploded View of Strut Assembly

2) Fit coil spring to compressor and collapse coil enough to allow piston rod threads to be exposed after upper mounting hardware is fitted. Tighten piston rod lock nut. Release spring pressure.

Installation — To install, reverse removal procedure and check front wheel alignment.

Front Suspension

PORSCHE 924 (Cont.)

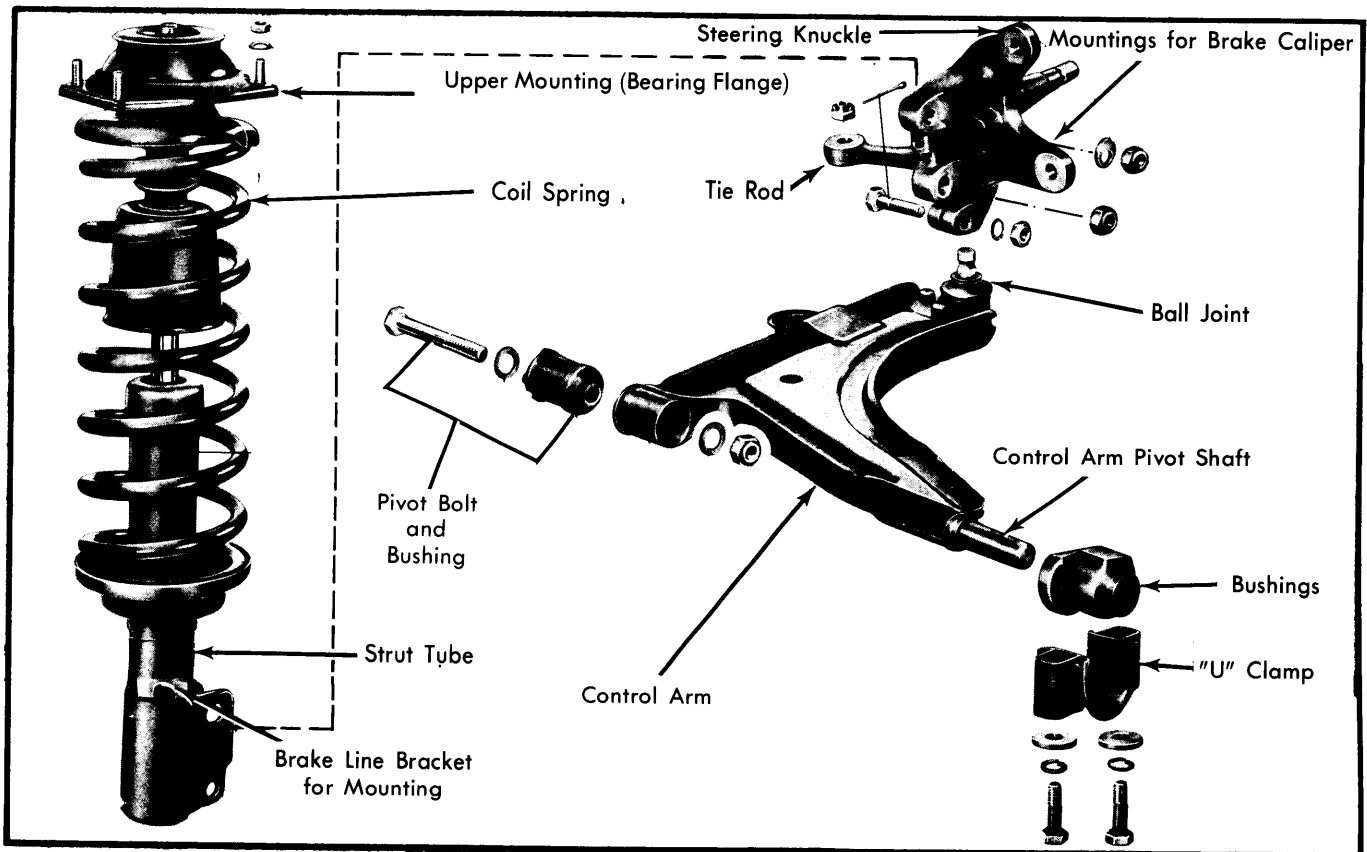

Fig. 2 Exploded View of 924 Front Suspension

CONTROL ARM & BALL JOINT

NOTE — If there is enough access room to work, lower control arm does not have to be removed to replace ball joint.

Removal — 1) Raise vehicle and support so suspension is free. Remove pinch bolt mounting ball joint in bottom of steering knuckle. Pull ball joint out of steering knuckle.

2) If control arm is not being removed, drill through ball joint rivets with about 15/64" (6 mm) bit. Chisel off rivet heads. Fit new ball joint into slot on control arm and install bolts so heads are on top.

3) If control arm is being removed, take out mounting pivot bolt and "U" clamp housing inner pivot pin. Slide out control arm. For ball joint replacement, refer to step 2).

Inspection — Check control arm bushings. If bushings are bad they can be replaced. Press out worn bushings. Select new bushing and press into position. Make sure new bushings do not twist when seating into position.

Installation — To install, reverse removal procedure.

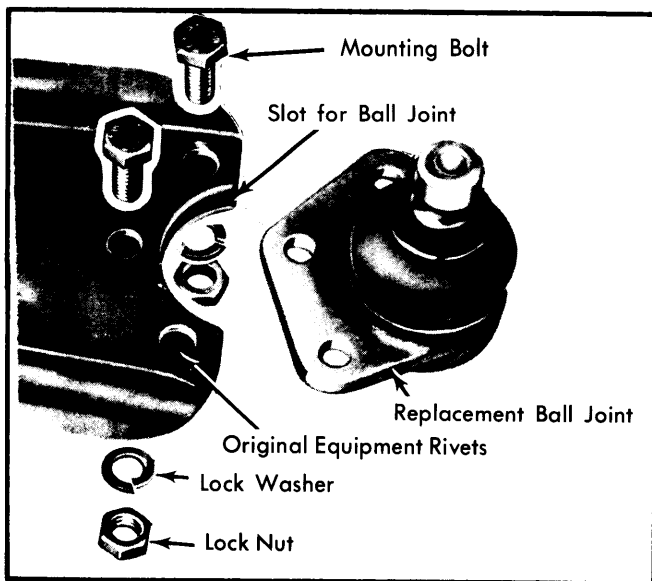

Fig. 3 Ball Joint Location in Control Arm

TIGHTENING SPECIFICATIONS

Application	Ft. Lbs. (mkg)
Control Arm-to-Crossmember	40-54 (5.5-7.5)
"U" Clamp Bolts.....	30 (4.2)
Tie Rod Castle Nut	22-36 (3.0-5.0)
Strut Piston Rod Nut	56-58 (7.7-8.0)
Strut-to-Steering Knuckle	51-72 (7.0-10.0)
Upper Strut Mount.....	15-21 (2.1-2.9)
Ball Joint-to-Control Arm (Replacement).....	18 (2.5)
Ball Joint Pinch Bolt.....	36-43 (5.0-6.0)