

JAGUAR

XJ6

DESCRIPTION

Suspension consists of upper and lower control arms, double acting hydraulic shock absorbers, coil springs, stabilizer bar and steering knuckles. The upper control arms are mounted inboard to fulcrum shafts and are mounted outboard to steering knuckles by upper ball joints. Lower control arms are mounted inboard to crossmember and outboard to steering knuckles by lower ball joints. Coil springs are mounted between lower control arms and crossmember. Shock absorbers are attached at the bottom to lower control arms and at the top to body. Stabilizer bar is attached to lower control arms and crossmember.

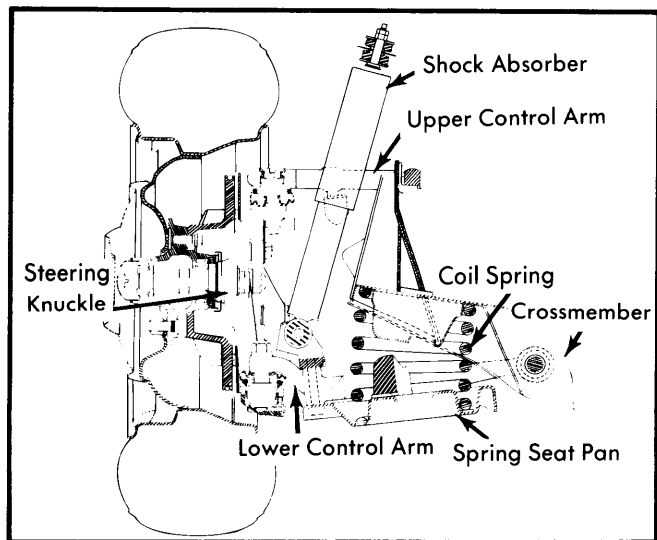

Fig. 1 Sectional View of Front Suspension Assembly

ADJUSTMENT

WHEEL ALIGNMENT SPECIFICATIONS & PROCEDURES

See *Wheel Alignment Specifications and Procedures* in **WHEEL ALIGNMENT** Section.

WHEEL BEARING ADJUSTMENT

See *Wheel Bearing Adjustment* in **WHEEL ALIGNMENT** Section.

BALL JOINT CHECKING

See *Ball Joint Checking* in **WHEEL ALIGNMENT** Section.

FRONT SUSPENSION ASSEMBLY

Removal — 1) Disconnect battery and remove air cleaners. Disconnect the upper end of shock absorber. Drain and discard power steering fluid. Disconnect and plug power steering inlet and outlet hoses.

2) Remove nuts securing engine mounts to brackets on frame crossmember. Disconnect rear crossmember mountings, then separate stabilizer bar from link. Turn steering column until pinch bolt holding lower "U" joint to pinion shaft is accessible. Remove pinch bolt.

3) Return steering to straight-ahead position. Set ignition to "LOCK" and remove key. Separate lower steering column from upper "U" joint, then from pinion shaft.

4) Raise and support vehicle. Remove front wheels. Disconnect brake hoses and lines. Detach ground strap from engine. Remove suspension mounting bolts. Collect and note location of all washers, spacers and bushings. Remove suspension assembly from vehicle.

Installation — To install, reverse removal procedure and note the following:

- Be sure brake lines and hoses are properly routed without bends or kinks.
- It may be helpful to remove protective heat shield covering boot on rack and pinion steering prior to positioning suspension into place.
- Be sure power steering reservoir is full before starting engine after installation.
- If additional information is required on steering column installation, see appropriate article in **STEERING** section of this manual.
- Bleed brake system.

SHOCK ABSORBERS

Removal — Detach upper shock absorber mounting. Raise and support vehicle. Remove front wheel if necessary for access to lower mounting. Remove lower shock absorber mounting and remove from vehicle.

Installation — To install, reverse removal procedure.

COIL SPRINGS

Removal — Raise and support vehicle, then remove tire and wheel. Fit a spring compressor (JD-6D & adaptor JD-6D-1) and collapse spring coil enough to allow load on pan seat to be relieved. Remove hardware mounting spring pan to lower control arm. Slightly loosen spring compressor and remove assembly complete.

NOTE — Be sure to note number and location of any packing shims.

Installation — To install coil spring, reverse removal procedure noting the following: Floor jack can be placed under lower ball joint to aid in aligning spring pan bolt. A maximum of three packers may be placed in spring pan and no more than two can be fitted on crossmember.

LOWER CONTROL ARM

Removal — 1) Remove complete suspension assembly as described in this article.

2) With assembly on bench, detach tie rod ball joints from steering knuckle, then detach and remove steering rack from crossmember. Use spring compressor to remove coil spring. Separate upper ball joint, noting location of all caster shims. Detach lower ball joint.

3) Remove stabilizer bar support bracket and shock absorber lower mounting. Remove cotter pin and pivot shaft nut. Drive pivot shaft from crossmember and collect spacers. Remove lower control arm.

Installation — To install, reverse removal procedure. Do not tighten pivot shaft nut until vehicle is resting on ground at full curb weight.

JAGUAR (Cont.)

UPPER CONTROL ARM

Removal – 1) Raise and support vehicle. Remove front wheel. Detach upper ball joint from control arm. Note number of all caster adjusting shims present.

2) Wire steering knuckle to coil spring and remove bolts holding upper control arm pivot shaft to vehicle. Note number and location of all camber adjusting shims. Remove control arm from vehicle.

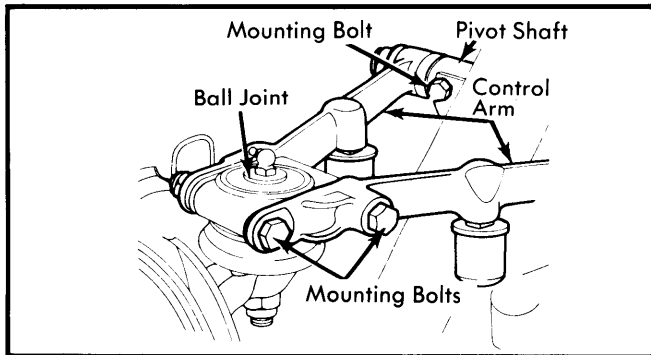

Fig. 2 Upper Control Arm Mounting Points

Installation – To install upper control arm, reverse removal procedure and tighten all nuts and bolts. Recheck wheel alignment.

STABILIZER BAR

Removal – Raise and support vehicle. Remove front wheels. Detach both ends of stabilizer bar from mounting links. Remove both mounting brackets from frame. Remove all mounting bushings from bar. Detach 1 tie rod end from steering knuckle and maneuver stabilizer from vehicle.

Installation – To install, reverse removal procedure, fully tightening stabilizer bar-to-link nuts after vehicle is resting on ground.

LOWER BALL JOINT

Removal – 1) Raise front of vehicle and place on safety stands. Remove wheel. Disconnect brake line from caliper and plug openings. Disconnect tie rod from steering arm. Twist stub axle carrier to gain access to bolts securing upper ball joint to control arm, then remove bolts. Note position and number of shims.

2) Remove nut mounting lower ball joint to control arm. Use tool JD 24 (or equivalent) to separate ball joint from control arm, then maneuver assembly from vehicle.

Disassembly & Reassembly – 1) Pry back tab washers and remove four screws keeping ball pin cap. Lift out ball pin. Release clip and remove upper socket from stub axle.

2) Clean all components and inspect for excessive wear or damage.

3) Install new upper socket to stub axle. Fit lip of boot clip in recess in socket. Lip **MUST** be near lower face of clip. Install new boot to clip and attach with plastic retaining ring. Grease new ball pin and put into position.

4) Put ball pin cap into vise and cut out lower socket. Clean shavings and fit new socket. Refit shims and replace ball cap.

Fit four setscrews with lock tabs and tighten, continually checking ball joint movement.

5) If ball pin is loose in socket, remove shims. If pin is excessively tight, add shims until movement is correct. Movement should be slightly stiff.

Installation – Insert ball joint in lower control arm and tighten lock nut. Align stub axle with upper control arm and insert bolts (bolt heads **MUST** face front). Make sure packing pieces and shims are properly installed. Reconnect tie rod. Attach brake lines and bleed brakes. Check camber and caster angles.

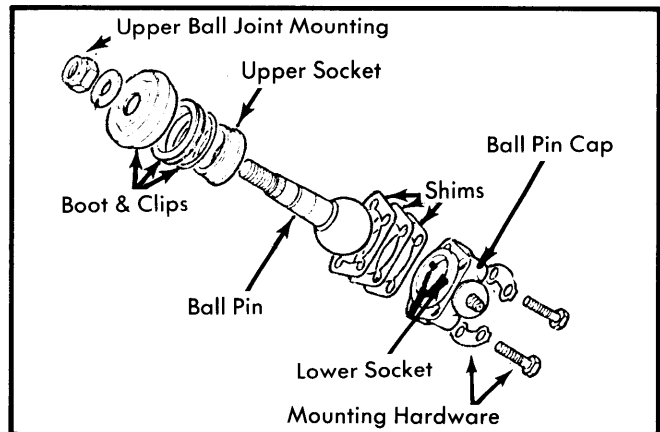

Fig. 3 Exploded View of Lower Ball Joint

UPPER BALL JOINT

NOTE – Upper control arm ball joint cannot be overhauled. If ball joint is excessively worn, assembly must be replaced.

Removal – 1) Raise vehicle and place on safety stands. Remove wheel. Twist steering to full lock position. Wire stub axle to crossmember to prevent tension on brake hose when ball joint is separated.

2) Remove bolt mounting upper ball joint to control arm. Note number of shims and position of packing pieces. Remove ball joint lock nut and separate ball joint from control arm. Maneuver assembly from vehicle. Withdraw ball joint from stub axle.

Installation – Apply grease to replacement ball joint and place in position in stub axle. Hold ball joint against taper fit washer and tighten retaining nut. Refit upper control arm mounting bolts (bolt heads must face forward) and caster shims. Check camber and caster angles.

TIGHTENING SPECIFICATIONS

Application	Ft. Lbs. (mkg)
Upper Pivot Shaft-to-Crossmember	49-55 (6.8-7.6)
Upper Ball Joint-to-Arm	26-32 (3.6-4.4)
Pivot Shaft-to-Upper Arm	45-55 (6.3-7.6)
Pivot Shaft-to-Lower Arm	32-50 (4.4-6.9)
Upper Shock Absorber	27-32 (3.8-4.4)
Lower Shock Absorber	32-36 (4.4-5.0)
Spring Pan	27-32 (3.8-4.4)
Stabilizer-to-Link	14-18 (2.0-2.5)
Tie Rod Nut	35-50 (4.8-6.9)