

Front Suspension

FIAT BRAVA

DESCRIPTION

Strut type front suspension consisting of a vertically mounted strut assembly. Strut assembly is mounted to body at the top by means of a rubber mount and lower end of strut is connected to steering knuckle. Strut assembly consists of hydraulic shock absorber with a coil spring mounted over outside. Lower control arm is connected to steering knuckle through ball joint and to front crossmember. A stabilizer bar is mounted to lower control arm and to frame.

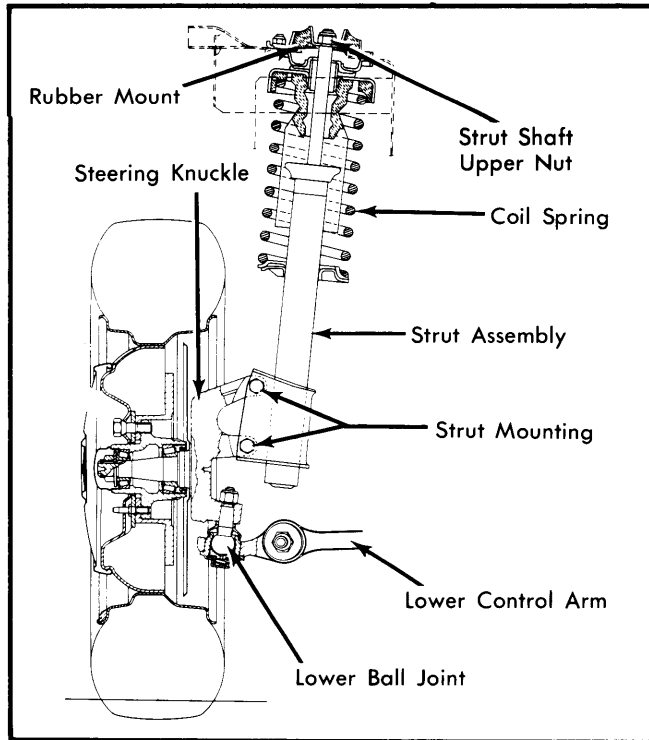

Fig. 1 Fiat Brava Front Suspension Assembly

ADJUSTMENTS

WHEEL ALIGNMENT SPECIFICATIONS & PROCEDURES

See *Wheel Alignment Specifications and Procedures* in **WHEEL ALIGNMENT** Section.

WHEEL BEARING ADJUSTMENT

See *Wheel Bearing Adjustment* in **WHEEL ALIGNMENT** Section.

BALL JOINT CHECKING

See *Ball Joint Checking* in **WHEEL ALIGNMENT** Section.

REMOVAL & INSTALLATION

FRONT SUSPENSION ASSEMBLY

Removal – 1) With vehicle on ground, remove upper nut and washer from strut shaft. Remove the 3 rubber mount nuts and washers. Remove rubber mount assembly. Install and tighten retaining tool (A74375) on strut shaft. Remove the 2 nuts and washers retaining strut to body.

2) Jack up vehicle and remove wheel. Disconnect brake hose from tube at clip on fenderwell. Disconnect tie rod from steering knuckle.

3) Position a jack under suspension assembly. Remove nut, washer and rubber bushing from end of sway bar. Remove nut, washer and bolt from control arm at frame. Remove arm from bracket. Push arm to rear to remove from sway bar end. Carefully lower suspension from vehicle.

Disassembly and Reassembly – 1) Disconnect control arm by removing ball joint stud nut and separating ball joint from steering knuckle. Remove strut assembly by removing nuts and bolts attaching assembly to steering knuckle.

2) Remove coil spring by using a coil spring compressor and removing retaining tool from strut shaft. Reassemble in reverse order of disassembly.

Installation – To install, reverse removal procedure and note the following: Lower vehicle to ground before removing retaining tool from strut shaft and installing rubber mount assembly.

CROSSMEMBER

Removal – 1) Install engine support. On models with manual steering, remove 4 bolts securing mounts for steering box to crossmember. On models with power steering, remove bolt holding left steering box mount to crossmember. Remove 2 bolts holding right steering box mount to crossmember.

2) On all models, remove battery cable from clips on crossmember. On models with power steering, remove 2 screws holding hydraulic line to crossmember.

3) On all models, remove 2 nuts holding crossmember to engine mounts. Remove 2 nuts and bolts holding lower support arms to crossmember. Remove 4 bolts and washers holding crossmember to frame. Remove crossmember.

Installation – To install, reverse removal procedure.

STRUT ASSEMBLY

Removal – With vehicle on ground, remove upper nut and washer from strut shaft. Remove the 3 rubber mount nuts and washers. Remove the rubber mount assembly. Install and tighten retaining tool (A74375) on strut shaft. Remove the 2 nuts and washers retaining strut to body. Remove 2 strut-to-knuckle bolts and remove strut.

NOTE – To remove coil spring from strut, see *Disassembly and Reassembly* under *Front Suspension Assembly*.

Installation – To install, reverse removal procedure and note the following: Lower vehicle to ground before removing retaining tool from strut shaft and installing rubber mount assembly.

TIGHTENING SPECIFICATIONS

Application	Ft. Lbs.(mkg)
Ball Joint-to-Steering Knuckle	58 (8)
Control Arm-to-Crossmember	65 (9)
Strut Assembly-to-Knuckle	36 (5)
Strut Assembly-to-Upper Mount	43 (6)
Strut Upper Mount-to-Body	18 (2.5)
Stabilizer Bar-to-Crossmember	65 (9)
Stabilizer Bar-to-Control Arm	43 (6)
Crossmember-to-Body	65 (9)